

Beware of duplicate interview question books in market with same name. Ask for interview question books only by Shivprasad Koirala from BPB publications.

How to buy the book

BPB has done a great job of making this book reach to places where i can hardly imagine. But just incase its not near to your place mail bpb@bol.net.in.

If you are from India you can contact one of the shops below:-

MUMBAI-22078296/97/022-22070989

KOLKATA-22826518/19

HYDERABAD-24756967,24756400

BANGALORE-25587923,25584641

AHMEDABAD-26421611

BHATINA(PUNJAB)-2237387,

CHENNAI-28410796,28550491

DELHI/NEW DELHI-23254990/91,23325760,26415092,24691288

Pakistan

M/s. Vanguard Books P Ltd, 45 The Mall, Lahore, Pakistan (Tel: 0092-42-7235767, 7243783 and 7243779 and Fax: 7245097)

E-mail: vbl@brain.net.pk

If you are not from india or pakistan :-

Ray McLennan, director,Motilal (UK) Books of India,367 High Street.

London Colney,

St.Albans, Hertfordshire,AL2 1EA, U.K.

Tel. +44 (0)1727 761 677,Fax.+44 (0)1727 761

357,info@mlbduk.com,www.mlbduk.com

Want to buy from online :-

.NET Interview Questions From Prakash books

<http://www.prakashbooks.com/details.php?id=17875&c=Computer Books>

If you want to buy from Amazon

<http://www.amazon.co.uk/exec/obidos/ASIN/8183330770/qid%3D1139594062/026-8105897-7667603>

SQL Server Interview Questions From Prakash books

<http://www.prakashbooks.com/details.php?id=19008&c=Computer Books>

If you want to buy from Amazon

<http://www.amazon.co.uk/exec/obidos/ASIN/8183331033/qid%3D1136610981/026-1344994-2263615#product-details>

If you want to purchase the book directly through BPB Publication's delhi , India :-

bpb@bol.net or bpb@vsnl.com

Titles written by Shivprasad Koirala

- .NET Interview questions
- SQL Server Interview questions
- Java Interview questions
- C# and ASP.NET Projects
- How to prepare Software quotations
- Excel for office people.
- Software Testing Interview questions
- Hacking for beginners

Mail bpb@bol.net.in for any of my titles above,.

From the Author

First thing thanks to all those who have sent me complaints and also appreciation for what ever titles i have written till today. But interview question series is very near to my heart as i can understand the pain of searching a job. Thanks to my publishers (BPB) , readers and reviewers to always excuse all my stupid things which i always do.

So why is this PDF free ?. Well i always wanted to distribute things for free specially when its a interview question book which can fetch a job for a developer. But i am also bounded with publishers rules and regulations. And why not they have a whole team of editor, printing guys, designers, distributors, shopkeepers and including me. But again the other aspect, readers should know of what they are buying , the quality and is it really useful to buy this book. So here are sample free questions which i am giving out free to the readers to see the worth of the book.

I can be contacted at shiv_koirala@yahoo.com its bit difficult to answer all answers but as i get time i do it.

We have recently started a career counselling drive absolutely free for new comers and experienced guys. So i have enlisted the following guys on the panel. Thanks to all these guys to accept the panel job of consulting. Feel free to shoot them questions just put a title in the mail saying “Question about Career”. I have always turned up to them when i had some serious career decision to take.

Shivprasad Koirala :- Not a great guy but as i have done the complete book i have to take up one of the positions. You can contact me at shiv_koirala@yahoo.com for technical career aspect.

Tapan Das :- If you think you are aiming at becoming a project manager he is the right person to consult. He can answer all your questions regarding how to groom your career as a project manager tapand@vsnl.com.

Kapil Siddharth :- If you are thinking to grow as architect in a company then he is a guy. When it comes to role model as architect i rate this guy at the top. You can contact him at kapilsiddharth@hotmail.com

Second if you think you can help the developers mail me at shiv_koirala@yahoo.com and if i find you fitting in the panel i will display your mail address. Please note there are no financial rewards as such but i am sure you will be proud of the work you are doing and whos knows what can come up.

Lets make Software Industry a better place to work Happy Job Hunting and Best of Luck

.NET Interview Questions

Third Edition

(Including .NET 3.0 , AJAX/ATLAS , Vista series (WCF / WPF / WWF) ,UML,Architecture,Project Management ,SQL Server , Sample project and General Interview Questions)

Happy job hunting.....

Contents

Introduction	18
Software Company hierarchy	22
Resume Preparation Guidelines	23
Salary Negotiation	26
Points to remember	28
Interview rating Sheet.....	30
1. Basic .NET Framework	33
What is a IL?	33
<i>Twist :- What is MSIL or CIL , What is JIT?</i>	33
What is a CLR?	33
What is a CTS?	33
What is a CLS(Common Language Specification)?	34
What is a Managed Code?	34
What is a Assembly?	34
What are the different types of Assembly?	35
What is NameSpace?	35
What is Difference between NameSpace and Assembly?	35
If you want to view a Assembly how do you go about it ?	35
<i>Twist : What is ILDASM ?</i>	35
What is Manifest?	37
Where is version information stored of an assembly ?	38
Is versioning applicable to private assemblies?	38
What is GAC ?	38
<i>Twist :- What are situations when you register .NET assembly in GAC ?</i>	38
What is the concept of strong names ?	38
<i>Twist :- How do we generate strong names ?</i>	38
<i>Twist :- What is use the of SN.EXE ?</i>	38
<i>Twist :- How do we apply strong names to assembly?</i>	38
<i>Twist :- How do you sign an assembly?</i>	38
How to add and remove an assembly from GAC?	43
What is Delay signing ?	44
What is garbage collection?	45
Can we force garbage collector to run ?	45
What is reflection?	45
What are different types of JIT ?	46
What are Value types and Reference types ?	47
What is concept of Boxing and Unboxing ?	47
What is the difference between VB.NET and C# ?	48
What is the difference between System exceptions and Application exceptions?	49
What is CODE Access security?	50
What is a satellite assembly?	50
How to prevent my .NET DLL to be decompiled?	50
What is the difference between Convert.ToString and .toString() method ?	50
What is Native Image Generator (Ngen.exe)?	51

If we have two version of same assembly in GAC how do we make a choice ?	52
What is CodeDom?	60
2..NET Interoperability	63
How can we use COM Components in .NET?	63
<i>Twist : What is RCW ?</i>	<i>63</i>
Once I have developed the COM wrapper do I have to still register the COM in registry?	64
How can we use .NET components in COM?	64
<i>Twist :- What is CCW (COM callable wrapper) ?</i>	<i>64</i>
<i>Twist :- How do we ensure that .NET components is compatible with COM ?</i>	<i>64</i>
How can we make Windows API calls in .NET?	67
When we use windows API in .NET is it managed or unmanaged code ?	69
What is COM ?	69
What is Reference counting in COM ?	69
Can you describe IUNKNOWN interface in short ?	69
Can you explain what is DCOM ?	70
How do we create DCOM object in VB6?	71
How to implement DTC in .NET ?	71
How many types of Transactions are there in COM + .NET ?	73
How do you do object pooling in .NET ?	74
What are types of compatibility in VB6?	75
What is equivalent for regsvr32 exe in .NET ?	76
3. Threading	77
What is Multi-tasking ?	77
What is Multi-threading ?	77
What is a Thread ?	77
Did VB6 support multi-threading ?	77
Can we have multiple threads in one App domain ?	77
Which namespace has threading ?	77
Can you explain in brief how can we implement threading ?	77
How can we change priority and what the levels of priority are provided by .NET ?	78
What does AddressOf operator do in background ?	79
How can you reference current thread of the method ?	79
What's Thread.Sleep() in threading ?	79
How can we make a thread sleep for infinite period ?	79
What is Suspend and Resume in Threading ?	79
What the way to stop a long running thread ?	80
How do I debug thread ?	80
What is Thread.Join() in threading ?	81
What are Daemon threads and how can a thread be created as Daemon?	81
When working with shared data in threading how do you implement synchronization ?	81
Can we use events with threading ?	82
How can we know a state of a thread?	82
What is a monitor object?	82
What are wait handles ?	83
<i>Twist :- What is a mutex object ?</i>	<i>83</i>
What is ManualResetEvent and AutoResetEvent ?	83

What is ReaderWriter Locks ?	83
How can you avoid deadlock in threading?	84
What is the difference between thread and process?	84
4. Remoting and Webservice	85
What is an application domain?	85
What is .NET Remoting ?	85
Which class does the remote object has to inherit ?	86
What are two different types of remote object creation mode in .NET ?	86
Describe in detail Basic of SAO architecture of Remoting?	86
What are the situations you will use singleton architecture in remoting ?	91
What is fundamental of published or precreated objects in Remoting ?	91
What are the ways in which client can create object on server in CAO model ?	91
Are CAO stateful in nature ?	92
In CAO model for client objects to be created by “NEW” keyword what should we do?	92
Is it a good design practice to distribute the implementation to Remoting Client ?	93
What are LeaseTime, SponsorshipTime, RenewonCallTime and LeaseManagerPollTime?	93
Which config file has all the supported channels/protocol ?	94
How can you specify remoting parameters using Config files ?	95
Can Non-Default constructors be used with Single Call SAO?	97
<i>Twist :- What are the limitation of constructors for Single call SAO ?</i>	<i>97</i>
How can we call methods in remoting Asynchronously ?	98
What is Asynchronous One-Way Calls ?	98
What is marshallng and what are different kinds of marshallng ?	98
What is ObjRef object in remoting ?	99
What is a Web Service ?	99
What is UDDI ?	100
What is DISCO ?	100
What is WSDL?	100
What the different phase/steps of acquiring a proxy object in Webservice ?	100
What is file extension of Webservices ?	101
Which attribute is used in order that the method can be used as Webservice ?	102
What are the steps to create a webservice and consume it ?	102
Do webservice have state ?	111
5. Caching Concepts	113
What is an application object ?	113
What’s the difference between Cache object and application object ?	113
How can get access to cache object ?	113
What are dependencies in cache and types of dependencies ?	113
Can you show a simple code showing file dependency in cache ?	114
What is Cache Callback in Cache ?	114
What is scavenging ?	115
What are different types of caching using cache object of ASP.NET?	115
How can you cache different version of same page using ASP.NET cache object ?	115
How will implement Page Fragment Caching ?	116
Can you compare ASP.NET sessions with classic ASP?	116
Which various modes of storing ASP.NET session ?	116

Is Session_End event supported in all session modes ?	117
What are the precautions you will take in order that StateServer Mode work properly ?	117
What are the precautions you will take in order that SQLSERVER Mode work properly ?	117
Where do you specify session state mode in ASP.NET ?	118
What are the other ways you can maintain state ?.....	118
What are benefits and Limitation of using Hidden fields ?	118
What is ViewState ?	119
Does the performance for viewstate vary according to User controls ?	119
What are benefits and Limitation of using Viewstate for state management?	119
How can you use Hidden frames to cache client data ?	120
What are benefits and limitations of using Hidden frames?.....	120
What are benefits and limitations of using Cookies?	121
What is Query String and What are benefits and limitations of using Query Strings?	121
6. OOPS	135
What is Object Oriented Programming ?	135
What's a Class ?	135
What's an Object ?.....	135
What is the relation between Classes and Objects ?	135
What are different properties provided by Object-oriented systems ?	135
<i>Twist :- Can you explain different properties of Object Oriented Systems?</i>	<i>135</i>
<i>Twist :- What is difference between Association, Aggregation and Inheritance relationships?</i>	<i>136</i>
How can we achieve inheritance in VB.NET ?	137
What are abstract classes ?	138
What is a Interface ?	140
What is difference between abstract classes and interfaces?	142
What is a delegate ?	142
What are events ?.....	143
Do events have return type ?	145
Can event's have access modifiers ?	145
Can we have shared events ?	145
What is shadowing ?.....	145
What is the difference between Shadowing and Overriding ?	146
What is the difference between delegate and events?	146
If we inherit a class do the private variables also get inherited ?	147
What are the different accessibility levels defined in .NET ?	147
Can you prevent a class from overriding ?	147
What is the use of "MustInherit" keyword in VB.NET ?	147
Do interface have accessibility modifier?	148
What are similarities between Class and structure ?	148
What is the difference between Class and structure's ?	148
What does virtual keyword mean ?	148
What are shared (VB.NET)/Static(C#) variables?	148
What is Dispose method in .NET ?	150
What is the use of "OverRides" and "Overridable" keywords ?	150
Where are all .NET Collection classes located ?	150
What is ArrayList ?.....	151
What's a HashTable ?	151

<i>Twist :- What's difference between HashTable and ArrayList ?</i>	151
What are queues and stacks ?	151
What is ENUM ?	151
What is nested Classes ?	151
What is Operator Overloading in .NET?	152
In below sample code if we create a object of class2 which constructor will fire first ?	152
What is the significance of Finalize method in .NET?	152
Why is it preferred to not use finalize for clean up?	153
How can we suppress a finalize method?	154
What is the use of DISPOSE method?	154
How do I force the Dispose method to be called automatically?	155
In what instances you will declare a constructor to be private?	155
Can we have different access modifiers on get/set methods of a property ?	156
If we write a goto or a return statement in try and catch block will the finally block execute ?	156
What is Indexer ?	156
Can we have static indexer in C# ?	156
What is the difference between System.String and System.StringBuilder classes?	156
7. ASP.NET	157
What' is the sequence in which ASP.NET events are processed ?	157
In which event are the controls fully loaded ?	157
How can we identify that the Page isPostBack ?	157
How does ASP.NET maintain state in between subsequent request ?	157
What is event bubbling ?	157
How do we assign page specific attributes ?	158
If we want to make sure that no one has tampered with ViewState, how do we ensure it?	158
What is the use of @ Register directives ?	158
What's the use of SmartNavigation property ?	158
What is AppSetting Section in "Web.Config" file ?	158
Where is ViewState information stored ?	158
What is the use of @ OutputCache directive in ASP.NET?	159
How can we create custom controls in ASP.NET ?	159
How many types of validation controls are provided by ASP.NET ?	159
Can you explain what is "AutoPostBack" feature in ASP.NET ?	160
How can you enable automatic paging in DataGrid ?	160
What's the use of "GLOBAL.ASAX" file ?	160
What is the difference between "Web.config" and "Machine.Config" ?	160
What is a SESSION and APPLICATION object ?	161
What is the difference between Server.Transfer and response.Redirect ?	161
What is the difference between Authentication and authorization?	161
What is impersonation in ASP.NET ?	162
Can you explain in brief how the ASP.NET authentication process works?	162
What are the various ways of authentication techniques in ASP.NET?	163
How does authorization work in ASP.NET?	165
What's difference between Datagrid, Datalist and repeater ?	166
From performance point of view how do they rate ?	167
What is the method to customize columns in DataGrid?	167
How can we format data inside DataGrid?	167

How to decide on the design consideration to take a Datagrid, datalist or repeater ?	167
Difference between ASP and ASP.NET?	167
What are major events in GLOBAL.ASAX file ?	169
What order they are triggered ?	170
Do session use cookies ?	171
How can we force all the validation control to run ?	171
How can we check if all the validation control are valid and proper ?	171
If client side validation is enabled in your Web page, does that mean server side code is not run?	171
Which JavaScript file is referenced for validating the validators at the client side ?	171
How to disable client side script in validators?	172
How can I show the entire validation error message in a message box on the client side?	172
If validation are complicated and does not fit in any of the validators, what will you do ?	172
What is Tracing in ASP.NET ?	173
How do we enable tracing ?	173
What exactly happens when ASPX page is requested from Browser?	173
How can we kill a user session ?	177
How do you upload a file in ASP.NET ?	178
How do I send email message from ASP.NET ?	178
What are different IIS isolation levels?	178
ASP uses STA threading model, what is the threading model used for ASP.NET ?	180
What is the use of <% @ page aspcompat=true %> attribute ?	180
Explain the differences between Server-side and Client-side code?	181
Can you explain Forms authentication in detail ?	181
How do I sign out in forms authentication ?	183
If cookies are not enabled at browser end does form Authentication work?	183
How to use a checkbox in a datagrid?	183
What are the steps to create a windows service in VB.NET ?	184
What is the difference between “Web farms” and “Web garden”?	185
How do we configure “WebGarden”?	188
What is the main difference between GridLayout and FlowLayout ?	191
8..NET Architecture	192
What are design patterns ?	192
What is the difference between Factory and Abstract Factory Patterns?	193
What is MVC pattern?	196
<i>Twist: - How can you implement MVC pattern in ASP.NET?</i>	196
How can we implement singleton pattern in .NET?	198
How do you implement prototype pattern in .NET?	199
<i>Twist: - How to implement cloning in .NET ? What is shallow copy and deep copy ?</i>	199
What are the situations you will use a Web Service and Remoting in projects?	199
Can you give a practical implementation of FAÇADE patterns?	199
How can we implement observer pattern in .NET?	201
What is three tier architecture?	201
Have you ever worked with Microsoft Application Blocks, if yes then which?	202
What is Service Oriented architecture?	202
What are different ways you can pass data between tiers?	205
What is Windows DNA architecture?	205
What is aspect oriented programming?	207

9. ADO.NET	216
What is the namespace in which .NET has the data functionality classes ?	216
Can you give a overview of ADO.NET architecture ?	216
What are the two fundamental objects in ADO.NET ?	218
What is difference between dataset and datareader ?	218
What are major difference between classic ADO and ADO.NET ?	218
What is the use of connection object ?	218
What is the use of command objects ?	219
What is the use of dataadapter ?	219
What are basic methods of Dataadapter ?	219
What is Dataset object?	220
What are the various objects in Dataset ?	220
How can we connect to Microsoft Access , Foxpro , Oracle etc ?	220
How do we connect to SQL SERVER, which namespace do we use ?	221
How do we use stored procedure in ADO.NET ?	226
How can we force the connection object to close after my datareader is closed ?	227
I want to force the datareader to return only schema of the datastore rather than data ?	227
How can we fine tune the command object when we are expecting a single row ?	227
Which is the best place to store connectionstring in .NET projects ?	227
What are the steps involved to fill a dataset ?	228
<i>Twist :- How can we use dataadapter to fill a dataset ?</i>	<i>228</i>
What are the various methods provided by the dataset object to generate XML?	229
How can we save all data from dataset ?	229
How can we check that some changes have been made to dataset since it was loaded ?	230
<i>Twist :- How can we cancel all changes done in dataset ?</i>	<i>230</i>
<i>Twist :- How do we get values which are changed in a dataset ?</i>	<i>230</i>
How can we add/remove row's in "DataTable" object of "DataSet" ?	230
What is basic use of "DataView" ?	231
What is the difference between "DataSet" and "DataReader" ?	232
<i>Twist :- Why is DataSet slower than DataReader ?</i>	<i>232</i>
How can we load multiple tables in a DataSet ?	232
How can we add relation's between table in a DataSet ?	233
What is the use of CommandBuilder ?	233
What's difference between "Optimistic" and "Pessimistic" locking ?	234
How many ways are there to implement locking in ADO.NET ?	234
How can we perform transactions in .NET?	235
What is difference between Dataset. clone and Dataset. copy ?	235
Can you explain the difference between an ADO.NET Dataset and an ADO Recordset?	235
Explain in detail the fundamental of connection pooling?	236
What is Maximum Pool Size in ADO.NET Connection String?	237
10. SQL SERVER	238
What is normalization? What are different types of normalization?	238
What is denormalization ?	240
What is a candidate key ?	241
What are the different types of joins? What is the difference between them ?	241
What are indexes? What is the difference between clustered and nonclustered indexes?	242

How can you increase SQL performance ?	242
What is the use of OLAP ?	243
What is a measure in OLAP ?.....	243
What are dimensions in OLAP ?	243
What are levels in dimensions ?	244
What are fact tables and dimension tables in OLAP ?	244
<i>Twist :- Can you explain the star schema for OLAP ?</i>	<i>244</i>
What is DTS?.....	244
What is fillfactor ?	244
<i>Twist :- When does page split occurs ?</i>	<i>244</i>
What is RAID and how does it work ?.....	245
What is the difference between DELETE TABLE and TRUNCATE TABLE commands?	246
What are different transaction levels in SQL SERVER?	247
<i>Twist :- What are different types of locks in SQL SERVER ?</i>	<i>247</i>
What are the different locks in SQL SERVER ?	248
Can we suggest locking hints to SQL SERVER ?	250
What is LOCK escalation?	250
What are the different ways of moving data between databases in SQL Server?	250
What are advantages of SQL 2000 over SQL 7.0 ?	251
What is the difference between a HAVING CLAUSE and a WHERE CLAUSE?	252
What is the difference between UNION and UNION ALL SQL syntax ?	252
How can you raise custom errors from stored procedure ?	252
What is ACID fundamental? What are transactions in SQL SERVER ?.....	254
What is DBCC?	255
What is the purpose of Replication ?.....	257
What are the different types of replication supported by SQL SERVER ?	258
What is BCP utility in SQL SERVER ?.....	258
What are the different types of triggers in SQL SERVER 2000 ?	260
If we have multiple AFTER Triggers on table how can we define the sequence of the triggers ? ..	261
What is SQL injection ?	261
What is the difference between Stored Procedure (SP) and User Defined Function (UDF)?	262
11. UML.....	277
What is UML?	277
How many types of diagrams are there in UML ?.....	277
<i>Twist :- Explain in short all types of diagrams in UML ?</i>	<i>277</i>
What are advantages of using UML?	279
<i>Twist: - What is Modeling and why UML ?</i>	<i>279</i>
What is the sequence of UML diagrams in project?	279
<i>Twist: - How did you implement UML in your project?</i>	<i>279</i>
<i>Just a small Twist: - Do I need all UML diagrams in a project?</i>	<i>280</i>
Give a small brief explanation of all Elements in activity diagrams?	284
Explain Different elements of a collaboration diagram ?	286
Explain Component diagrams ?.....	287
Explain all parts of a deployment diagram?	289
Describe the various components in sequence diagrams?.....	291
What are the element in State Chart diagrams ?.....	293
Describe different elements in Static Chart diagrams ?	295

Explain the different elements of a Use Case ?	297
<i>Twist: - What is the difference between Activity and sequence diagrams?</i>	<i>299</i>
12. Project Management	300
What is project management?	300
Is spending in IT projects constant through out the project?	300
Who is a stakeholder ?	301
Can you explain project life cycle ?	301
<i>Twist :- How many phases are there in software project ?</i>	<i>301</i>
Are risk constant through out the project ?	303
Can you explain different software development life cycles ?	304
What is triple constraint triangle in project management ?	307
What is a project baselines ?	308
What is effort variance?	308
How is normally a project management plan document organized ?	308
How do you estimate a project?	308
What is CAR (Causal Analysis and Resolution)?	309
What is DAR (Decision Analysis and Resolution) ?	309
What is a fish bone diagram ?	309
<i>Twist:- What is Ishikawa diagram ?</i>	<i>309</i>
What is pareto principle ?	310
<i>Twist :- What is 80/20 principle ?</i>	<i>311</i>
How do you handle change request?	311
What is internal change request?	311
What is difference between SITP and UTP in testing ?	311
What is the software you have used for project management?	311
What are the metrics followed in project management?	312
<i>Twist: - What metrics will you look at in order to see the project is moving successfully?</i>	<i>312</i>
Some people in your team do not meet there deadlines what are the actions you will take ?	315
<i>Twist :- Two of your resources have conflicts between them how would you sort it out ?</i>	<i>315</i>
What is black box testing and White box testing?	315
What's the difference between Unit testing, Assembly testing and Regression testing?	316
What is V model in testing?	318
How do you start a project?	321
How did you do resource allocations?	321
How will you do code reviews ?	321
What is CMMI?	321
What are the five levels in CMMI?	321
What is continuous and staged representation?	325
Can you explain the process areas?	329
What is SIX sigma?	347
What is DMAIC and DMADV ?	348
What are the various roles in Six Sigma implementation?	349
What are function points?	350
<i>Twist: - Define Elementary process in FPA?</i>	<i>350</i>
What are the different types of elementary process in FPA?	350
What are the different elements in Functions points?	350
Can you explain GSC and VAF in function points?	356

What are unadjusted function points and how is it calculated?	358
Can you explain steps in function points?	359
What is the FP per day in your current company?	359
<i>Twist :- What is your company's productivity factor ?</i>	<i>359</i>
Do you know Use Case points?	359
What is COCOMO I, COCOMOII and COCOMOIII?	359
What is SMC approach of estimation?	359
How do you estimate maintenance project and change requests?	360
13. XML	361
What is XML?	361
What is the version information in XML?	361
What is ROOT element in XML?	361
If XML does not have closing tag will it work?	361
Is XML case sensitive?	362
What is the difference between XML and HTML?	362
Is XML meant to replace HTML?	362
Can you explain why your project needed XML?	362
What is DTD (Document Type definition)?	362
What is well formed XML?	362
What is a valid XML?	363
What is CDATA section in XML?	363
What is CSS?	363
What is XSL?	363
What is element and attributes in XML?	363
Which are the namespaces in .NET used for XML?	363
What are the standard ways of parsing XML document?	363
In What scenarios will you use a DOM parser and SAX parser?	368
How was XML handled during COM times?	368
What is the main difference between MSXML and .NET Framework XML classes?	368
What are the core functionalities in XML .NET framework?	368
What is XSLT?	369
Define XPATH?	370
What is the concept of XPOINTER?	370
What is an XMLReader Class?	371
What is XMLTextReader?	371
How do we access attributes using "XmlReader"?	372
Explain simple Walk through of XmlReader ?	372
What does XmlValidatingReader class do?	375
14. Localization/Globalization	376
What is Unicode and why was it introduced?	376
Does .NET support UNICODE and how do you know it supports?	377
What's the difference between localization and globalization?	377
What architecture decisions you should consider while planning for international software's?	378
How do we get the current culture of the environment in windows and ASP.NET?	380
Which are the important namespaces during localization and globalization?	383
What are resource files and how do we generate resource files?	384

Can resource file be in any other format other than resx extensions?	385
How is resource files actually used in project?	385
How can we use Culture Auto in project?	385
What are satellite assemblies?	388
How do we generate Satellite assemblies?	388
What is AL.EXE and RESGEN.EXE?	388
What's the use of resource manager class?	390
What precautions do we need to take while deploying satellite assemblies?	390
Can we get a strongly typed resource class rather than using resource manager?	391
Explain the fundamentals of "GetGlobalResourceObject" and "GetLocalResourceObject" ?	394
Can we sign a satellite assembly?	394
Can you explain collation sequence in sql server?	394
How do we define collation sequence for database and tables?	395
Can we change the order in a select query with a specified collation sequence?	396
Can you list best practices for globalization and localization?	396
Why is the culture set to the current thread?	397
15. Windows Communication Framework (Vista Series)	399
What is .NET 3.0	399
What is Windows CardSpace ?	399
What is WCF?	399
What are the important principles of SOA (Service oriented Architecture)?	403
What are end points, contract, address and bindings?	404
Which specifications does WCF follow?	406
What are the main components of WCF?	407
Can you explain how End points, Contract, Address and Bindings are done in WCF?	407
What is a service class?	407
What is a service contract, operation contract and Data Contract?	407
What are the various ways of hosting a WCF service?	414
How do we host a WCF service in IIS?	414
What are the advantages of hosting WCF Services in IIS as compared to self hosting?	420
What are the major differences between services and Web services?	421
What is the difference WCF and Web services?	421
What are different bindings supported by WCF?	421
Which are the various programming approaches for WCF?	422
What is one way operation?	422
Can you explain duplex contracts in WCF?	424
How can we host a service on two different protocols on a single server?	428
How can we use MSMQ bindings in WCF?	431
Can you explain transactions in WCF?	435
What different transaction isolation levels provided in WCF?	435
Can we do transactions using MSMQ?	437
Can we have two way communications in MSMQ?	439
What are Volatile queues?	440
What are Dead letter queues?	441
What is a poison message?	441
16. Windows Presentation Framework (Vista Series)	443

What is WPF?	443
What is XAML?	443
What are dependency properties?	443
Are XAML file compiled or built on runtime?	444
Can you explain how we can separate code and XAML?	444
How can we access XAML objects in behind code?	446
What are the kind of documents are supported in WPF?	446
17. Windows workflow foundation(Vista series)	448
What is Windows Workflow Foundation?	448
What is a Workflow?	448
What are different types of Workflow in Windows Workflow foundation?	449
When should we use a sequential workflow and when should we use state machines?	450
How do we create workflows using designer?	453
How do we specify conditions in Work flow?	454
How do you handle exceptions in workflow?	456
What is the use of XOML files?	457
Twist: - How can we serialize workflows?	457
How can we pass parameters to workflow?	459
18.ATLAS-AJAX	461
What problem does Ajax solve?	461
What is Ajax?	462
What is the basic fundamental behind Ajax?	462
What is JSON?	462
How do we use XMLHttpRequest object in JavaScript?	463
How do we do asynchronous processing using Ajax?	464
What are the various states in XMLHttpRequest and how do we check the same?	464
How can we get response text?	465
How can we send request to the server using the XMLHttpRequest component?	465
How do we pass parameters to the server?	466
How can we create a class in JavaScript using Atlas?	466
How do we do inheritance using Atlas?	470
How do we define interfaces using Atlas?	470
How do we reference HTML controls using Atlas?	471
Can you explain server controls in Atlas?	471
Can you explain ScriptManager control?	471
What is the importance of UpdatePanel Control?	471
Can you explain update progress control?	471
Can you explain control extenders?	471
How can we data binding in Atlas?	471
Can you explain AtlasUIGlitz library?	471
I want to create a project like Google maps how can we do that with Atlas?	471
How can we integrate Atlas with Web services?	472
How can implement drag and drop using Atlas?	472
How do we do authentications using Atlas?	472
How can we access profiles using Atlas?	472
How can we access dataset in Atlas?	472

We have custom data type on a web service how do we access the same in Atlas?	472
19. Sample Projects	473
Approach to complete the projects	473
Address book	475
Mini-job site	476
Chat application	482
Reminder Application	483
Complete implementation of address book application	485
Use Case Document for address book application	486
Estimation	487
Assumption Sections	490
Technical Design Document	490
Overview	490
Architecture approach	490
ER Diagram	491
Database Layer	491
Business Layer	499
Presentation Layer	503
Test plans	508
Source code	510
20. Test Yourself	514
21. Free exams	525
22. Pending Topics	526

“Cheers to the true fighting spirit of IT professionals”

Introduction

Dedication

This book is dedicated to my kids Sanjana and Simran, whose dad's play time has been stolen and given to this book. I am thankful to my wife for constantly encouraging me and also to BPB Publication to give new comer a platform to perform. Finally on top of all thanks to the two old eyes my mom and dad for always blessing me. I am blessed to have Raju as my brother who always keeps my momentum moving on.

I am grateful to Bhavnesh Asar who initially conceptualized the idea I believe concept thinking is more important than execution. Tons of thanks to my reviewers whose feedback provided an essential tool to improve my writing capabilities.

Just wanted to point out Miss Kadambari . S. Kadam took all the pain to review for the left outs with out which this book would have never seen the quality light.

About the author

Author works in a big multinational company and has a good experience in software industry. He is working presently as project lead and in past has led projects in banking, travel and financial sectors.

But on top of all, I am a simple developer like you all guys there doing an 8 hour job. Writing is something I do extra and I love doing it. No one is perfect and same holds true for me .So anything you want to comment, suggest, and point typo / grammar mistakes or technical mistakes regarding the book you can mail me at shiv_koirala@yahoo.com. Believe me guys your harsh words would be received with love and treated to the top most priority. Without all you guys I am not an author.

Writing an interview question book is really a great deal of responsibility. I have tried to cover maximum questions for the topic because I always think probably leaving one silly question will cost someone's job there. But huge natural variations in an interview are something difficult to cover in this small book. So if you have come across such questions during interview which is not addressed in this book do mail at shiv_koirala@yahoo.com .Who knows probably that question can save some other guys job.

Features of the book

- √ Around 400 plus interview questions from live .NET interviews.

-
- √ Section wise .NET interview question coverage according to multinational companies.
 - √ Short and to the point answers (no hitting around the bush).
 - √ Every question is classified in to Basic,Intermediate and advanced category, thus providing more focus to readers on specific category.
 - √ Covers latest technology like Ajax , WCF , WPF and WWF.
 - √ During interviews other than main technology (.NET, JAVA etc.) companies expect other areas to be strong for example UML, Architecture, Database etc. Other sections is the most strong point of the book, which makes reader prepared for the unexpected questions.
 - √ Full range of interview questions right from junior .NET developers to senior architects or project manager.
 - √ CD has sample resume, sample dummy project and sample code to understand fundamentals..
 - √ Book covers important points like salary negotiations, resume making and general points to be remembered during interview.
 - √ Recommended for .NET interviewers who are looking for what questions to be asked to get better and decent .NET professionals
 - √ Recommended for Fresher and students who want to have a feel of what .NET questions are asked in multinational companies.
 - √ Developers who are looking for Quick reference and FAQ.

I am sure after reading this book readers will have extra confidence and a better approach for .NET interviews.

Introduction

When we look back at times of COBOL, PASCAL features provided by these languages where minimal. More emphasis was on completing projects than on quality of code. As features provided by languages where less, programmer had to code everything from scratch. For example to write a simple sorting logic you have to write your own sorting algorithm. As languages grew and started becoming mature, these logic where in-built

feature of language. As feature list of languages started growing programmer's became feature specialist rather than specialist of whole language.

If a developer who is working for past two to three years on remoting is a remoting specialist, but probably in ADO.NET he has minimal knowledge. Now after working day & night and becoming specialist he is looking for a job. But the bad part of IT industry today is that they do not look for specialist rather they look for developers who have fair knowledge of over all feature of the language. This remoting specialist stumbles with simple ADO.NET and SQL questions during interview. But guys that's ok when you are working and concentrating on one particular aspect it's but obvious that you will forget these fundamentals.

Software clients no more look source code as the only one deliverable, but even other documents like SRS (System Requirement documents), SDD (System Design Documents), Test Plans (SITP and UTP) etc. as a integral part of project. IT multinationals are now looking from both technical and process aspect of the project. So going with pure .NET technical fundamentals will only take you to a programmer position, but know how of documenting project, UML understanding, SDLC cycle etc will take you to a better position (Project Manager, Program Manager, Senior architect etc).

This book covers the other aspect of .NET interview's by providing chapter like Architecture, UML, SQL SERVER, Project Management, General Interview questions etc.

I hope this book takes you to a better height and gives you extra confidence boost during int erview's. Best of Luck and Happy Job-Hunting.....

How to read this book

If you can read English, you can read this book....kidding. There are some legends which will make your reading more effective. Every question has simple tags which mark the rating of the questions.

These rating are given by Author and can vary according to companies and individuals.

(B) Basic Questions

Basic Grade means according to the interviewer it's a fundamental question and should be answered. Example What is a CLR ? Guy's stumbling on this question will rarely pass interviews.

(I) Intermediate Questions

These are Mid-level questions and will be expected to be answered if you are looking for a decent position in the company.

(A) Advanced Questions

These are advanced level question which are expected when they are looking for specialist in the field.

(P) Psyche Questions

These level of questions do not judge anything for a candidate but see it as a attitude problem of the interviewer.

*** Marked Questions**

These are general questions asked in IT world. Example “What’s your expectation?” You will see these question’s as you keep reading. There are no direct answers to these question but they do affect a lot during job search. Be ready with some decent answers.

Note

While reading you can come across section marked as “Note”, which highlight special points of that section.

Software Company hierarchy

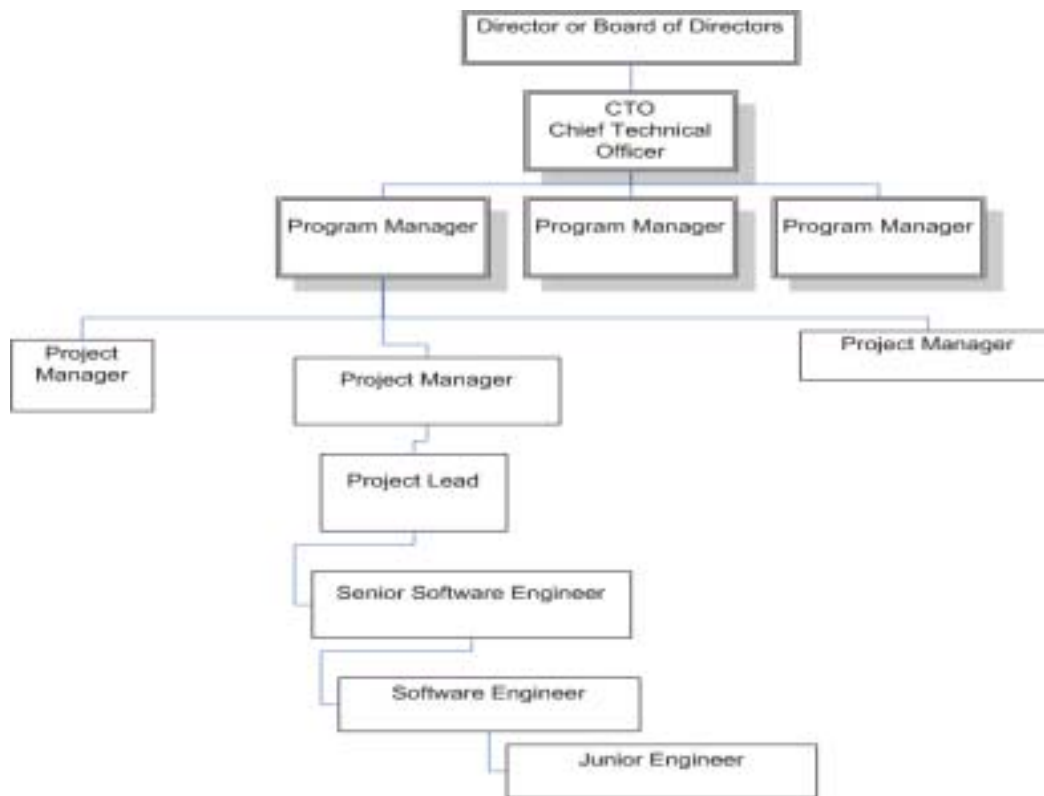

Figure :- 0.1 IT Company hierarchy

Its very important during interview to be clear about what position you are targeting. Depending on what positions you are targeting the interviewer shoots you questions. Example if you are looking for a project manager position you will be asked around 20% technical questions and 80% management.

Note:- In small scale software house and mid scale software companies there are chances where they expect a PM to be very much technical. But in big software houses the situations are very much different, interview are conducted according to positions.... Unless the interviewer changes the rule.

Above is a figure of a general hierarchy across most IT companies.

Note:- There are many small and medium software companies which do not follow this hierarchy and they have their own adhoc way of defining positions in the company.

So why is the need of hierarchy in an interview.

“Interview is a contract between the employer and candidate to achieve specific goals.”

So employer is looking for a suitable candidate and candidate looks for a better career. Normally in interviews the employer is very clear about what type of candidate he is looking for. But 90% times the candidate is not clear about the positions he is looking for.

How many times it has happened with you that you have given a whole interview and when you mentioned the position you are looking for...pat comes the answer, “ we do not have any requirements for this position”. So be clarified about the position right from when you start the interview.

Following are the number of years of experience according to position.

- √ Junior engineers are specially fresher and work under software engineers.
- √ Software engineers have around 1 to 2 years of experience. Interviewer expects software engineers to be technically at a medium level.
- √ Senior Software Engineers have around 2 to 4 years of experience. Interviewer expects them to technically be very strong.
- √ Project leads should handle majority technical aspect of project and should have around 4 to 8 years of experience. They are also indirect architect of the project. Interviewer expects them to be technically strong and in terms of architecture to be decent. Interviewer also expects them to have people management skills.
- √ Project Manager are expected to be around 40% technically strong and should have experience above 10 years plus. But they are more interviewed from aspect of project management, client interaction, people management, proposal preparation etc.

So now judge where you stand, and where you want to go.....

Resume Preparation Guidelines

First impression the last impression

Note :- A sample resume is provided in "SampleResume" folder.

Before even the interviewer meets you he will first meet your resume. Interviewer looking at your resume is almost a 20% interview happening with out you knowing it. I was always a bad guy when it comes to resume preparation. But when I looked at my friends resume they where gorgeous. Now that I am writing series of book on interviews I thought this will be a good point to put in. You can happily skip it if you are confident about your resume. There is no hard and fast rule that you have to follow the same pattern but just see if these all check list are attended.

- √ Use plain text when you are sending resumes through email. For instance you sent your resume using Microsoft word and what if the interviewer is using Linux he will never be able to read your resume. You can not be sure both wise, you sent your resume in Word 2000 and the guy has Word 97...uuhhh.
- √ Attach a covering letter it really impresses and makes you look traditionally formal. Yes, even if you are sending your CV through email send a covering letter.

Check list of content you should have in your resume :-

- √ Start with an objective or summary, for instance, "Working as a Senior Database administrator for more than 4 years. Implemented quality web based application. Follow the industry's best practices and adhered and implemented processes, which enhanced the quality of technical delivery. Pledge to deliver the best technical solutions to the industry."
- √ Specify your Core strengths at the start of the resume by which the interviewer can make a quick decision are you eligible for the position. For example :-
 - Looked after data mining and data warehousing department independently. Played a major role in query optimization.
 - Worked extensively in database design and ER diagram implementation.
 - Well versed with CMMI process and followed it extensively in projects.
 - Looking forward to work on project manager or senior manager position.

This is also a good position to specify your objective or position which makes it clear to the interviewer that should he call you for an interview. For instance, if you are looking for senior position specify it explicitly 'looking for this job profile'. Any kind of certification like MCP, MCSD etc you can make it visible in this section.

-
- √ Once you have specified briefly your goals and what you have done its time to specify what type of technology you have worked with. For instance RDBMS, TOOLS, Languages, Web servers, process (Six sigma, CMMI).
 - √ After that you can make a run through of your experience company wise that is what company you have worked with, year / month joining and year / month left. This will give an overview to the interviewer what type of companies you have associated your self.

Now its time to mention all your projects you have worked till now. Best is to start in descending order that is from your current project and go backwards. For every project try to put these things :-

- √ Project Name / Client name (It's sometimes unethical to mention clients name; I leave it to the readers).
- √ Number of team members.
- √ Time span of the project.
- √ Tools, language, RDBMS and technology used to complete the project.
- √ Brief summary of the project.

Senior people who have huge experience will tend to increase there CV with putting in summary for all project. Best for them is to just put description of the first three projects in descending manner and rest they can say verbally during interview. I have seen CV above 15 pages... I doubt who can read it.

- √ Finally comes your education and personal details.
- √ Trying for onsite, do not forget to mention your passport number.
- √ Some guys tend to make there CV large and huge. I think an optimal size should be not more than 4 to 5 pages.
- √ Do not mention your salary in CV. You can talk about it during interview with HR or the interviewer.
- √ When you are writing your summary for project make it effective by using verbs like managed a team of 5 members, architected the project from start to finish etc. It brings huge weight.

-
- √ This is essential very essential take 4 to 5 Xerox copies of your resume you will need it now and then.
 - √ Just in case take at least 2 passport photos with you. You can escape it but many times you will need it.
 - √ Carry all your current office documents specially your salary slips and joining letter.

Salary Negotiation

Ok that's what we all do it for money... not everyone. This is probably the weakest area for techno savvy guys. They are not good negotiators. I have seen so many guys at the first instance they will smile and say "NEGOTIABLE SIR". So here are some points:-

- √ Do a study of what is the salary trend? For instance have some kind of baseline. For example what is the salary trend on number of year of experience? Discuss this with your friends out.
- √ Do not mention your expected salary on the resume?
- √ Let the employer first make the salary offer. Try to delay the salary discussion till the end.
- √ If they say what you expect ?, come with a figure with a little higher end and say negotiable. Remember never say negotiable on something which you have aimed, HR guys will always bring it down. So negotiate on AIMED SALARY + some thing extra.
- √ The normal trend is that they look at your current salary and add a little it so that they can pull you in. Do your home work my salary is this much and I expect this much so whatever it is now I will not come below this.
- √ Do not be harsh during salary negotiations.
- √ It's good to aim high. For instance I want 1 billion dollars / month but at the same time be realistic.
- √ Some companies have those hidden cost attached in salary clarify that rather to be surprised at the first salary package.
- √ Many of the companies add extra performance compensation in your basic which can be surprising at times. So have a detail break down. Best is to discuss on hand salary rather than gross.

-
- √ Talk with the employer in what frequency does the hike happen.
 - √ Take everything in writing, go back to your house and have a look once with a cool head is the offer worth it of what your current employer is giving.
 - √ Do not forget once you have job in hand you can come back to your current employer for negotiation so keep that thing in mind.
 - √ Remember the worst part is cribbing after joining the company that your colleague is getting more. So be careful while interview negotiations or be sportive to be a good negotiator in the next interview.
 - √ One very important thing is that the best negotiation ground is not the new company where you are going but the old company which you are leaving. So once you have offer on hand get back to your old employee and show them the offer and then make your next move. It's my experience that negotiating with the old employer is easy than with the new one....Frankly if approached properly rarely any one will say no. Just do not be aggressive or egoistic that you have an offer on hand.

Top of all some time some things are worth above money :- JOB SATISFACTION. So whatever you negotiate if you think you can get JOB SATISFACTION aspect on higher grounds go for it. I think its worth more than money.

Applicable to only India	
Years of Experience	Amount in Rupees CTC (Cost to Company)
Fresher's	5000 to 8000
1 to 2 yrs	10000 to 20000
3 to 4 yrs	25000 to 30000
4 to 6 yrs	30000 to 40000
6 to 8 yrs	40000 to 60000
12 to 15 yrs	70000 to 100000
15 yrs and above	Depends upon negotiations

Figure :- 0.2 Salary Card for India

Applicable to US Only	
Years of Exp	Amount in Dollars (Per Annum)
Freshers	40000 to 50000 Dollars
2 to 4 yrs	50000 to 55000 Dollars
4 to 6 yrs	55000 to 60000 Dollars
6 to 8 yrs	60000 to 70000 Dollars
8 to 12 yrs	70000 to 80000 Dollars
12 yrs and above	Depends on negotiations
Note: - If you are a Non-US resident like Indian, Philippine etc who is going on H1 then you start from a fresher level or the 2 to 4 yrs of salary slab. Also one note if you come back from US and then want to try again how much ever experience you have you will need to start from the either of first three slabs.	

Figure :- 0.3 US Salary Card

Note: - The above US Salary card is based on my experience and some talk which I had with my friends who are staying on longer term basis outside. In case you are finding discrepancies please do mail me at shiv_koirala@yahoo.com probably we can standardize it better for the community.

The score card shown above is completely derived from author's experience and interaction he had in his circle. It is not an approved score card by any authorized body as such and should be taken only has bench mark to measure your success. Also note that these rates are applicable for medium and large software companies. Small company rate cards are very irregular and governed by a single owner of the company. So the above rate card is not applicable for small company. Many people do get mind blowing salaries even with small experience which again the score card does not reflect.

Points to remember

- √ One of the first questions asked during interview is “Can you say something about yourself”?
- √ Can you describe about your self and what you have achieved till now?
- √ Why do you want to leave the current company?
- √ Where do you see yourself after three years?

-
- √ What are your positive and negative points?
 - √ How much do you rate yourself in .NET and SQL Server in one out of ten?
 - √ Are you looking for onsite opportunities? (Be careful do not show your desperation of abroad journeys)
 - √ Why have you changed so many jobs? (Prepare a decent answer do not blame companies and individuals for your frequent change).
 - √ Never talk for more than 1 minute straight during interview.
 - √ Have you worked with previous version of SQL Server?
 - √ Would you be interested in a full time Database administrator job?
 - √ Do not mention client names in resume. If asked say that it's confidential which brings ahead qualities like honesty
 - √ When you make your resume keep your recent projects at the top.
 - √ Find out what the employer is looking for by asking him questions at the start of interview and best is before going to interview. Example if a company has projects on server products employer will be looking for BizTalk, CS CMS experts.
 - √ Can you give brief about your family background?
 - √ As you are fresher do you think you can really do this job?
 - √ Have you heard about our company ? Say five points about our company? Just read at least once what company you are going for?
 - √ Can you describe your best project you have worked with?
 - √ Do you work on Saturday and Sunday?
 - √ Which is the biggest team size you have worked with?
 - √ Can you describe your current project you have worked with?
 - √ How much time will you need to join our organization? What's notice period for your current company?
 - √ What certifications have you cleared?
 - √ Do you have pass port size photos, last year mark sheet, previous companies employment letter, last months salary slip, pass port and other necessary documents.

-
- √ What is the most important thing that motivates you?
 - √ Why you want to leave the previous organization?
 - √ Which type of job gives you greatest satisfaction?
 - √ What is the type of environment you are looking for?
 - √ Do you have experience in project management?
 - √ Do you like to work as a team or as individual?
 - √ Describe your best project manager you have worked with?
 - √ Why should I hire you?
 - √ Have you been ever fired or forced to resign?
 - √ Can you explain some important points that you have learnt from your past project experiences?
 - √ Have you gone through some unsuccessful projects, if yes can you explain why did the project fail?
 - √ Will you be comfortable with location shift? If you have personal problems say no right at the first stage.... or else within two months you have to read my book again.
 - √ Do you work late nights? Best answer if there is project deadline yes. Do not show that it's your culture to work during nights.
 - √ Any special achievements in your life till now...tell your best project which you have done best in your career.
 - √ Any plans of opening your own software company...Beware do not start pouring your bill gate's dream to him.....can create a wrong impression.

Interview rating Sheet

In the CD we have provided Interview rating excel sheet. This sheet will help you in providing insight of really how much you are ready for JAVA, .NET or SQL Server Interviews. In the sheet we have seven sections:-

- √ Guidelines
- √ JAVA

-
- √ Java results
 - √ .NET
 - √ .NET Results
 - √ SQL Server
 - √ SQL Server results

The guidelines sheet defines the guidelines for the rating. For every question you can give one to five rating. Ratings are rated using the following guidelines :-

- 0-You have no idea about the question
- 1-You know only the definition.
- 2-You know the concept but not the depth of the subject.
- 3-You know the concept and have partial knowledge about the concept.
- 4-You know the concept and have in depth knowledge about the subject. But it's possible that you will stumble in some in depth question.
- 5- You are an expert and no one can touch you in this.

The remaining six sections are questions and results. For instance we have the JAVA sections and the JAVA results section. JAVA section will take in the rating inputs for every questions and JAVA result will show the output. Same hold true for .NET and SQL Server.

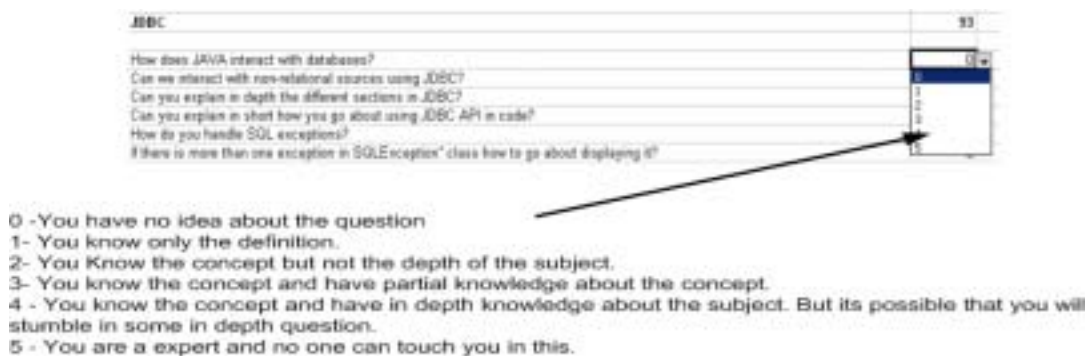

Figure 0.4 : - Choose rating

For every question you need to select ratings.

So go through every question and see how good you are. Definitely you do not have any one to govern you but finally you have to clear the interview so be fair and know your results before hand.

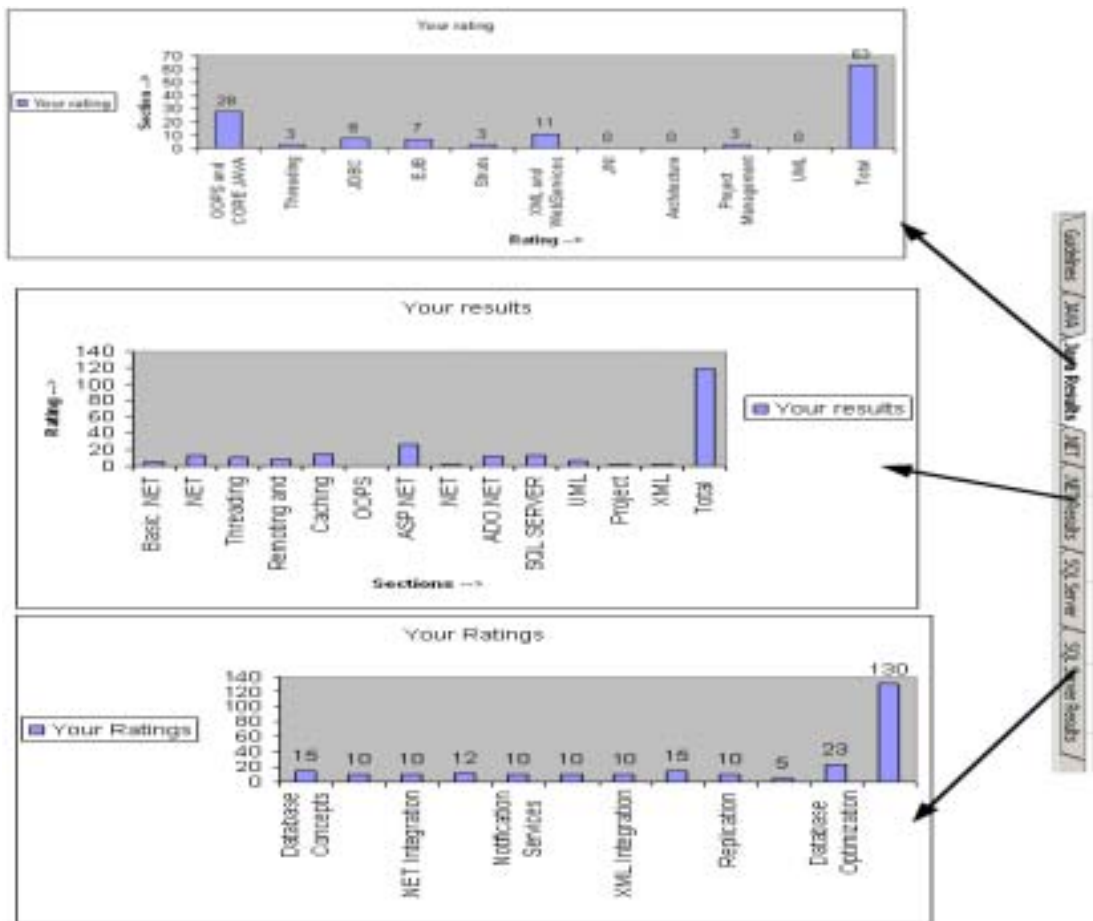

Figure 0.5 : - Rating values

Above is figure shows how you have performed in every section and the overall rating.

1. Basic .NET Framework

(B)What is a IL?

Twist :- What is MSIL or CIL , What is JIT?

(IL)Intermediate Language is also known as MSIL (Microsoft Intermediate Language) or CIL (Common Intermediate Language). All .NET source code is compiled to IL. This IL is then converted to machine code at the point where the software is installed, or at run-time by a Just-In-Time (JIT) compiler.

(B)What is a CLR?

Full form of CLR is Common Language Runtime and it forms the heart of the .NET framework. All Languages have runtime and its the responsibility of the runtime to take care of the code execution of the program. For example VC++ has MSCRT40.DLL,VB6 has MSVBVM60.DLL, Java has Java Virtual Machine etc. Similarly .NET has CLR. Following are the responsibilities of CLR

- √ Garbage Collection :- CLR automatically manages memory thus eliminating memory leaks. When objects are not referred GC automatically releases those memories thus providing efficient memory management.
- √ Code Access Security :- CAS grants rights to program depending on the security configuration of the machine. Example the program has rights to edit or create a new file but the security configuration of machine does not allow the program to delete a file. CAS will take care that the code runs under the environment of machines security configuration.
- √ Code Verification :- This ensures proper code execution and type safety while the code runs. It prevents the source code to perform illegal operation such as accessing invalid memory locations etc.
- √ IL(Intermediate language)-to-native translators and optimizer's :- CLR uses JIT and compiles the IL code to machine code and then executes. CLR also determines depending on platform what is optimized way of running the IL code.

(B)What is a CTS?

In order that two language communicate smoothly CLR has CTS (Common Type System).Example in VB you have "Integer" and in C++ you have "long" these datatypes are not compatible so the interfacing between them is very complicated. In order to able that two different languages can

communicate Microsoft introduced Common Type System. So “Integer” datatype in VB6 and “int” datatype in C++ will convert it to System.int32 which is datatype of CTS. CLS which is covered in the coming question is subset of CTS.

Note: If you have undergone COM programming period interfacing VB6 application with VC++ application was a real pain as the datatype of both languages did not have a common ground where they can come and interface, by having CTS interfacing is smooth.

(B)What is a CLS(Common Language Specification)?

This is a subset of the CTS which all .NET languages are expected to support. It was always a dream of Microsoft to unite all different languages in to one umbrella and CLS is one step towards that. Microsoft has defined CLS which are nothing but guidelines that language to follow so that it can communicate with other .NET languages in a seamless manner.

(B)What is a Managed Code?

Managed code runs inside the environment of CLR i.e. .NET runtime. In short all IL are managed code. But if you are using some third party software example VB6 or VC++ component they are unmanaged code as .NET runtime (CLR) does not have control over the source code execution of the language.

(B)What is a Assembly?

- √ Assembly is unit of deployment like EXE or a DLL.
- √ An assembly consists of one or more files (dlls, exe's, html files etc.), and represents a group of resources, type definitions, and implementations of those types. An assembly may also contain references to other assemblies. These resources, types and references are described in a block of data called a manifest. The manifest is part of the assembly, thus making the assembly self-describing.
- √ An assembly is completely self-describing. An assembly contains metadata information, which is used by the CLR for everything from type checking and security to actually invoking the components methods. As all information is in the assembly itself, it is independent of registry. This is the basic advantage as compared to COM where the version was stored in registry.
- √ Multiple versions can be deployed side by side in different folders. These different versions can execute at the same time without interfering with each other. Assemblies can be private or shared. For private assembly deployment, the assembly is copied to the same directory as the client program that references it. No registration is needed, and no fancy installation program is required.

When the component is removed, no registry cleanup is needed, and no uninstall program is required. Just delete it from the hard drive.

- √ In shared assembly deployment, an assembly is installed in the Global Assembly Cache (or GAC). The GAC contains shared assemblies that are globally accessible to all .NET applications on the machine.

(A) What are the different types of Assembly?

There are two types of assembly Private and Public assembly. A private assembly is normally used by a single application, and is stored in the application's directory, or a sub-directory beneath. A shared assembly is normally stored in the global assembly cache, which is a repository of assemblies maintained by the .NET runtime. Shared assemblies are usually libraries of code which many applications will find useful, e.g. Crystal report classes which will be used by all application for Reports.

(B) What is NameSpace?

Namespace has two basic functionality :-

- √ NameSpace Logically group types, example System.Web.UI logically groups our UI related features.
- √ In Object Oriented world many times its possible that programmers will use the same class name.By qualifying NameSpace with classname this collision can be avoided.

(B) What is Difference between NameSpace and Assembly?

Following are the differences between namespace and assembly :

- √ Assembly is physical grouping of logical units. Namespace logically groups classes.
- √ Namespace can span multiple assembly.

(A)If you want to view a Assembly how do you go about it ?

Twist : What is ILDASM ?

When it comes to understanding of internals nothing can beat ILDASM. ILDASM basically converts the whole exe or dll in to IL code. To run ILDASM you have to go to "C:\Program Files\Microsoft

Visual Studio .NET 2003\SDK\v1.1\Bin". Note that i had v1.1 you have to probably change it depending on the type of framework version you have.

If you run IDASM.EXE from the path you will be popped with the IDASM exe program as shown in figure ILDASM. Click on file and browse to the respective directory for the DLL whose assembly you want to view. After you select the DLL you will be popped with a tree view details of the DLL as shown in figure ILDASM. On double clicking on manifest you will be able to view details of assembly, internal IL code etc as shown in Figure Manifest View.

Note : The version number are in the manifest itself which is defined with the DLL or EXE thus making deployment much easier as compared to COM where the information was stored in registry. Note the version information in Figure Manifest view.

You can expand the tree for detail information regarding the DLL like methods etc.

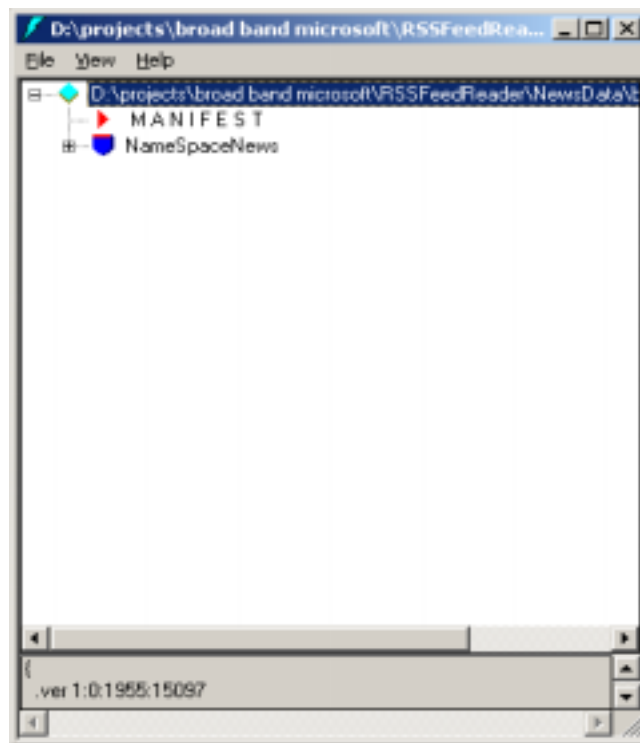
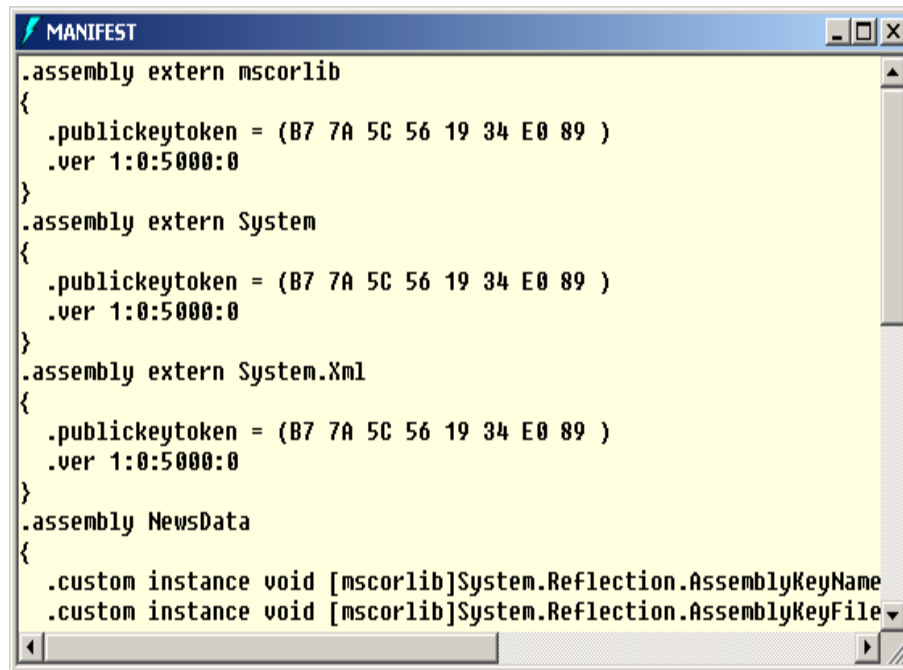

Figure:- 1.1 ILDASM



```
MANIFEST
.assembly extern mscorlib
{
  .publickeytoken = (B7 7A 5C 56 19 34 E0 89 )
  .ver 1:0:5000:0
}
.assembly extern System
{
  .publickeytoken = (B7 7A 5C 56 19 34 E0 89 )
  .ver 1:0:5000:0
}
.assembly extern System.Xml
{
  .publickeytoken = (B7 7A 5C 56 19 34 E0 89 )
  .ver 1:0:5000:0
}
.assembly NewsData
{
  .custom instance void [mscorlib]System.Reflection.AssemblyKeyName
  .custom instance void [mscorlib]System.Reflection.AssemblyKeyFile
```

Figure :- 1.2 Manifest View

(A) What is Manifest?

Assembly metadata is stored in Manifest. Manifest contains all the metadata needed to do the following things (See Figure Manifest View for more details):

- √ Version of assembly
- √ Security identity
- √ Scope of the assembly
- √ Resolve references to resources and classes.
- √ The assembly manifest can be stored in either a PE file (an .exe or .dll) with Microsoft intermediate language (MSIL) code or in a stand-alone PE file that contains only assembly manifest information.

(B)Where is version information stored of an assembly ?

Version information is stored in assembly in manifest.

(I)Is versioning applicable to private assemblies?

Versioning concept is only applicable to global assembly cache (GAC) as private assembly lie in their individual folders.

(B) What is GAC ?

Twist :- What are situations when you register .NET assembly in GAC ?

GAC (Global Assembly Cache) is used where shared .NET assembly reside. GAC is used in the following situations :-

- √ If the application has to be shared among several application.
- √ If the assembly has some special security requirements like only administrators can remove the assembly. If the assembly is private then a simple delete of assembly the assembly file will remove the assembly.

Note :- Registering .NET assembly in GAC can lead to the old problem of DLL hell, where COM version was stored in central registry. So GAC should be used when absolutely necessary.

(I) What is the concept of strong names ?

Twist :- How do we generate strong names ?

Twist :- What is use the of SN.EXE ?

Twist :- How do we apply strong names to assembly?

Twist :- How do you sign an assembly?

Strong name is similar to GUID(It is supposed to be unique in space and time) in COM components.Strong Name is only needed when we need to deploy assembly in GAC. Strong Names helps GAC to differentiate between two versions. Strong names use public key cryptography (PKC) to ensure that no one can spoof it.PKC use public key and private key concept.

Following are the step to generate a strong name and sign a assembly :-

-
- √ Go to “Visual Studio Command Prompt”. See below figure “Visual studio Command Prompt”. Note the samples are compiled in 2005 but 2003 users do not have to worry about it. Same type of command prompt will be seen in 2003 also.

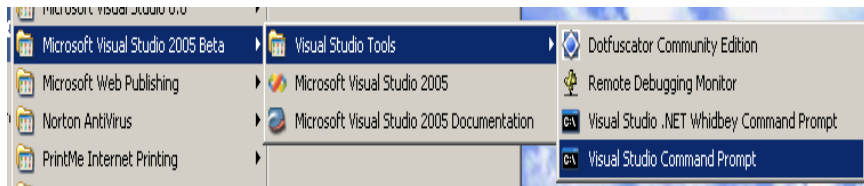

Figure :- 1.3 Visual Studio Command Prompt

- √ After you are in command prompt type `sn.exe -k "c:\test.snk"`.

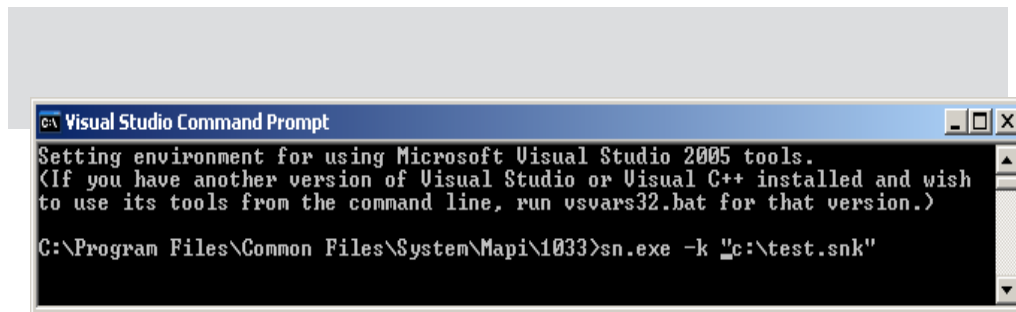
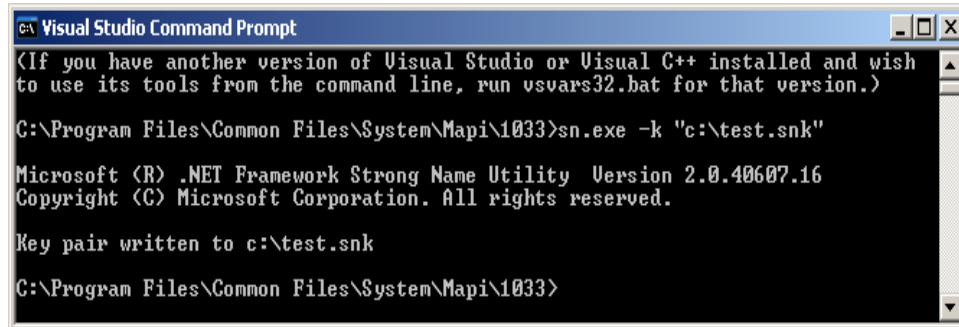

Figure :- 1.4 Running SN.EXE



```
C:\ Visual Studio Command Prompt
<If you have another version of Visual Studio or Visual C++ installed and wish
to use its tools from the command line, run vsvars32.bat for that version.>

C:\Program Files\Common Files\System\Mapi\1033>sn.exe -k "c:\test.snk"

Microsoft (R) .NET Framework Strong Name Utility  Version 2.0.40607.16
Copyright (C) Microsoft Corporation. All rights reserved.

Key pair written to c:\test.snk

C:\Program Files\Common Files\System\Mapi\1033>
```

Figure :- 1.5 Successful output of SN.EXE

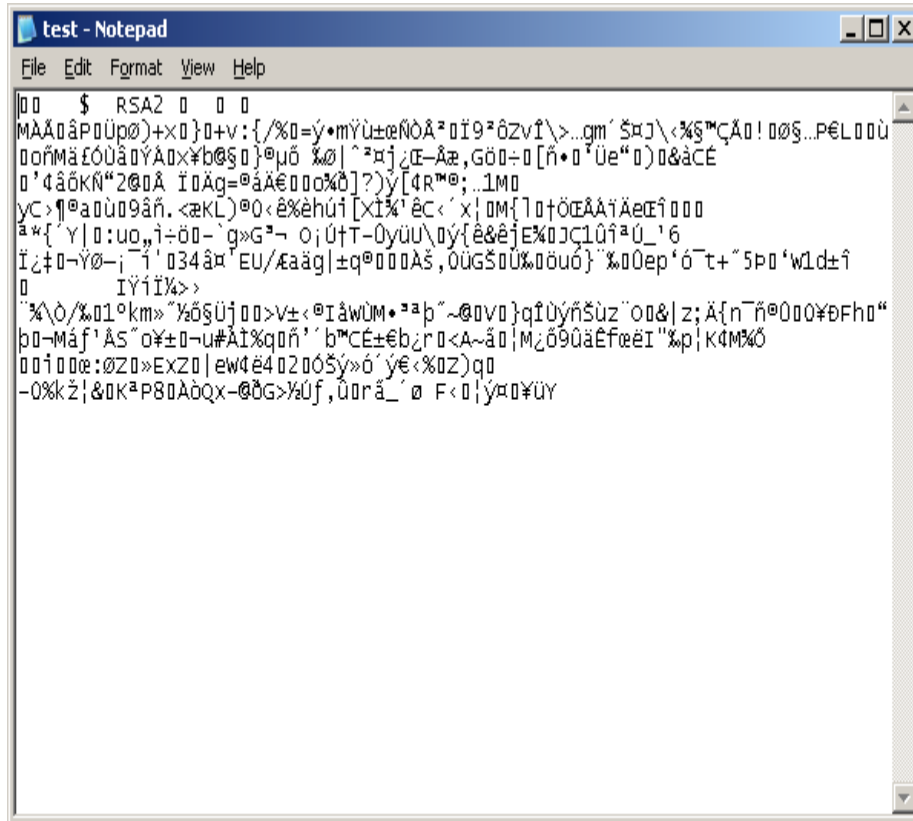

Figure :- 1.6 Sample view of test.snk file

- ✓ After generation of the file you can view the SNK file in a simple notepad.
- ✓ After the SNK file is generated its time to sign the project with this SNK file.

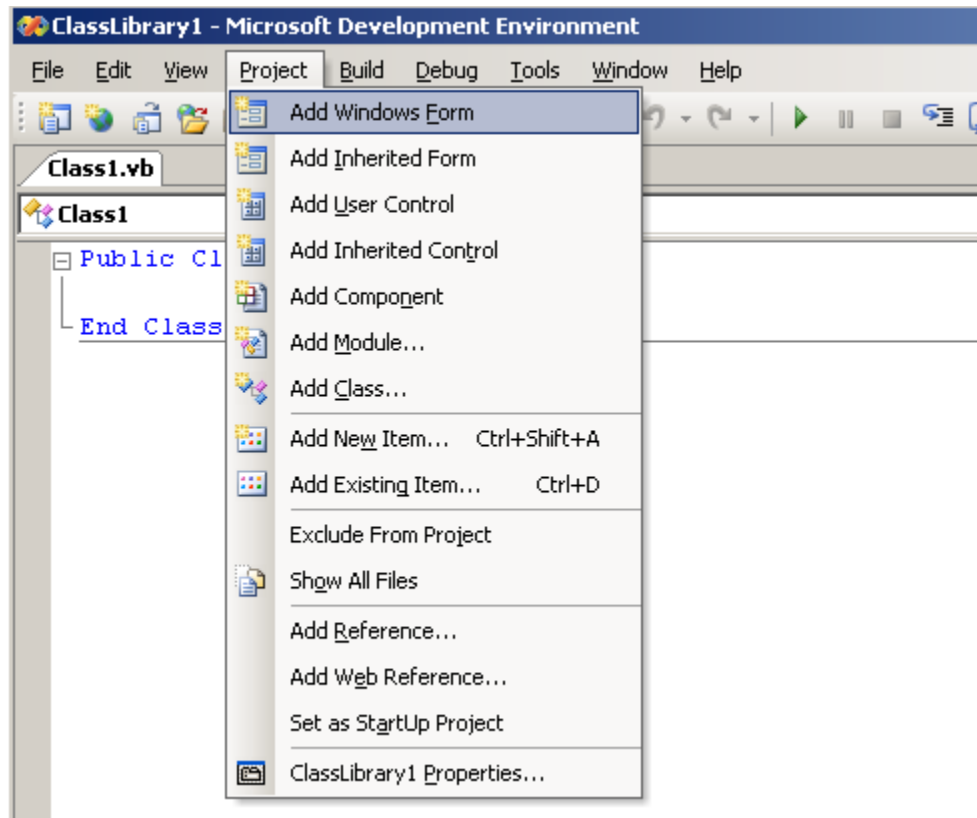

Figure:- 1.7 Click on project and then click on “classlibrary1 properties” menu to sign the assembly

- √ Click on project -- properties and the browse the SNK file to the respective folder and compile the project.

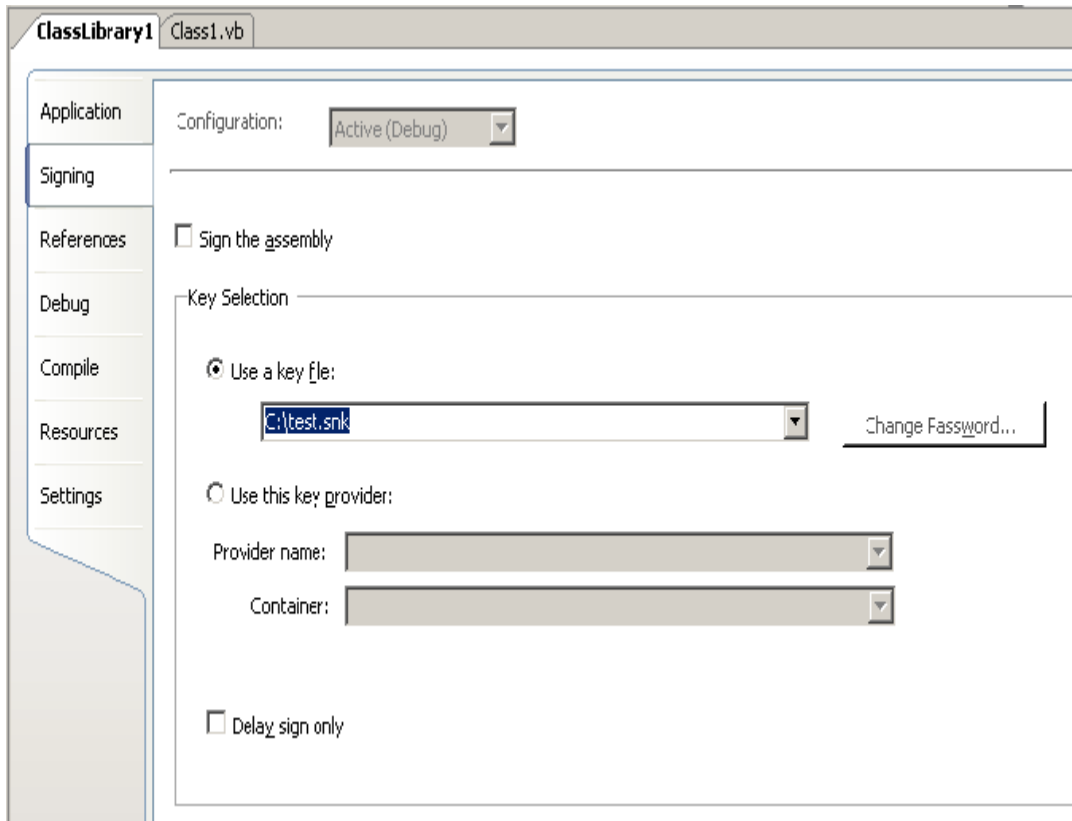

Figure :- 1.8 Click on Use a key file to sign the assembly with strong name

(I)How to add and remove an assembly from GAC?

There are two ways to install .NET assembly in GAC:-

- √ Using Microsoft Installer Package. You can get download of installer from <http://www.microsoft.com>.
- √ Using Gacutil. Goto “Visual Studio Command Prompt” and type “gacutil -i (assembly_name)”, where (assembly_name) is the DLL name of the project.

(B) What is Delay signing ?

During development process you will need strong name keys to be exposed to developer which is not a good practice from security aspect point of view. In such situations you can assign the key later on and during development you can use delay signing.

Following is process to delay sign an assembly:

- √ First obtain your string name keys using SN.EXE.
- √ Annotate the source code for the assembly with two custom attributes from System.Reflection: `AssemblyKeyFileAttribute`, which passes the name of the file containing the public key as a parameter to its constructor. `AssemblyDelaySignAttribute`, which indicates that delay signing, is being used by passing true as a parameter to its constructor. For example as shown below:

[Visual Basic]

```
<Assembly:AssemblyKeyFileAttribute("myKey.snk")>
```

```
<Assembly:AssemblyDelaySignAttribute(true)>
```

[C#]

```
[assembly:AssemblyKeyFileAttribute("myKey.snk")]
```

```
[assembly:AssemblyDelaySignAttribute(true)]
```

The compiler inserts the public key into the assembly manifest and reserves space in the PE file for the full strong name signature. The real public key must be stored while the assembly is built so that other assemblies that reference this assembly can obtain the key to store in their own assembly reference.

- √ Because the assembly does not have a valid strong name signature, the verification of that signature must be turned off. You can do this by using the `-Vr` option with the Strong Name tool. The following example turns off verification for an assembly called `myAssembly.dll`.

```
Sn -Vr myAssembly.dll
```

√ Just before shipping, you submit the assembly to your organization's signing authority for the actual strong name signing using the `-R` option with the Strong Name tool. The following example signs an assembly called `myAssembly.dll` with a strong name using the `sgKey.snk` key pair.

```
Sn -R myAssembly.dll sgKey.snk
```

(B)What is garbage collection?

Garbage collection is a CLR feature which automatically manages memory. Programmers forget to release the objects while coding Laziness (Remember in VB6 where one of the good practices is to set object to nothing). CLR automatically releases objects when they are no longer in use and referenced. CLR runs on non-deterministic to see the unused objects and cleans them. One side effect of this non-deterministic feature is that we cannot assume an object is destroyed when it goes out of the scope of a function. we should avoid using destructors because before GC destroys the object it first executes destructor in that case it will have to wait for code to release the unmanaged resource. result in additional delays in GC. So its recommended to implement `IDisposable` interface and write cleanup code in `Dispose` method and call `GC.SuppressFinalize` method so instructing GC not to call your constructor. For more details read Why is it preferred to not use `finalize` for clean up? in OOPS chapter..

(I) Can we force garbage collector to run ?

`System.GC.Collect()` forces garbage collector to run. This is not recommended but can be used if situations arises.

(B)What is reflection?

All .NET assemblies have metadata information stored about the types defined in modules. This metadata information can be accessed by mechanism called as "Reflection". `System.Reflection` can be used to browse through the metadata information.

Using reflection you can also dynamically invoke methods using `System.Type.InvokeMember`. Below is sample source code if needed you can also get this code from CD provided, go to "Source code" folder in "Reflection Sample" folder.

```
Public Class Form1
    Private Sub Form1_Load(ByVal sender As System.Object, ByVal e As
System.EventArgs) Handles MyBase.Load
        Dim Pobjtype As Type
        Dim PobjObject As Object
        Dim PobjButtons As New Windows.Forms.Button()
        Pobjtype = PobjButtons.GetType()
```

```

For Each PobjObject In Pobjtype.GetMembers
    LstDisplay.Items.Add(PobjObject.ToString())
Next
End Sub
End Class

```

Note :- Sample source code are compiled using VB.NET 2005.

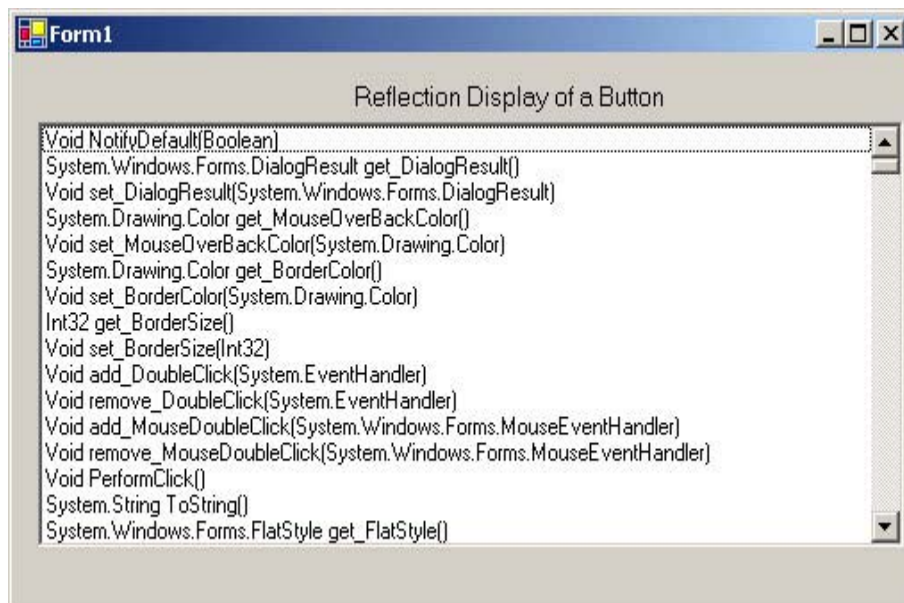

Figure:- 1.9 Sample reflection display

Sample source code uses reflection to browse through “Button” class of “Windows.Forms”. If you compile and run the program following is output as shown in “Sample Reflection Display”. Using reflection you can also dynamically invoke a method using “System.Type.InvokeMember”.

Note :- System.Type.InvokeMember is left as homework for readers. Believe me you will enjoy doing it yourself and the concept of reflection will be clearer.

(P)What are different types of JIT ?

Note :- This question can only be asked when the interviewer does not know what he wants. It was asked to me in one of interview and for 15 minutes he was roaming around the

same question in order to get answer from me (requirement was for a simple database project). Beware of such companies and interviewers you can land up no where.

JIT compiler is a part of the runtime execution environment.

In Microsoft .NET there are three types of JIT compilers:

- √ Pre-JIT :- Pre-JIT compiles complete source code into native code in a single compilation cycle. This is done at the time of deployment of the application.
- √ Econo-JIT :- Econo-JIT compiles only those methods that are called at runtime. However, these compiled methods are removed when they are not required.
- √ Normal-JIT :- Normal-JIT compiles only those methods that are called at runtime. These methods are compiled the first time they are called, and then they are stored in cache. When the same methods are called again, the compiled code from cache is used for execution.

(B) What are Value types and Reference types ?

Value types directly contain their data which are either allocated on the stack or allocated in-line in a structure.

Reference types store a reference to the value's memory address, and are allocated on the heap. Reference types can be self-describing types, pointer types, or interface types.

Variables that are value types each have their own copy of the data, and therefore operations on one variable do not affect other variables. Variables that are reference types can refer to the same object; therefore, operations on one variable can affect the same object referred to by another variable. All types derive from the System.Object base type.

(B) What is concept of Boxing and Unboxing ?

Boxing permits any value type to be implicitly converted to type object or to any interface type implemented by value type. Boxing is a process in which object instances are created and copy values in to that instance.

Unboxing is vice versa of boxing operation where the value is copied from the instance in to appropriate storage location.

Below is sample code of boxing and unboxing where integer data type is converted in to object and then vice versa.

Dim x As Integer

Dim y As Object

x = 10

' boxing process

y = x

' unboxing process

x = y

(B) What is the difference between VB.NET and C# ?

Well this is the most debatable issue in .NET community and people treat there languages like religion. Its a subjective matter which language is best. Some like VB.NET's natural style and some like professional and terse C# syntaxes. Both use the same framework and speed is also very much equivalents. But still let's list down some major differences between them :-

Advantages VB.NET :-

- √ Has support for optional parameters which makes COM interoperability much easy.
- √ With Option Strict off late binding is supported. Legacy VB functionalities can be used by using Microsoft.VisualBasic namespace.
- √ Has the WITH construct which is not in C#.
- √ The VB.NET part of Visual Studio .NET compiles your code in the background. While this is considered an advantage for small projects, people creating very large projects have found that the IDE slows down considerably as the project gets larger.

Advantages of C#

- √ XML documentation is generated from source code but this is now been incorporated in Whidbey.
- √ Operator overloading which is not in current VB.NET but is been introduced in Whidbey.
- √ Use of this statement makes unmanaged resource disposal simple.
- √ Access to Unsafe code. This allows pointer arithmetic etc, and can improve performance in some situations. However, it is not to be used lightly, as a lot of the normal safety of C# is lost (as the name implies). This is the major difference that you can access unmanaged code in C# and not in VB.NET.

** How much ever this book tries it can not match the huge variations of questions that have been asked in.NET interviews.But note there will be variations and they will map to some question of this book.*

(I)What is the difference between System exceptions and Application exceptions?

All exception derives from Exception Base class. Exceptions can be generated programmatically or can be generated by system. Application Exception serves as the base class for all application-specific exception classes. It derives from Exception but does not provide any extended functionality. You should derive your custom application exceptions from Application Exception.

Application exception is used when we want to define user defined exception, while system exception is all which is defined by .NET.

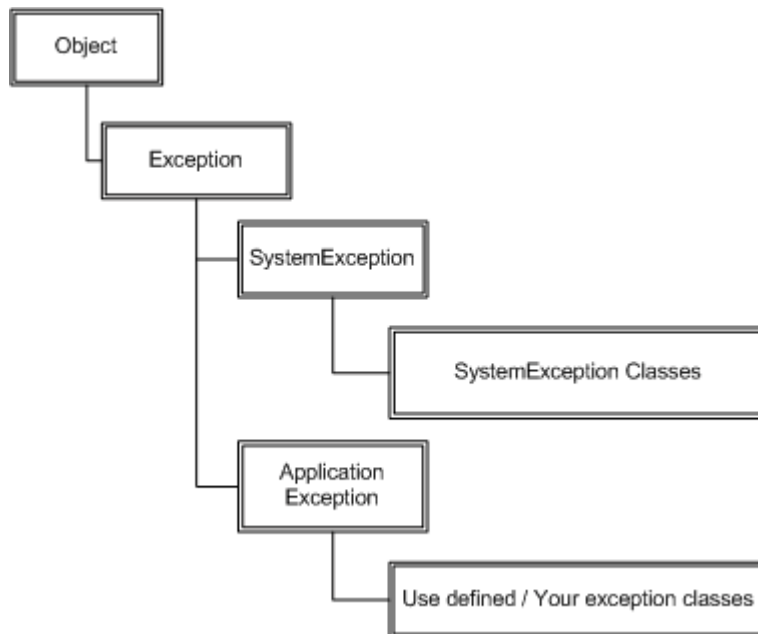

Figure :- 1.10 Exception Hierarchy

Note:- Frankly I have always relied on using Microsoft exception application blocks. As such I have never used application exception; I think most of the work is done using System exception classes.

(I)What is CODE Access security?

CAS is part of .NET security model that determines whether or not a piece of code is allowed to run and what resources it can use while running. Example CAS will allow an application to read but not to write and delete a file or a resource from a folder..

(I)What is a satellite assembly?

Refer Localization chapter for more details

(A)How to prevent my .NET DLL to be decompiled?

By design .NET embeds rich Meta data inside the executable code using MSIL. Any one can easily decompile your DLL back using tools like ILDASM (owned by Microsoft) or Reflector for .NET which is a third party. Secondly there are many third party tools which make this decompiling process a click away. So any one can easily look in to your assemblies and reverse engineer them back in to actual source code and understand some real good logic which can make it easy to crack your application.

The process by which you can stop this reverse engineering is using “obfuscation”. It’s a technique which will foil the decompilers. There are many third parties (XenoCode, Demeanor for .NET) which provide .NET obfuscation solution. Microsoft includes one that is Dotfuscator Community Edition with Visual Studio.NET.

Note - I leave this as homework to reader’s compile, a DLL obfuscate it using “Dotfuscator Community Edition” which comes with Visual Studio.NET and try viewing the same using ILDASM.

(I) What is the difference between Convert.ToString and .ToString() method ?

Just to give an understanding of what the above question means see the below code.

```
int i =0;  
MessageBox.Show(i.ToString());  
MessageBox.Show(Convert.ToString(i));
```

We can convert the integer “i” using “i.ToString()” or “Convert.ToString” so what’s the difference. The basic difference between them is “Convert” function handles NULLS while “i.ToString()” does not it will throw a NULL reference exception error. So as good coding practice using “convert” is always safe.

(A) What is Native Image Generator (Ngen.exe)?

The Native Image Generator utility (Ngen.exe) allows you to run the JIT compiler on your assembly's MSIL and generate native machine code which is cached to disk. After the image is created .NET runtime will use the image to run the code rather than from the hard disk. Running Ngen.exe on an assembly potentially allows the assembly to load and execute faster, because it restores code and data structures from the native image cache rather than generating them dynamically.

Below are some points to be remembered for Native Image Generator:-

- √ Native images load faster than MSIL because JIT compilation and type-safety verification is eliminated.
- √ If you are sharing code between process Ngen.exe improves the performance significantly. As Native image generated Windows PE file so a single DLL file can be shared across applications. By contrast JIT produced code are private to an assembly and can not be shared.
- √ Native images enable code sharing between processes.
- √ Native images require more storage space and more time to generate.
- √ Startup time performance improves lot. We can get considerable gains when applications share component assemblies because after the first application has been started the shared components are already loaded for subsequent applications. If assemblies in an application must be loaded from the hard disk, does not benefit as much from native images because the hard disk access time shadows everything.
- √ Assemblies in GAC do not benefit from Native image generator as the loader performs extra validation on the strong named assemblies thus shadowing the benefits of Native Image Generator.
- √ If any of the assemblies change then Native image should also be updated.
- √ You should have administrative privilege for running Ngen.exe.
- √ While this can fasten your application startup times as the code is statically compiled but it can be somewhat slower than the code generated dynamically by the JIT compiler. So you need to compare how the whole application performance with Ngen.exe and with out it.

To run Ngen.exe, use the following command line.

ngen.exe install <assemblyname>

This will synchronously precompile the specified assembly and all of its dependencies. The generated native images are stored in the native image cache.

In .NET Framework 2.0 there is a service (.NET Runtime Optimization Service) which can precompile managed assemblies in the background. You can schedule your assemblies to be precompiled asynchronously by queueing them up with the NGEN Service. Use the following command line.

ngen.exe install <assemblyname> /queue:<priority>

Assemblies which are critical to your application's start up time should either be precompiled synchronously or asynchronously with priority 1. Priority 1 and 2 assemblies are precompiled aggressively while Priority 3 assemblies are only precompiled during machine idle-time. Synchronously precompiling your critical assemblies guarantees that the native images will be available prior to the first time your end user launches the application but increases the time taken to run your application's set up program.

You can uninstall an assembly and its dependencies (if no other assemblies are dependent on them) from the native image cache by running the following command.

ngen.exe uninstall <assemblyname>

Native images created using Ngen.exe cannot be deployed; instead they need to be created on the end user's machine. These commands therefore need to be issued as part of the application's setup program. Visual Studio .NET can be used to implement this behavior by defining custom actions in a Microsoft Installer (MSI) package.

Note: - One of the things the interviewer will expect to be answered is what scenario will use a Native Image generator. Best is to say that we first need to test the application performance with Native Image and with out it and then make a decision.

(A) If we have two version of same assembly in GAC how do we make a choice ?

Note: - I really want to explain this in depth for two reasons. First I have seen this question been frequently asked and second it's of real practical importance. I have faced this in every of my .NET projects...So let's try to get this fundamental not in our brain but in our heart.Thanks Zeeshan Khan (it_zeeshanlko@yahoo.com) to correct me regarding some corrections in this question.

OK first let's try to understand what the interviewer is talking about. Let's say you have made an application and its using a DLL which is present in GAC. Now for some reason you make second version of the same DLL and put it in GAC. Now which DLL does the application refer? Ok by default it always uses the version by which you have compiled you application in IDE. But you want that it should actually use the older version.

So first we answer in short. You need to specify "bindingRedirect" in your config file. For instance in the below case "ClassLibraryVersion" has two versions "1.1.1830.10493" and "1.0.1830.10461" from which "1.1.1830.10493" is the recent version. But using the bindingRedirect we can specify saying "1.0.1830.10461" is the new version. So the client will not use "1.1.1830.10493".

```
<configuration>
  <runtime>
    <assemblyBinding xmlns="urn:schemas-microsoft-com:asm.v1">
      <dependentAssembly>
        <assemblyIdentity name="ClassLibraryVersion"
          publicKeyToken="b035c4774706cc72"
          culture="neutral"/>
        <bindingRedirect oldVersion="1.1.1830.10493"
          newVersion="1.0.1830.10461"/>
      </dependentAssembly>
    </assemblyBinding>
  </runtime>
</configuration>
```

Ok now I will try to answer it in long way by doing a small sample project. Again this project will be done using C#. So in CD you can find the "Versioning" project. Below is the solution display, it has two projects one the windows client project ("WindowsVersioningCSharp") and second the class library project ("ClassLibraryVersion") which will be installed in GAC with two versions.

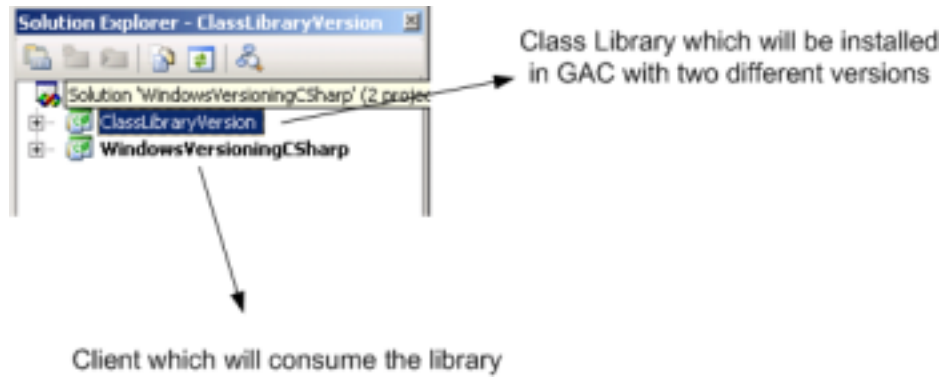

Figure 1.11: - Solution files for the versioning project.

Our first primary goal is to put two different versions of the same DLL in GAC. So let's make a walk through of "ClassLibraryVersion" project. It's a very simple class which has "Version" function which just sends a string "This is old Version". Second we will also just ensure that the assembly version is "1.0" in the "AssemblyInfo.cs".

```

namespace ClassLibraryVersion
{
    public class Class1
    {
        public Class1()
        {
        }
        public string Version()
        {
            return "This is old version";
        }
    }
}

[assembly: AssemblyProduct("WindowsVe
[assembly: AssemblyCopyright("Copyriq
[assembly: AssemblyTrademark("")]
[assembly: AssemblyCulture("")]

// Version information for an assembl
//
// Major Version
// Minor Version
// Build Number
// Revision
//
// You can specify all the values or
// by using the '*' as shown below:
[assembly: AssemblyVersion("1.0.*")]

```

Version 1.0 returns the following data.

Assembly.info version number

Figure 1.12 : - Assembly Version 1.0

Second in order that we can put a DLL in GAC we need to create generate strong names and assign the same to the class. For instance, in below figure I have generated the strong name in "mykey.snk" and assigned the same to the DLL.

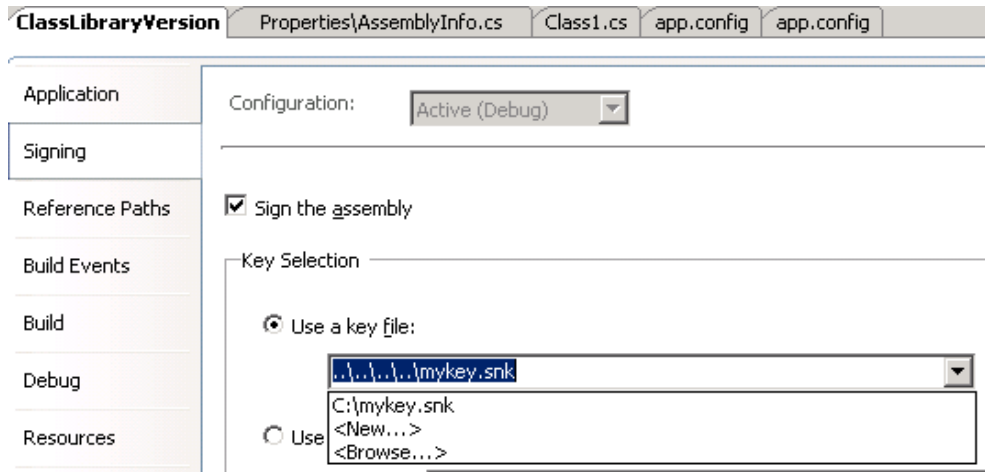

Figure 1.13 : - Strong naming your DLL

Finally we need to install the same in GAC using “gacutil” tool. Below is the figure which shows the same. This installs one version of “ClassLibraryVersion.dll” in GAC.

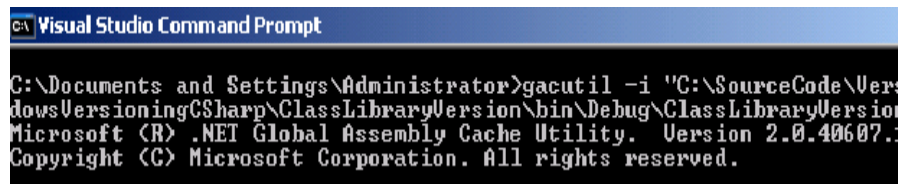

Figure 1.14 : - Install the same in GAC

Now it is time to create a second version of the DLL. So here is what we will do first we will just return a different string value for this new version DLL. You can see in the below figure I have changed the string to return “This is New Version”. Secondly we also need to change the AssemblyVersion to “1.1.*” in the “AssemblyInfo.cs” file. After that again compile the DLL and run the “gacutil” to register this second version of the “ClassLibraryVersion.dll”.

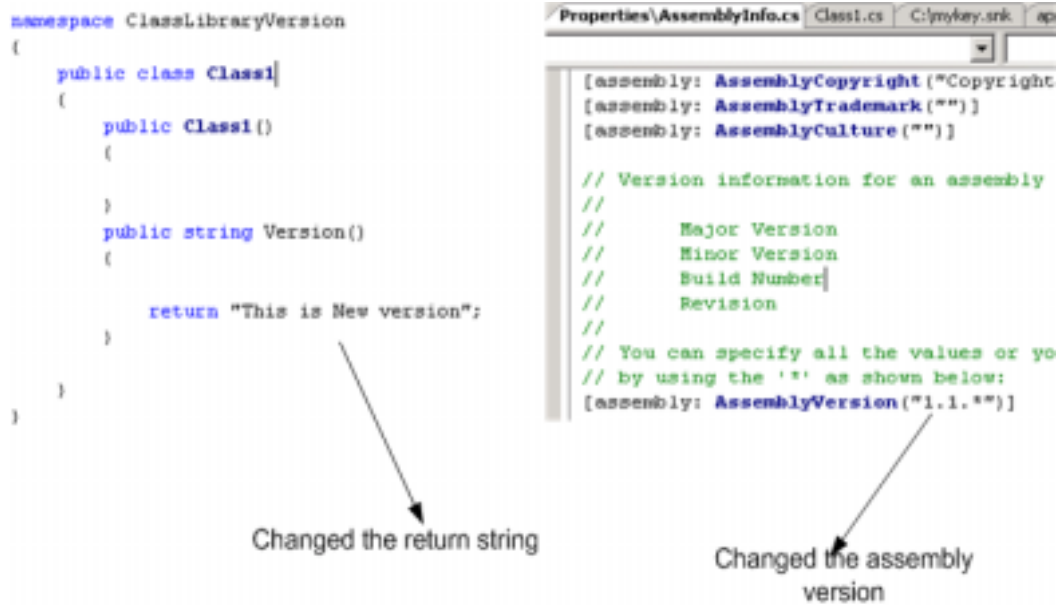

Figure 1.15 : - Rename to Assembly Version 1.1

Now when we view the GAC we can see two version of “ClassLibraryVersion” i.e. “1.1.1832.2619” and “1.0.1832.2172” (see figure below).

Assembly Name	Version
Accessibility	1.0.5000.0
Accessibility	2.0.3600.0
ADODB	7.0.3300.0
apphost	2.0.3600.0
AspNetMMCExt	2.0.3600.0
ClassLibraryVersion	1.1.1832.2619
ClassLibraryVersion	1.0.1832.2172
CppCodeProvider	8.0.1200.0
Microsoft.VisualBasic	8.0.3500.0

Figure 1.16 : - Two version of “ClassLibraryVersion” dll.

Now that we have created the environment of two version of the same DLL in GAC its time to look at how client can make a choice between those versions. We need to generate “publicKeyToken” in order to move ahead. Below is a sample print screen which shows how we can use “sn.exe” to generated the public key token. Note the “-T” parameter.

```

s and Settings\Administrator>sn -T "C:\SourceCode\Versioning\Win
harp\ClassLibraryVersion\bin\Debug\ClassLibraryVersion.dll"

R> .NET Framework Strong Name Utility Version 2.0.40607.16
C> Microsoft Corporation. All rights reserved.

token is b035c4774706cc72

```

Figure 1.17 : - Get the PublicKeyToken

Now let’s look at the client which will consume this DLL. I have just added windows form and a button to the same. In the button click we will try to call the version function and display the data. So below is the code in the first step we create the object of “ClassLibraryVersion.Class1” and in the second step we call the “Version” function to display the data.

```

private void button1_Click(object sender, EventArgs e)
{
    ClassLibraryVersion.Class1 objclass1 = new ClassLibraryVersion.Class1
    MessageBox.Show(objclass1.Version());
}

```

Figure 1.18 : - Client code calling the GAC class.

Now comes the most important part of the whole thing the “app.config” file which will decide which version should be used. So add a new “app.config” file in the project and add the “AssemblyBinding” section as show below. So you need to specify the following things:-

- √ Assembly name in the “name” attribute of “assemblyIdentity” section.
- √ Specify the “publicKeyToken” value in the “assemblyIdentity” section which was generated using “sn.exe -T ‘dllname.dll’ “.
- √ Specify the “oldVersion” and “newVersion” values in the “bindingRedirect” element. So what ever version we want the client to use should be specified in the “newVersion” attribute.

You can see from the figure below I have specified that client should use “1.0.*” version. So the client will display “This is old Version”.



Figure 1.19 : - App.config file using the BindingRedirect

If you run the source code with changing version numbers you can see the below two message boxes on different version numbers. “This is old version” will be displayed when “newVersion” value is “1.0.1832.5411” and “This is new Version” will be displayed when “newVersion” value is “1.1.1832.5427”.

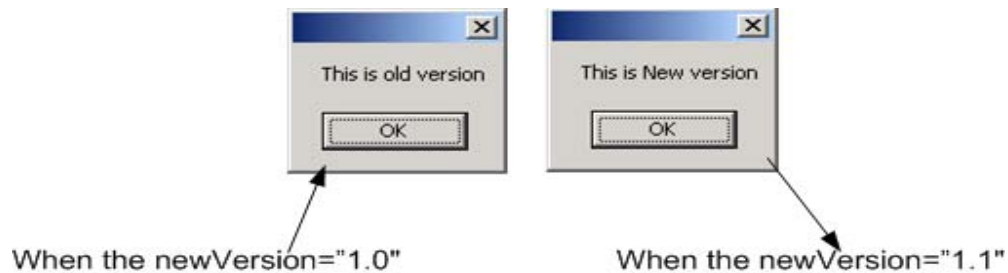

Figure 1.20 : - Different Display depending on version numbers

Note: - Source code is provided in “versioning” folder. But as you compile the DLL’s different publicToken numbers are created so you need to run the sn.exe in your machine and change the token number accordingly in the “App.config” file.

(A)What is CodeDom?

“CodeDom” is an object model which represents actually a source code. It is designed to be language independent - once you create a “CodeDom” hierarchy for a program we can then generate the source code in any .NET compliant language. So let’s try to do something real practical and simple to just get a feel of how powerful “CodeDom” is.

Note :- You can get the source code in CD in “CodeDom” folder.

We will try to generate the following code below. The below code which will be generated does not do anything special buy just displays a hello message and waits for the key to be pressed.

```
namespace InterviewQuestions  
{  
using System;  
public class EntryPoint  
{  
public static void Main()  
{  
System.Console.WriteLine(“Hello from Interview Question series”);  
System.Console.ReadLine();
```

```
}  
}  
}
```

The “Codedom” folder in the CD has one “GenerateCode” method which returns “CodeCompileUnit” object. “CodeDom” is nothing but a full DOM model where every object in the structure represents a code unit. I have put comments the code so that the code is self understandable. I have commented the code below so that readers can follow what is exactly happening. When you click the button it generates the “MyCode.cs” and also compiles the “Mycode.exe” in the “bin” folder.

```
private CodeCompileUnit GenerateCode()  
{  
// Definition of the Main method which will be entry point  
CodeEntryPointMethod objMainMethod = new CodeEntryPointMethod();  
objMainMethod.Name = “Main”;  
  
// generate this expression: Console  
CodeTypeReferenceExpression consoleType = new CodeTypeReferenceExpression();  
consoleType.Type = new CodeTypeReference(typeof(Console));  
  
// Set up the argument list to pass to Console.WriteLine()  
CodeExpression[] writeLineArgs = new CodeExpression[1];  
CodePrimitiveExpression arg0 = new CodePrimitiveExpression(“Hello from Interview  
Question series”);  
writeLineArgs[0] = arg0;  
  
// generate this statement: Console.WriteLine(message)  
CodeMethodReferenceExpression writeLineRef = new  
CodeMethodReferenceExpression(consoleType, “WriteLine”);
```

```
CodeMethodInvokeExpression writeLine = new  
CodeMethodInvokeExpression(writeLineRef, writeLineArgs);  
  
// generate this statement: Console.ReadLine()  
CodeMethodReferenceExpression readLineRef = new  
CodeMethodReferenceExpression(consoleType, "ReadLine");  
CodeMethodInvokeExpression readLine = new  
CodeMethodInvokeExpression(readLineRef);  
  
// Add Main() method to a class  
CodeTypeDeclaration theClass = new CodeTypeDeclaration();  
theClass.Members.Add(objMainMethod);  
theClass.Name = "EntryPoint";  
  
// Add both the code of WriteLine and Readline  
objMainMethod.Statements.Add(writeLine);  
objMainMethod.Statements.Add(readLine);  
  
// Add namespace and add class  
CodeNamespace ns = new CodeNamespace("InterviewQuestions");  
ns.Imports.Add(new CodeNamespaceImport("System"));  
ns.Types.Add(theClass);  
  
// Generate the Compile Unit  
CodeCompileUnit unit = new CodeCompileUnit();  
unit.Namespaces.Add(ns);
```

Sample provided is very basic but in actual project using codedom can be very complicated. Projects where you need auto code generation codedom can be a right choice. Beware of high bulky architecture created due to codedom.

2..NET Interoperability

(I) How can we use COM Components in .NET?

Twist : What is RCW ?

.NET components communicate with COM using RCW (Runtime Callable Wrapper). Following are the ways with which you can generate RCW :-

- √ Adding reference in Visual Studio.net. See figure below (Adding reference using VS.NET 2005). Wrapper class is generated and placed in the "BIN" directory.

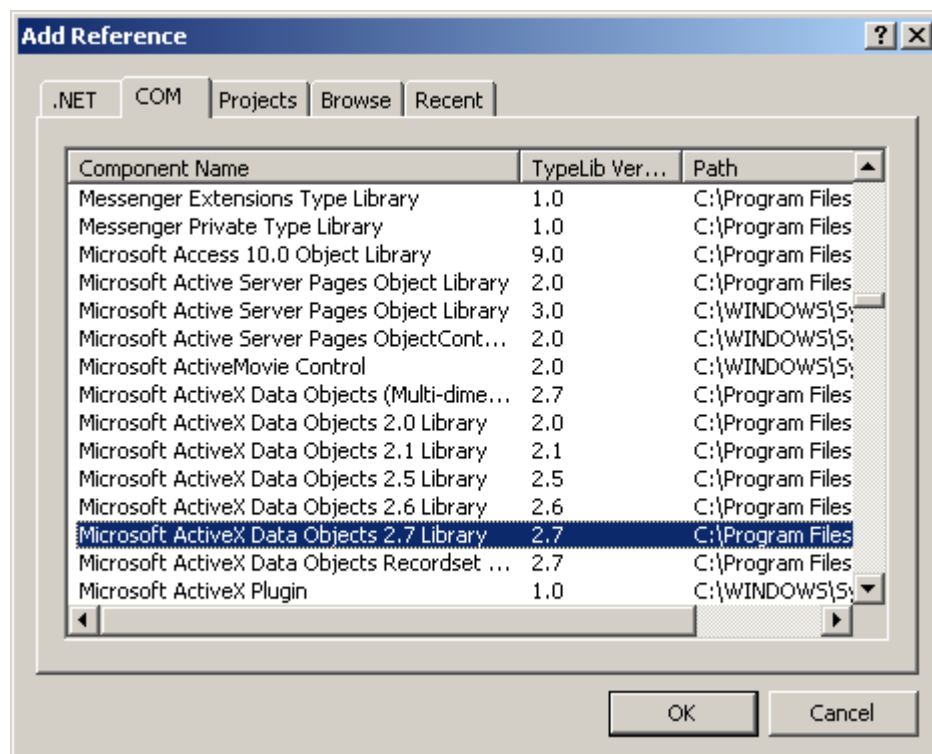

Figure :- 2.1 Adding Reference using VS.NET 2005

-
- √ Using Type library import tool. Tlbimp.exe yourname.dll.
 - √ Using interop services. System.runtime.InteropServices namespace contains class TypeLib Converter which provides methods to convert COM classes and interface in to assembly metadata.
 - √ Make your custom wrappers. If your COM component does not have type library then the only way to communicate is writing custom wrappers. That means communicating directly with COM components.

(I) Once I have developed the COM wrapper do I have to still register the COM in registry?

Yes.

(A) How can we use .NET components in COM?

Twist :- What is CCW (COM callable wrapper) ?

Twist :- How do we ensure that .NET components is compatible with COM ?

.NET components can not be used in straight forward way with COM. You will need to create CCW in order that COM components communicate with .NET assemblies. Following are the different approaches to implement it :-

- √ Explicitly declare interfaces..

```
Public Interface ICustomer
    Property CustomerName() As String
    Property CustomerCode() As String
    Sub AddCustomer()
End Interface
Public Class Customer
    Implements ICustomer
    Private PstrCustomerName As String
    Private PstrCustomerCode As String

    Public Sub AddCustomer() Implements ICustomer.AddCustomer
        Try
            ` addin of database code can go here
        Catch ex As Exception
            Throw ex
        End Try
    End Sub
End Class
```

```

End Sub

Public Property CustomerCode() As String Implements
ICustomer.CustomerCode
    Get
        Return PstrCustomerCode
    End Get
    Set(ByVal value As String)
        PstrCustomerCode = value
    End Set
End Property

Public Property CustomerName() As String Implements
ICustomer.CustomerName
    Get
        Return PstrCustomerName
    End Get
    Set(ByVal value As String)
        PstrCustomerName = value
    End Set
End Property

Public Sub New()

End Sub
End Class

```

Note :- Source code of this is provided in CD in SOURCECODE folder in COMCALLABLEWRAPPER

The above customer class is going to be used by COM components so all the properties and methods are declared in interface and implemented in the customer class. Customer Name.Customer Code and AddCustomer are first declared in ICustomer and then implemented in Customer Class. Also note that the class must have a default constructor.

Note :- All source code in this book is provided in VB.NET that does not mean that author of the book does not like C#. In fact the main programming language of author is C#. In order to keep things small I have only used one language. But the conversion is so seamless that it is of least matter.

√ The second way to create CCW is by using InteropServices attributes. Here interfaces are created automatically.

Following are different type of class attributes :

None:-No class interface is generated for the class. This is default setting when you do not specify anything

AutoDispatch :- Interface that supports IDispatch is created for the class. However, no type information is produced.

AutoDual :- A dual interface is created for the class. Type information is produced and made available in the type library.

Below in the source code we have used the third attribute.

```
Imports System.Runtime.InteropServices
<ClassInterfaceAttribute(ClassInterfaceType.AutoDual)> _
Public Class ClsCompliant

End Class
```

Other than class attributes defined up there are other attributes with which you can govern other part of assembly. Example “GuidAttribute” allows you to specify the GUID, “ComVisibleAttribute” can be used to hide .NET types from COM etc. All attributes are not in scope of the book as this is a interview questions book refer MSDN for more details.

√ Once .NET assembly is created using either interface or using interopservices method we need to create a COM type library using Type library export tool.

Tlbexp (AssemblyName)

√ The final thing is registering the CCW in registry using regasm tool.

regasm AssemblyName [Options]

√ Finally refer the TLB in your COM IDE Below is figure showing VB6 IDE referencing the DLL

Note :- DLL and TLB should be in same directory where the application is executed.

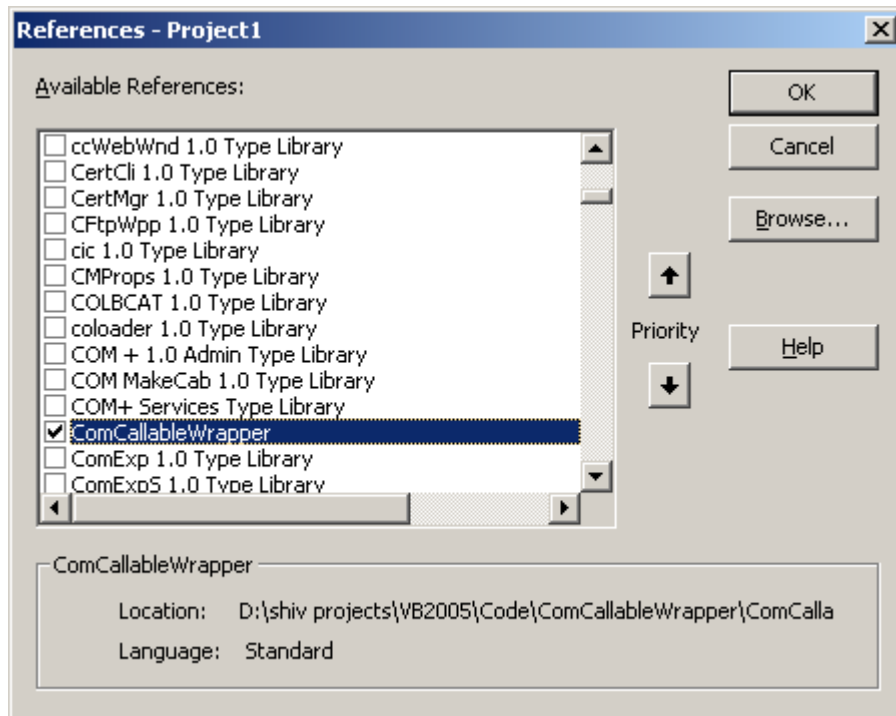

Figure :- 2.2 VB6 IDE referencing the CCW

(A)How can we make Windows API calls in .NET?

Windows API call are not COM based and they are invoked through Platform Invoke Services.

*Declare StringConversionType (Function / Sub) MethodName Lib "DllName" ([Args])
As Type*

- √ strings StringConversionType is for what type of conversion should take place. Either we can specify Unicode to convert all strings to Unicode values, or Auto to convert according to the .NET runtime rules.
- √ MethodName is the name of the API to call.
- √ DllName is the name of the DLL.
- √ Args are any arguments to the API call.

√ Type is the return type of the API call.

Below is a sample code for VB.NET which uses Sleep windows API for delaying.

```
Public Class Form1
    Declare Auto Sub Sleep Lib "kernel32.dll" (ByVal dwMilliseconds
As Long)
    Private Sub Form1_Load(ByVal sender As System.Object, ByVal e As
System.EventArgs) Handles MyBase.Load
        MessageBox.Show(" start sleeping for 5000 Milli
seconds.....")
        Sleep(5000)
        MessageBox.Show(" end of sleeping.....")
    End Sub
End Class
```

Note:- Source code is provided in CD in "APICALL" folder

In VB.NET we use declare keyword but in C# it goes little bit different, we use DLLIMPORT here.

Note :- We have interopservices in this and EXTERN keyword.

```
#region Using directives

using System;
using System.Collections.Generic;
using System.ComponentModel;
using System.Data;
using System.Drawing;
using System.Windows.Forms;
using System.Runtime.InteropServices;
#endregion

namespace CSharpCode
{
    partial class Form1 : Form
    {
        [DllImport("Kernel32.dll")]
        static extern int Sleep(long dwMilliseconds);
        public Form1()
        {
            InitializeComponent();
        }

        private void Form1_Load(object sender, EventArgs e)
```

```

    {
        MessageBox.Show("Starting of 5000 ms...");
        Sleep(5000);
        MessageBox.Show("End of 5000 ms...");
    }
}

```

(B)When we use windows API in .NET is it managed or unmanaged code ?

Windows API in .NET is unmanaged code.

Note:- Even though VB6 and V C++ has gone off still many people do ask these old questions again and again. Still there are decent old application which are working with COM very much fine. So interviewer still asks you these questions so that those application's can be ported to .NET. So let's play some old music... By the way my favourite music is Kishore, what's yours???

(I)What is COM ?

Microsoft's COM is a technology for component software development. It is a binary standard which is language independent. DCOM is a distributed extension of COM.

(A) What is Reference counting in COM ?

Reference counting is a memory management technique used to count how many times an object has a pointer referring to it. The first time it is created, the reference count is set to one. When the last reference to the object is nulled, the reference count is set to zero and the object is deleted. Care must be exercised to prevent a context switch from changing the reference count at the time of deletion. In the methods that follow, the syntax is shortened to keep the scope of the discussion brief and manageable.

(A) Can you describe IUNKNOWN interface in short ?

Every COM object supports at least one interface, the IUnknown interface. All interfaces are classes derived from the base class IUnknown. Each interface supports methods access data and perform operations transparently to the programmer. For example, IUnknown supports three methods, AddRef, Release(), and QueryInterface(). Suppose that pinterf is a pointer to an IUnknown. pinterf->AddRef() increments the reference count. pinterf->Release() decrements the reference count, deleting the object when the reference count reaches zero. pinterf->QueryInterface(IDesired,

pDesired) checks to see if the current interface (IUnknown) supports another interface, IDesired, creates an instance (via a call to CoCreateInstance()) of the object if the reference count is zero (the object does not yet exist), and then calls pDesired->AddRef() to increment the reference count (where pDesired is a pointer to IDesired) and returns the pointer to the caller.

(I)Can you explain what is DCOM ?

DCOM differs from COM in that it allows for creating objects distributed across a network, a protocol for invoking that object's methods, and secures access to the object. DCOM provides a wrapper around COM, hence it is a backwards compatible extension. DCOM uses Remote Procedural Calls (RPC) using Open Software Foundation's Distributed Computing Environment.

These RPC are implemented over TCP/IP and named pipes. The protocol which is actually being used is registered just prior to use, as opposed to being registered at initialization time. The reason for this is that if a protocol is not being used, it will not be loaded.

In order to inform an object that the client is still alive, periodic pinging is used. Hence, when the client has died and no ping has been received (to refresh it) before the expiration time, the server object will perform some clean up tasks (including decrementing its reference count).

Since RPC across a network are typically slow (compared to processes residing on the same machine), DCOM sends multiple requests in the same call. For example, in COM, the program performs a QueryInterface, one interface at a time. In DCOM, multiple QueryInterfaces are all clustered into one call.

This clustering optimization trick is also used when creating an instance of the object and serializing it with data. Since these two operations usually occur together, DCOM allows one method which will perform both operations in one call without waiting for an acknowledgment from the first task before performing the second one.

Similarly, when a client pings its server object, he can do it in one call. Moreover, if there are multiple clients sending pings to multiple servers, an optimization is made where the multiple pings going to the same object are consolidated into just one ping. This is to cut down on the use of precious bandwidth used only for pinging.

The client has the control to set the computer which will be responsible for the lifetime of the object. That is to say, these objects are not created just somewhere where the system resources and access privileges allow for it.

Call security is implemented in all four ways: authentication (to prevent false clients from impersonating the true client), authorization (to insure that a client only does what it is authorized to do), data integrity (to insure that data was not tampered with during transit) and data privacy (to insure that only designated sources can read it). The security issues are handled as they are on

operating systems. The client gives the server various access privileges to access memory or disk space

(B)How do we create DCOM object in VB6?

Using the CreateObject method you can create a DCOM object. You have to put the server name in the registry.

(A)How to implement DTC in .NET ?

DTC is implemented using COM+.

Following are the steps to implement COM + in .NET :-

- √ “EnterpriseService” namespace has all the classes by which we can implement DTC in .NET. You have to add reference “EnterpriseService” namespace.

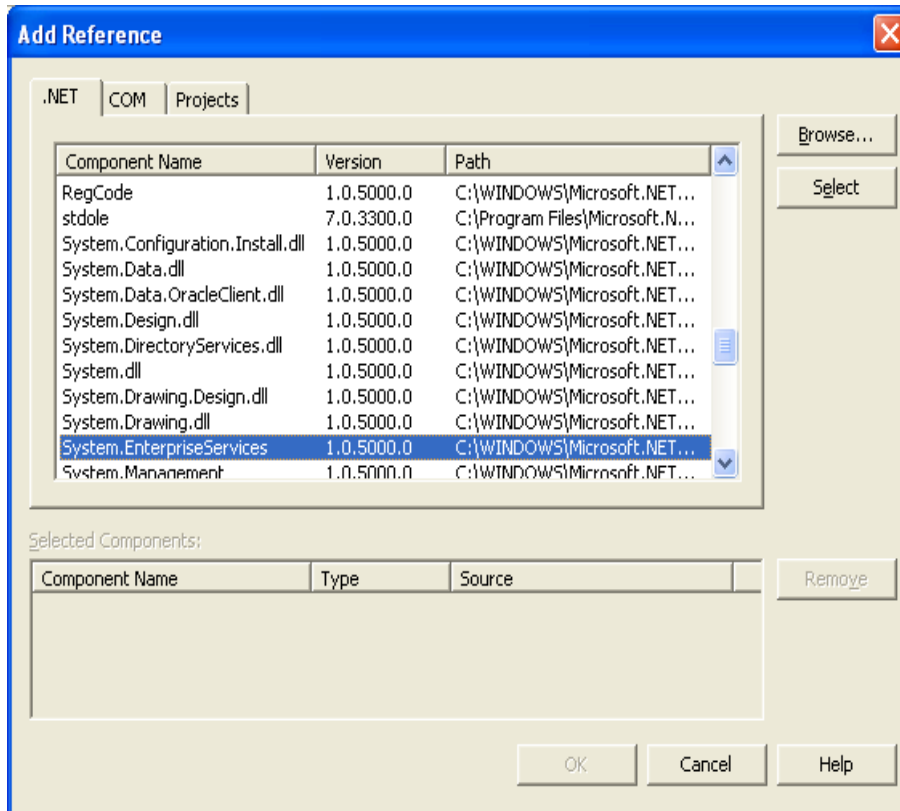

Figure :- 2.3 Add reference to EnterpriseServices.

- √ You class must derive from “Serviced Component” object.
- √ Then you have to define your class with the transaction attribute

(For all transaction attribute look the down question)

[Transaction(TransactionOption.RequiresNew)]

- √ After the class level transaction type is defined. Its time to define at the method level the AutoComplete attribute. Autocomplete attribute says that if no exception is thrown then mark its part of the transaction as being okay. This helps cut down on the amount of code required. If the implementation sets AutoComplete to false, or

omits it all together, then we would need to manage the transaction manually. To manually control the transaction you will need to use the ContextUtil class and its static members. Following is small snippet of ContextUtil: -

```
public void SampleFunction()  
{  
    try  
    {  
        // Do something to a database  
        // ...  
        // Everything okay so far Commit the transaction  
  
        ContextUtil.SetComplete();  
    }  
    catch(Exception)  
    {  
        // Something went wrong Abort and Rollback the Transaction.  
        ContextUtil.SetAbort();  
    }  
}
```

- √ Component derived from “ServicedComponent” should be strong named as they run under COM+.
- √ Once the classes are compiled using the string name. Register the Component in COM+ services using

```
regsvcs c:\DllPath\TransactionComponent.dll
```

- √ You can see that the component is registered using the COM+ explorer.

(A)How many types of Transactions are there in COM + .NET ?

There are 5 transactions types that can be used with COM+. Whenever an object is registered with COM+ it has to abide either to these 5 transaction types.

Disabled: - There is no transaction. COM+ does not provide transaction support for this component.

Not Supported: - Component does not support transactions. Hence even if the calling component in the hierarchy is transaction enabled this component will not participate in the transaction.

Supported: - Components with transaction type support will be a part of the transaction. This will be only if the calling component has an active transaction. If the calling component is not transaction enabled this component will not start a new transaction.

Required: - Components with this attribute require a transaction i.e. either the calling should have a transaction in place else this component will start a new transaction.

Required New: - Components enabled with this transaction type always require a new transaction. Components with required new transaction type instantiate a new transaction for themselves every time.

(A)How do you do object pooling in .NET ?

COM+ reduces overhead by creating object from scratch. So in COM+ when object is activated its activated from pool and when its deactivated it's pushed back to the pool. Object pooling is configures by using the "ObjectPoolingAttribute" to the class.

Note:- When a class is marked with objectpooling attribute it can not be inherited.

```
ObjectPooling(MinPoolSize := 2, MaxPoolSize := 5, CreationTimeout := 20000)> _
```

```
Public Class testingclass
```

```
Inherits ServicedComponent
```

```
Public Sub DoWork()
```

```
' Method contents go here.
```

```
End Sub
```

```
End Class
```

Above is a sample code which has the "ObjectPooling" attribute defined. Below is a sample code which uses the class.

Public Class App

Overloads Public Shared Sub Main(args() As String)

Dim xyz As New TestObjectPooling()

xyz.doWork()

ServicedComponent.DisposeObject (xyz)

End Sub

End Class

Above is a sample code which uses the object pooled object. Note the DisposeObject() This ensures its safe return to the object pool.

(A)What are types of compatibility in VB6?

There are three possible project compatibility settings:

- √ No Compatibility
- √ Project Compatibility
- √ Binary Compatibility

No Compatibility

With this setting, new class ID's, new interface ID's and a new type library ID will be generated by VB each time the ActiveX component project is compiled. This will cause any compiled client components to fail (with error 429!) and report a missing reference to the 'VB ActiveX Test Component' when a client project is loaded in the VB IDE.

Note :- Use this setting to compile the initial release of a component to other developers.

Project Compatibility

With this setting, VB will generate new interface ID's for classes whose interfaces have changed, but will not change the class ID's or the type library ID. This will still cause any compiled client components to fail (with error 429!) but will not report a missing reference to the 'VB ActiveX Test Component' when a client project is loaded in the VB IDE. Recompilation of client components will restore them to working order again.

Note:- Use this setting during the initial development and testing of a component within the IDE and before the component is released to other developers.

Binary Compatibility

VB makes it possible to extend an existing class or interface by adding new methods and properties etc. and yet still retain binary compatibility. It can do this, because it silently creates a new interface ID for the extended interface and adds registration code to register the original interface ID but with a new Forward key containing the value of this new interface ID. COM will then substitute calls having the old ID with the new ID and hence applications built against the old interface will continue to work (assuming the inner workings of the component remain backward compatible!).

With this setting, VB will not change any of the existing class, interface or type library ID's, however in order that it can do so, VB requires the project to specify an existing compiled version that it can compare against to ensure that existing interfaces have not been broken

(A)What is equivalent for regsvr32 exe in .NET ?

Regasm

3. Threading

(B)What is Multi-tasking ?

It's a feature of modern operating systems with which we can run multiple programs at same time example Word, Excel etc.

(B)What is Multi-threading ?

Multi-threading forms subset of Multi-tasking. Instead of having to switch between programs this feature switches between different parts of the same program. Example you are writing in word and at the same time word is doing a spell check in background.

(B)What is a Thread ?

A thread is the basic unit to which the operating system allocates processor time.

(B)Did VB6 support multi-threading ?

While VB6 supports multiple single-threaded apartments, it does not support a free-threading model, which allows multiple threads to run against the same set of data.

(B)Can we have multiple threads in one App domain ?

One or more threads run in an AppDomain. An AppDomain is a runtime representation of a logical process within a physical process. Each AppDomain is started with a single thread, but can create additional threads from any of its threads.

Note :- All threading classes are defined in System.Threading namespace.

(B)Which namespace has threading ?

System.Threading has all the classes related to implement threading. Any .NET application who wants to implement threading has to import this namespace.

Note :- .NET program always has at least two threads running one is the main program and second is the garbage collector.

(I)Can you explain in brief how can we implement threading ?

```

Private Sub Form1_Load(ByVal sender As System.Object, ByVal e As
System.EventArgs) Handles MyBase.Load
    Dim pthread1 As New Thread(AddressOf Thread1)
    Dim pthread2 As New Thread(AddressOf Thread2)
    pthread1.Start()
    pthread2.Start()
End Sub
Public Sub Thread1()
    Dim pintcount As Integer
    Dim pstr As String
    pstr = "This is first thread"
    Do Until pintcount > 5
        lstThreadDisplay.Items.Add(pstr)
        pintcount = pintcount + 1

        Loop
End Sub
Public Sub Thread2()
    Dim pintcount As Integer
    Dim pstr As String
    pstr = "This is second thread"
    Do Until pintcount > 5
        lstThreadDisplay.Items.Add(pstr)
        pintcount = pintcount + 1

        Loop
End Sub

```

Above is a sample code which shows simple sample code for threading. Above sample code can be found in "Threading" folder in CD provided. Above sample has two methods "Thread1()" and "Thread2()" which are started in multi-threaded mode in Form load event of the sample.

Note :- If you run the sample you will see that sometimes the first thread runs first and then the second thread. This happens because of thread priorities . The first thread is run with highest priority.

(A)How can we change priority and what the levels of priority are provided by .NET ?

Thread Priority can be changed by using `Threadname.Priority = ThreadPriority.Highest`. In the sample provided look out for code where the second thread is ran with a high priority.

Following are different levels of Priority provided by .NET :-

- √ `ThreadPriority.Highest`
- √ `ThreadPriority.AboveNormal`
- √ `ThreadPriority.Normal`
- √ `ThreadPriority.BelowNormal`
- √ `ThreadPriority.Lowest`

(A)What does AddressOf operator do in background ?

The AddressOf operator creates a delegate object to the BackgroundProcess method. A delegate within VB.NET is a type-safe, object-oriented function pointer. After the thread has been instantiated, you begin the execution of the code by calling the Start() method of the thread

(A)How can you reference current thread of the method ?

"Thread.CurrentThread" refers to the current thread running in the method."CurrentThread" is a public static property.

(I) What's Thread.Sleep() in threading ?

Thread's execution can be paused by calling the Thread.Sleep method. This method takes an integer value that determines how long the thread should sleep. Example `Thread.CurrentThread.Sleep(2000)`.

(A)How can we make a thread sleep for infinite period ?

You can also place a thread into the sleep state for an indeterminate amount of time by calling `Thread.Sleep (System.Threading.Timeout.Infinite)`. To interrupt this sleep you can call the `Thread.Interrupt` method.

(A) What is Suspend and Resume in Threading ?

It is Similar to Sleep and Interrupt. Suspend allows you to block a thread until another thread calls Thread.Resume. The difference between Sleep and Suspend is that the latter does not immediately place a thread in the wait state. The thread does not suspend until the .NET runtime determines that it is in a safe place to suspend it. Sleep will immediately place a thread in a wait state.

Note :- In threading interviews most people get confused with Sleep and Suspend. They look very similar.

(A)What the way to stop a long running thread ?

Thread.Abort() stops the thread execution at that moment itself.

(A) How do I debug thread ?

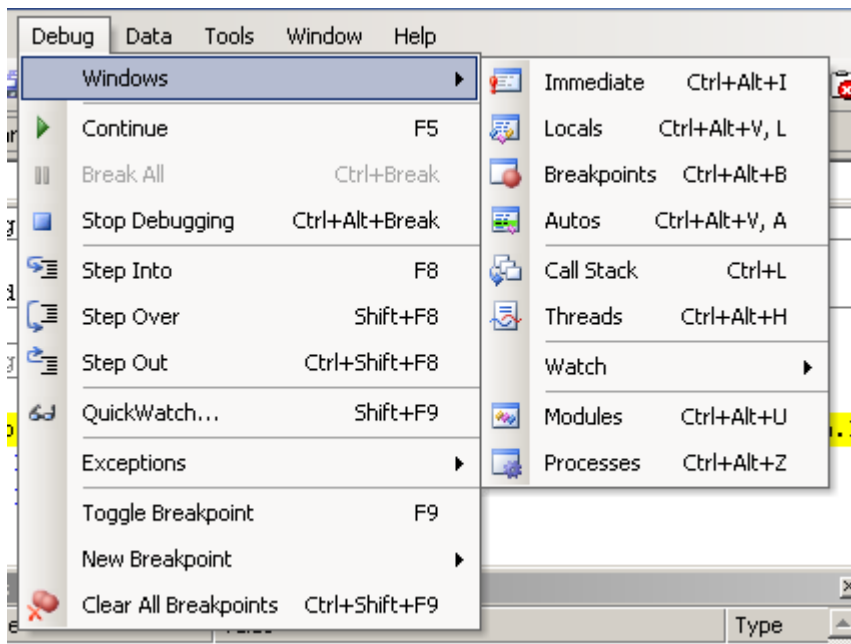

Figure :- 3.1 Debug thread window

This window is only seen when the program is running in debug mode. In windows one of the window is “Threads”.

(A)What is Thread.Join() in threading ?

There are two versions of Thread.Join :-

- √ Thread.join().
- √ Thread.join(Integer) this returns a Boolean value.

The Thread.Join method is useful for determining if a thread has completed before starting another task. The Join method waits a specified amount of time for a thread to end. If the thread ends before the time-out, Join returns true; otherwise it returns False. Once you call Join, the calling procedure stops and waits for the thread to signal that it is done.

Example you have "Thread1" and "Thread2" and while executing "Thread1" you call "Thread2.Join()".So "Thread1" will wait until "Thread2" has completed its execution and the again invoke "Thread1".

Thread.Join(Integer) ensures that threads do not wait for a long time. If it exceeds a specific time which is provided in integer the waiting thread will start.

(A)What are Daemon threads and how can a thread be created as**Daemon?**

Daemon thread's run in background and stop automatically when nothing is running program. Example of a Daemon thread is "Garbage collector". Garbage collector runs until some .NET code is running or else its idle.

You can make a thread Daemon by

Thread.Isbackground=true

(A) When working with shared data in threading how do you implement synchronization ?

There are certain situations that you need to be careful with when using threads. If two threads (e.g the main and any worker threads) try to access the same variable at the same time, you'll have a problem. This can be very difficult to debug because they may not always do it at exactly the same time. To avoid the problem, you can lock a variable

before accessing it. However, if the two threads lock the same variable at the same time, you'll have a deadlock problem.

SyncLock x

'Do something with x

End SyncLock

(I) Can we use events with threading ?

Yes, you can use events with thread; this is one of the techniques to synchronize one thread with other.

(A) How can we know a state of a thread?

"ThreadState" property can be used to get detail of a thread. Thread can have one or a combination of status.System.Threading.ThreadState enumeration has all the values to detect a state of thread. Some sample states are Isrunning, IsAlive, suspended etc.

(A) What is use of Interlocked class ?

Interlocked class provides methods by which you can achieve following functionalities :-

- √ Increment Values.
- √ Decrement values.
- √ Exchange values between variables.
- √ Compare values from any thread.

in a synchronization mode.

Example :- System.Threading.Interlocked.Increment(IntA)

(A) What is a monitor object?

Monitor objects are used to ensure that a block of code runs without being interrupted by code running on other threads. In other words, code in other threads cannot run until code in the synchronized code block has finished.

SyncLock and End SyncLock statements are provided in order to simplify access to monitor object.

(A) What are wait handles ?

Twist :- What is a mutex object ?

Wait handles sends signals of a thread status from one thread to other thread. There are three kind of wait modes :-

- √ WaitOne.
- √ WaitAny.
- √ WaitAll.

When a thread wants to release a Wait handle it can call Set method. You can use Mutex (mutually exclusive) objects to avail for the following modes. Mutex objects are synchronization objects that can only be owned by a single thread at a time. Threads request ownership of the mutex object when they require exclusive access to a resource. Because only one thread can own a mutex object at any time, other threads must wait for ownership of a mutex object before using the resource.

The WaitOne method causes a calling thread to wait for ownership of a mutex object. If a thread terminates normally while owning a mutex object, the state of the mutex object is set to be signaled and the next waiting thread gets ownership

(A) What is ManualResetEvent and AutoResetEvent ?

Threads that call one of the wait methods of a synchronization event must wait until another thread signals the event by calling the Set method. There are two synchronization event classes. Threads set the status of ManualResetEvent instances to signaled using the Set method. Threads set the status of ManualResetEvent instances to no signaled using the Reset method or when control returns to a waiting WaitOne call. Instances of the AutoResetEvent class can also be set to signaled using Set, but they automatically return to nonsignaled as soon as a waiting thread is notified that the event became signaled.

(A) What is ReaderWriter Locks ?

You may want to lock a resource only when data is being written and permit multiple clients to simultaneously read data when data is not being updated. The ReaderWriterLock class enforces exclusive access to a resource while a thread is modifying the resource, but it allows nonexclusive access when reading the resource. ReaderWriter locks are a useful

alternative to exclusive locks that cause other threads to wait, even when those threads do not need to update data.

(I) How can you avoid deadlock in threading?

A good and careful planning can avoid deadlocks. There are so many ways Microsoft has provided by which you can reduce deadlocks example Monitor, Interlocked classes, Wait handles, Event raising from one thread to other thread, ThreadState property which you can poll and act accordingly etc.

(B) What is the difference between thread and process?

A thread is a path of execution that run on CPU, a process is a collection of threads that share the same virtual memory. A process has at least one thread of execution, and a thread always run in a process context.

Note:- Its difficult to cover threading interview question in this small chapter. These questions can take only to a basic level. If you are attending interviews where people are looking for threading specialist, try to get deeper in to synchronization issues as that's the important point they will stress.

4. Remoting and Webservices

(B) What is an application domain?

Previously “PROCESS” were used as security boundaries. One process has its own virtual memory and does not overlap the other process virtual memory; due to this one process can not crash the other process. So any problem or error in one process does not affect the other process. In .NET they went one step ahead introducing application domains. In application domains multiple applications can run in same process without influencing each other. If one of the application domains throws an error it does not affect the other application domains. To invoke a method in an object running in a different application domain .NET remoting is used.

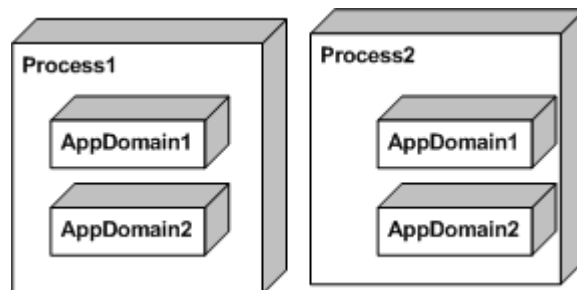

Figure :- 4.1 One process can have multiple Application domains

(B) What is .NET Remoting ?

.NET remoting is a replacement of DCOM. Using .NET remoting you can make remote object calls which lie in different Application Domains. As the remote objects run in different processes, a client calling the remote object cannot call it directly. So the client uses a proxy which looks like a real object.

When a client wants to make a method call on the remote object, it uses a proxy for it. These method calls are called as “Messages”. Messages are serialized using a “formatter” class and sent to the client “channel”. The client channel communicates with the server channel. The server channel uses a formatter to deserialize the message and sends it to the remote object.

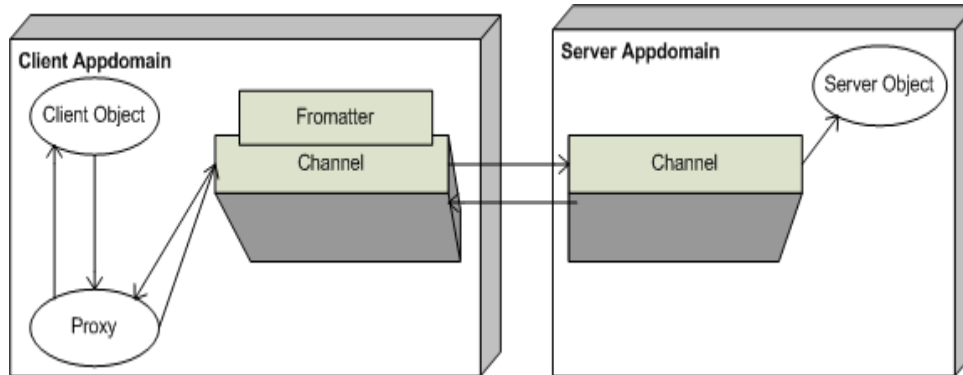

Figure :- 4.2 Channels, Formatters and Proxy in action.

(B) Which class does the remote object has to inherit ?

All remote objects should inherit from System.MarshalbyRefObject.

(I) What are two different types of remote object creation mode in .NET ?

There are two different ways in which object can be created using Remoting :-

- √ SAO (Server Activated Objects) also called as Well-Known call mode.
- √ CAO (Client Activated Objects)

SAO has two modes “Single Call” and “Singleton”. With Single Call object the object is created with every method call thus making the object stateless. With Singleton the object is created only once and the object is shared with all clients.

CAO are stateful as compared to SAO. In CAO the creation request is sent from client side. Client holds a proxy to the server object created on server.

(A) Describe in detail Basic of SAO architecture of Remoting?

For these types of questions interviewer expects small and sweet answers. He is basically looking at what you know about the specific subject. For these type of question this book will provide detail code which is not necessary to be said during interview. Only the basic steps and overall brief are enough to convince that you have knowledge about the subject. Even though this question has detail code and answer say only what is needed in interview.

Remoting has at least three sections :-

- √ Common Interface which will be shared between them.
- √ Server.
- √ Client.

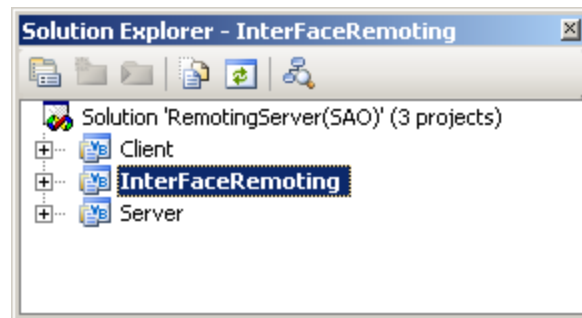

Figure :- 4.3 Solution Explorer of Remoting Project

In CD “RemotingSample(SAO)” project is provided which gives a insight of remoting Above is the figure which shows the three important project sections needed to implement remoting

First important section is the common interface between Server and Client.”InterFaceRemoting” project has the interface code. For sample project interface is very simple with only two methods :- SetValue and GetValue.

```
Public Interface InterFaceRemoting
    Sub SetValue(ByVal value As String)
    Function GetValue() As String
End Interface
```

Second important section is the server. In this sample server is using HTTP channel and the server object is singleton.

```
Imports System
Imports System.Runtime.Remoting
Imports System.Runtime.Remoting.Channels.Http
Imports System.Runtime.Remoting.Channels
Imports InterFaceRemoting

Public Class RemotingServer
    Inherits MarshalByRefObject
```

```

    Implements InterFaceRemoting.InterFaceRemoting
    Private strData As String
    Public Function GetValue() As String Implements
InterFaceRemoting.InterFaceRemoting.GetValue
        Return strData
    End Function
    Sub New()
        strData = "testing.."
    End Sub
    Public Sub SetValue(ByVal value As String) Implements
InterFaceRemoting.InterFaceRemoting.SetValue
        strData = value
    End Sub
End Class
Module ModuleRemotingStartUp
    Sub Main()
        Dim objHttpChannel As HttpChannel
        Console.WriteLine("Server Started...")
        objHttpChannel = New HttpChannel(1234)
        ChannelServices.RegisterChannel(objHttpChannel)
        RemotingConfiguration.RegisterWellKnownServiceType(GetType(RemotingServer),
"RemoteObject", WellKnownObjectMode.Singleton)
        Console.WriteLine("Server registered and listening waiting
for clients...")
        Console.ReadLine()

    End Sub
End Module

```

Following is detail explanation :-

√ Channel object is created and registered.

Following is the code.

```

Dim objHttpChannel As HttpChannel
Console.WriteLine("Server Started...")
objHttpChannel = New HttpChannel(1234)
ChannelServices.RegisterChannel(objHttpChannel)

```

√ Server then hosts the object so that client can connect to it. This is the time when we specify what mode the server object will be created i.e. Singleton or SingleCall. This is done by the following below given code. Note in sample we

are hosting the server object in singleton mode that means that the same object will be shared between all clients. Also note the server object is implementing “InterFaceRemoting” and inheriting from “MarshalByRefObject”.

*RemotingConfiguration.RegisterWellKnownServiceType(GetType(RemotingServer),
“RemoteObject”, WellKnownObjectMode.Singleton)*

Now comes the final section that is third section the client which will connect to this hosted remoting object.

Following is a detail explanation of client code :-

- √ First we create the channel i.e. HTTP. Note whatever channel the server is using same will be used by the client.

ChannelServices.RegisterChannel(objHttpChannel)

- √ As said before the common interface i.e. “InterFaceRemoting” will be used to communicate with client.

- √ After that we can get the server object reference using following code

*objRemoting = CType(Activator.GetObject(GetType(InterFaceRemoting),
“http://localhost:1234/RemoteObject”), InterFaceRemoting)*

- √ Then the client can make method call as if the object is local. But actually the object is a proxy.

Console.WriteLine(“Value on server :- “ & objRemoting.GetValue.ToString())

```
Imports System
Imports System.Runtime.Remoting
Imports System.Runtime.Remoting.Channels.Http
Imports System.Runtime.Remoting.Channels
Imports InterFaceRemoting

Module ModuleStartClient
    Sub Main()
        Dim objHttpChannel As New HttpChannel
        Dim objRemoting As InterFaceRemoting
        ChannelServices.RegisterChannel(objHttpChannel)
        objRemoting =
CType(Activator.GetObject(GetType(InterFaceRemoting),
“http://localhost:1234/RemoteObject”),
```

```

InterFaceRemoting.InterFaceRemoting)
    Console.WriteLine("Referenced the main object.... Now
displaying Data")
    Console.WriteLine("Value on server :- " &
objRemoting.GetValue.ToString())
    Console.WriteLine("Press enter to Terminate")
    Console.ReadLine()
End Sub

```

End Module

You can run the program and see the output. For running the program run the server program which is in server directory. Run "Server.exe" from BIN directory. If the EXE runs properly following will be the screen as shown below.

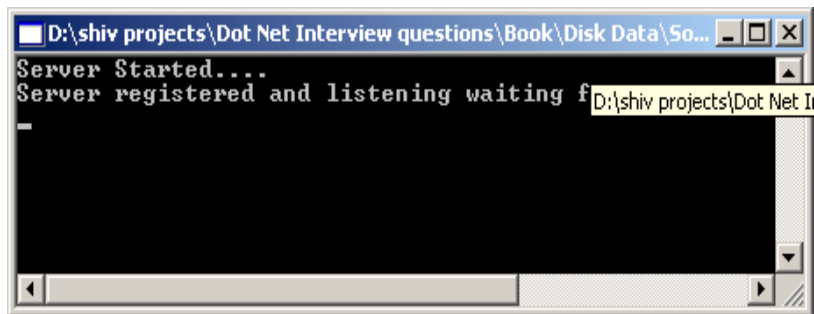

Figure :- 4.4 Running Server Program of Remoting

Now run "Client.exe" from client folder in BIN directory. Following will be the output seen. This means that the client connected to the server program and displayed the data in the server object. In the server object we have initialized value "testing.....". In constructor of class "RemotingServer" same value is displayed at the client side as shown in figure below.

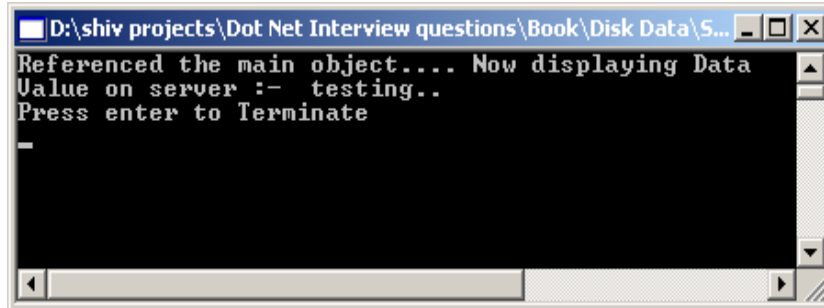

Figure :- 4.5 Client Program output of Remoting

(A) What are the situations you will use singleton architecture in remoting ?

If all remoting clients have to share the same data singleton architecture will be used.

(A) What is fundamental of published or precreated objects in Remoting ?

In scenarios of singleton or single call the objects are created dynamically. But in situations where you want to precreate object and publish it you will use published object scenarios.

```
Dim obj as new objRemote  
obj.Initvalue = 100  
RemotingServices.Marshal(obj, "RemoteObject")
```

As shown in above sample following changes will be needed on server side. `RemotingConfiguration.RegisterWellKnownServiceType` is replaced by `RemotingServices.Marshal(obj, "RemoteObject")` where "obj" is the precreated object on the server whose value is initialized to 100.

(A) What are the ways in which client can create object on server in CAO model ?

There are two ways by which you can create Client objects on remoting server :-

√ Activator.CreateInstance().

√ By Keyword “New”.

(A) Are CAO stateful in nature ?

Yes. In CAO remoting model client creates a instance on server and instance variable set by client on server can be retrieved again with correct value.

(A) In CAO model for client objects to be created by “NEW” keyword what should we do?

Remoting Clients and Remoting Server can communicate because they share a common contract by implementing Shared Interface or Base Class (As seen in previous examples). But according to OOP’s concept we can not create a object of interface or Base Classes (Abstract Class). Shipping the server object to client is not a good design practice. In CAO model we can use SOAPSUDS utility to generate Metadata DLL from server which can be shipped to client, clients can then use this DLL for creating object on server. Run the SOAPSUDS utility from visual studio command prompt for syntax see below :-

soapsuds -ia:RemotingServer -nowp -oa:ClientMetaData.dll

Where RemotingServer is your server class name.

ClientMetaData.dll is the DLL name by which you will want to create the metadll.

Server code will change as follows :-

```
ChannelServices.RegisterChannel(objHttpChannel)
RemotingConfiguration.ApplicationName = "RemoteObject"
RemotingConfiguration.RegisterActivatedServiceType(GetType(InterfaceRemoting.InterfaceRemoting))
```

Note :- We have to provide applicationname and register the object as ActivatedServiceType.

On client side we have to reference the generated ClientMetaData.dll from SOAPSUDS utility. Below are changes which are needed to be incorporated at the Remoting Client :-

RemotingConfiguration.RegisterActivatedClientType(typeof(RemoteObject), "http://localhost:1234/MyServer")

Dim objRemoteObject as new RemoteObject().

RemoteObject is class which is obtained from ClientMetaData.dll which we created using SOAPSUDS utility. Now you can reference the object as normal object.

(I) Is it a good design practice to distribute the implementation to Remoting Client ?

It's never advisable to distribute complete implementation at client, due to following reasons:-

- √ Any one can use ILDASM and decrypt your logic.
- √ It's a bad architecture move to have full implementation as client side as any changes in implementation on server side you have to redistribute it again.

So the best way is to have a interface or SOAPSUDS generated meta-data DLL at client side rather than having full implementation.

(A) What are LeaseTime, SponsorshipTime, RenewonCallTime and LeaseManagerPollTime?

This is a very important question from practical implementation point of view. Companies who have specific requirement for Remoting projects will expect this question to be answered.

In normal .NET environment objects lifetime is managed by garbage collector. But in remoting environment remote clients can access objects which are out of control of garbage collector. Garbage collector boundary is limited to a single PC on which framework is running; any remote client across physical PC is out of control of GC (Garbage Collector).

This constraint of garbage collector leads to a new way of handling lifetime for remoting objects, by using concept called as "LeaseTime". Every server side object is assigned by default a "LeaseTime" of five minutes. This leasetime is decreased at certain intervals. Again for every method call a default of two minutes is assigned. When i say method call means every call made from client. This is called as "RenewalOnCallTime".

Let's put the whole thing in equation to make the concept more clear.

Total Remoting object life time = LeaseTime + (Number of method calls) X (RenewalTime).

If we take NumberOfMethodCalls as one.

Then default Remote Object Life Time = 5 + (1) X 2 = 10 minutes (Everything is in minutes)

When total object lifetime is reduced to zero, it queries the sponsor that should the object be destroyed. Sponsor is an object which decides should object Lifetime be renewed. So it queries any registered sponsors with the object, if does not find any then the object is marked for garbage collection. After this garbage collection has whole control on the object lifetime. If we do not foresee how long a object will be needed specify the "SponsorShipTimeOut" value. SponsorShipTimeOut is time unit a call to a sponsor is timed out.

"LeaseManagerPollTime" defines the time the sponsor has to return a lease time extension.

(A) Which config file has all the supported channels/protocol ?

Machine.config file has all the supported channels and formatter supported by .NET remoting. Machine.config file can be found at

"C:\WINDOWS\Microsoft.NET\Framework\vXXXXX\CONFIG" path. Find <system.runtime.remoting> element in the Machine.config file which has the channels and the formatters. Below is a figure shown which can give a clear idea of how the file looks like.

Note :- Interviewer will not ask you to name all channels and formatters in machine.config but will definitely like to know in which file are all the formatter and channels specified, one sweet answer "Machine.config" can fetch you handsome job.

```
<runtime />
<system.runtime.remoting>
  <application>
    <channels>
      <channel ref="http client" displayName="http client (delay
loaded)" delayLoadAsClientChannel="true" />
      <channel ref="tcp client" displayName="tcp client (delay loaded)"
delayLoadAsClientChannel="true" />
      <channel ref="ipc client" displayName="ipc client (delay loaded)"
delayLoadAsClientChannel="true" />
    </channels>
  </application>
  <channels>
    <channel id="http"
type="System.Runtime.Remoting.Channels.Http.HttpChannel,
System.Runtime.Remoting, Version=2.0.3600.0, Culture=neutral,
PublicKeyToken=b77a5c561934e089" />
    <channel id="http client"
type="System.Runtime.Remoting.Channels.Http.HttpClientChannel,
System.Runtime.Remoting, Version=2.0.3600.0, Culture=neutral,
PublicKeyToken=b77a5c561934e089" />
    <channel id="http server"
type="System.Runtime.Remoting.Channels.Http.HttpServerChannel,
System.Runtime.Remoting, Version=2.0.3600.0, Culture=neutral,
PublicKeyToken=b77a5c561934e089" />
    <channel id="tcp"
type="System.Runtime.Remoting.Channels.Tcp.TcpChannel,
```

Figure :- 4.6 Channels and Formatter in machine.config file

(A) How can you specify remoting parameters using Config files ?

Both remoting server and remoting client parameters can be provided through config files. Below is a sample of server config file which provides all remoting parameter values which we were providing through code.

```
<configuration>
<system.runtime.remoting>
<application name="Server">
<service>
<wellknown
```

```

mode="SingleCall"
type="Server.ClsServer, Server"
objectUri="RemoteObject" />
</service>
<channels>
<channel ref="tcp server" port="9000" />
</channels>
</application>
</system.runtime.remoting>
</configuration>

```

Later this config file can be loaded using the following code.

```

RemotingConfiguration.Configure(AppDomain.CurrentDomain.SetupInformation.ApplicationBase
& "Server.config")

```

Same way we also have client.config file for loading the client remoting parameters.

```

<configuration>
<system.runtime.remoting>
<application name="Client">
<client url="tcp://localhost:9000/RemoteObject">
<wellknown
type="CommonInterface.Icommon, Icommon"
url = "tcp://localhost:9000/Server/RemoteObject"/>
</client>
<channels>
<channel ref="tcp client" />
</channels>
</application>
</system.runtime.remoting>
</configuration>

```

client remoting can then load the configuration file by using :-

```

Dim IobjCommon As CommonInterFace.Icommon
Dim StrData As String
Dim objServiceEntries As WellKnownClientTypeEntry()

RemotingConfiguration.Configure(AppDomain.CurrentDomain.SetupInformation.ApplicationBase
& "Client.config")
objServiceEntries =
RemotingConfiguration.GetRegisteredWellKnownClientTypes()
IobjCommon = Activator.GetObject(GetType(Icommon),
objServiceEntries(0).ObjectUrl.ToString())
StrData = IobjCommon.GetValue()

```

```
Console.WriteLine(" Serve side Data is " & StrData)
Console.ReadLine()
```

Note :- Complete source is provided in CD in folder "RemotingObjectLifeTime".If you run Server and Client following output can be seen. All source is compiled using VS2005 BETA1

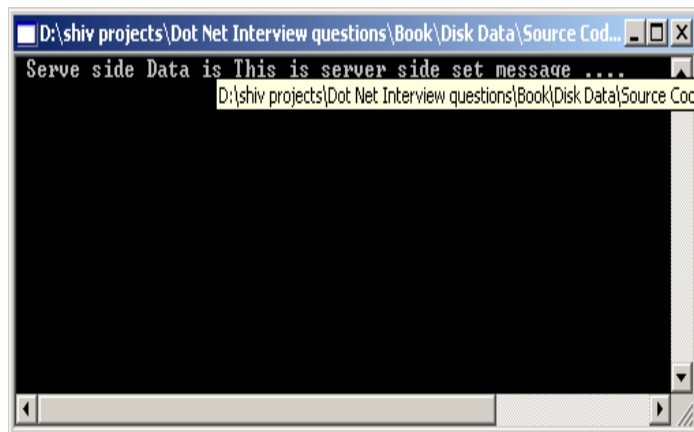
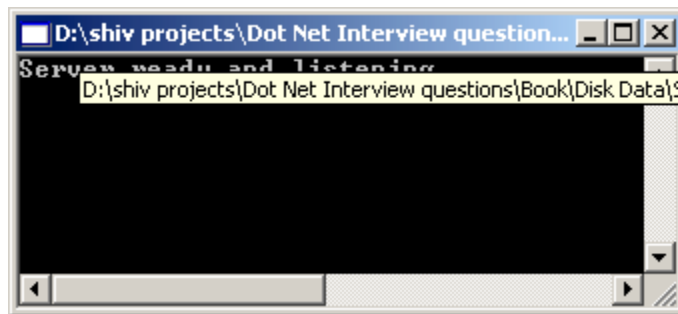

Figure : - 4.7 Output of Server and Client for RemotingObjectLifeTime project

(A) Can Non-Default constructors be used with Single Call SAO?

Twist :- What are the limitation of constructors for Single call SAO ?

Non-Default constructors can not be used with single call objects as object is created with every method call, there is no way to define Non-default constructors in method calls.

It's possible to use Non-Default constructor with Client activated objects as both methods :-

“NEW” keyword and “Activator.CreateInstance” provide a way to specify Non-Default constructors.

(I) How can we call methods in remoting Asynchronously ?

All previous examples are a synchronous method calls that means client has to wait until the method completes the process. By using Delegates we can make Asynchronous method calls.

(A) What is Asynchronous One-Way Calls ?

One-way calls are a different from asynchronous calls from execution angle that the .NET Framework does not guarantee their execution. In addition, the methods used in this kind of call cannot have return values or out parameters. One-way calls are defined by using [OneWay()] attribute in class.

(B) What is marshalling and what are different kinds of marshalling ?

Marshaling is used when an object is converted so that it can be sent across the network or across application domains. Unmarshaling creates an object from the marshaled data. There are two ways to do marshalling :-

- √ Marshal-by-value (MBV) :- In this the object is serialized into the channel, and a copy of the object is created on the other side of the network. The object to marshal is stored into a stream, and the stream is used to build a copy of the object on the other side with the unmarshalling sequence.
- √ Marshaling-by-reference (MBR):- Here it creates a proxy on the client that is used to communicate with the remote object. The marshaling sequence of a remote object creates an ObjRef instance that itself can be serialized across the network.

Objects that are derived from “MarshalByRefObject” are always marshaled by reference. All our previous samples have classes inherited from “MarshalByRefObject”

To marshal a remote object the static method `RemotingServices.Marshal()` is used. `RemotingServices.Marshal()` has following overloaded versions:-

```
public static ObjRef Marshal(MarshalByRefObject obj)
public static ObjRef Marshal(MarshalByRefObject obj, string objUri)
public static ObjRef Marshal(MarshalByRefObject obj, string objUri, Type
requestedType)
```

The first argument `obj` specifies the object to marshal. The `objUri` is the path that is stored within the marshaled object reference; it can be used to access the remote object. The `requestedType` can be used to pass a different type of the object to the object reference. This is useful if the client using the remote object shouldn't use the object class but an interface that the remote object class implements instead. In this scenario the interface is the `requestedType` that should be used for marshaling.

(A) What is ObjRef object in remoting ?

All `Marshal()` methods return `ObjRef` object. The `ObjRef` is serializable because it implements the interface `ISerializable`, and can be marshaled by value. The `ObjRef` knows about :-

- √ location of the remote object
- √ host name
- √ port number
- √ object name.

(B) What is a Web Service ?

Web Services are business logic components which provide functionality via the Internet using standard protocols such as HTTP.

Web Services uses Simple Object Access Protocol (SOAP) in order to expose the business functionality. SOAP defines a standardized format in XML which can be exchanged between two entities over standard protocols such as HTTP. SOAP is platform independent so the consumer of a Web Service is therefore completely shielded from any implementation details about the platform exposing the Web Service. For the consumer it is simply a black box of send and receive XML over HTTP. So any web service hosted on windows can also be consumed by UNIX and LINUX platform.

(B) What is UDDI ?

Full form of UDDI is Universal Description, Discovery and Integration. It is a directory that can be used to publish and discover public Web Services. If you want to see more details you can visit the <http://www.UDDI.org> .

(B) What is DISCO ?

DISCO is the abbreviated form of Discovery. It is basically used to club or group common services together on a server and provides links to the schema documents of the services it describes may require.

(B) What is WSDL?

Web Service Description Language (WSDL) is a W3C specification which defines XML grammar for describing Web Services. XML grammar describes details such as:-

- √ Where we can find the Web Service (its URI)?
- √ What are the methods and properties that service supports?
- √ Data type support.
- √ Supported protocols

In short its a bible of what the webservice can do. Clients can consume this WSDL and build proxy objects that clients use to communicate with the Web Services. Full WSDL specification is available at <http://www.w3.org/TR/wsdl>.

(A) What the different phase/steps of acquiring a proxy object in Webservice ?

Following are the different steps needed to get a proxy object of a webservice at the client side :-

- √ Client communicates to UDDI node for WebService either through browser or UDDI's public web service.
- √ UDDI responds with a list of webservice.

-
- √ Every service listed by webservice has a URI pointing to DISCO or WSDL document.
 - √ After parsing the DISCO document, we follow the URI for the WSDL document related to the webservice which we need.
 - √ Client then parses the WSDL document and builds a proxy object which can communicate with Webservice.

(B) What is file extension of Webservices ?

.ASMX is extension for Webservices.

Note :- After this we are going to deal with a sample of webservice. In VS2005 webproject is created from the menu itself as compared to 2003 where it was present in the explorer.

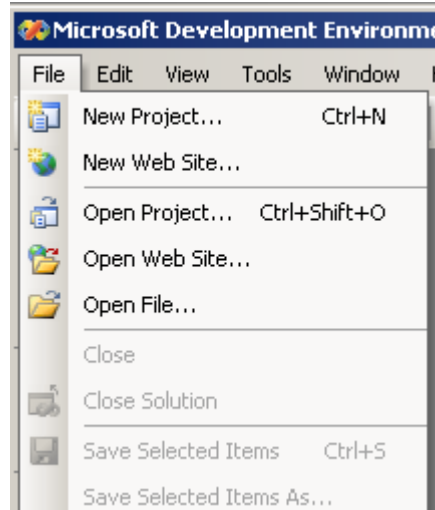

Figure :- 4.8 Create Web project menu in VS2005

(B) Which attribute is used in order that the method can be used as WebService ?

WebMethod attribute has to be specified in order that the method and property can be treated as WebService.

(A) What are the steps to create a webservice and consume it ?

Note :- For this question this book will make a attempt by creating a simple webservice and explaining steps to acheive it. A simple webservice will be created which takes two number and gives addition result of the two number. In CD sample webservice project with folder name "MathsWebService" is provided and same will be explained below. Definitely the

interviewer will not expect such a detail answer but this book will explain you in detail so that you are on right track during interview.

This webservice will add two numbers and give to the calling client. All the below steps are according to VS2005 beta editor :-

- √ First create a website by clicking on File -- New WebSite.

- √ From “Visual Studio Installed Templates” click on “Asp.NET Web Service”.
See figure below. Name the figure as “Maths Web Service”.

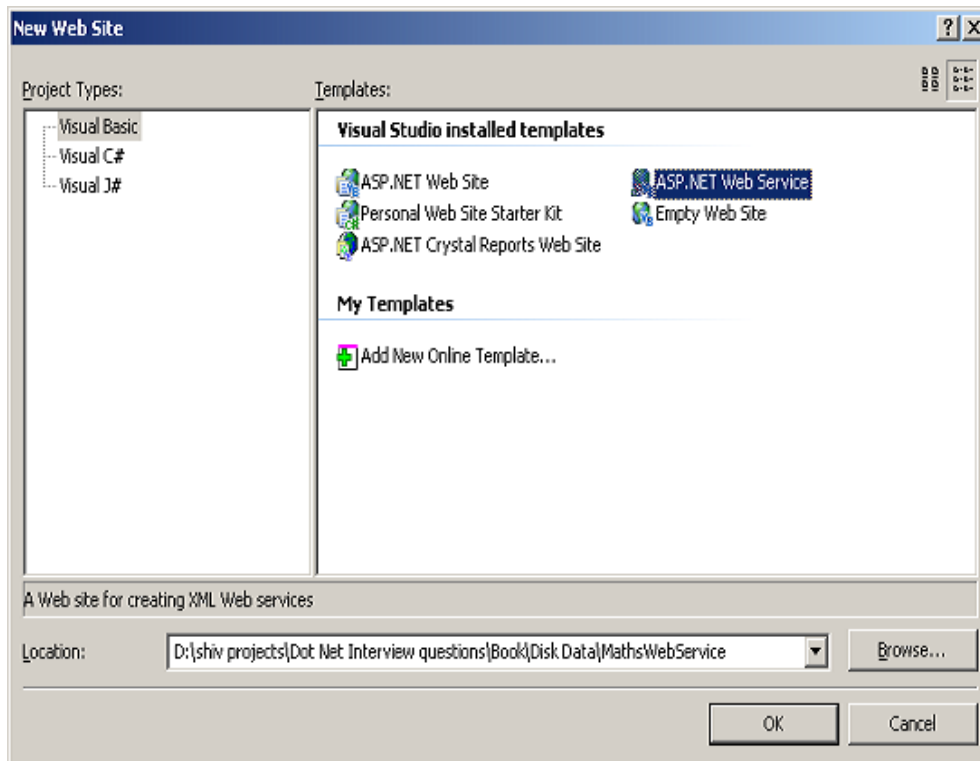

Figure :- 4.9 Create Webservice Project

- √ By default the .NET editor has made a default webservice method called as "HelloWord" which returns a string datatype. Let's rename "Service.vb" to "Maths.vb" and "Service.asmx" to "Maths.asmx". Let's replace the "HelloWorld" with following code below :-

```
<WebMethod(> _  
    Public Function AddTwoNumbers(ByVal Number1 As Integer, ByVal  
        Number2 As Integer) As Integer  
        Return Number1 + Number2
```

End Function

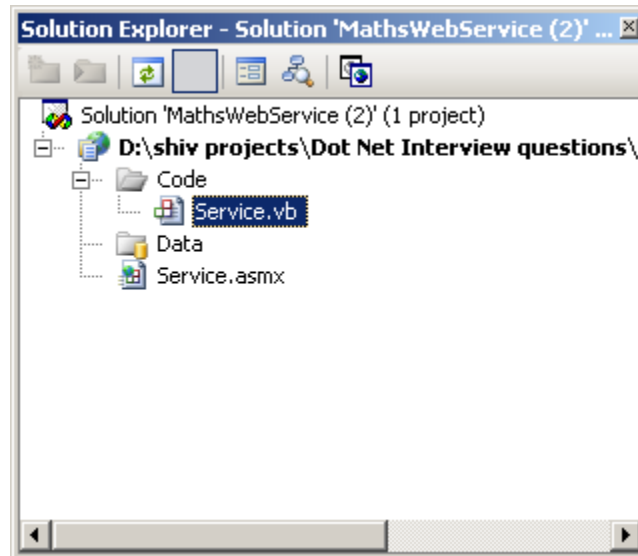

Figure :- 4.10 Rename all your default “Service” to “Maths”

- √ After the webservice is done click on add Webreference. Normally for components we do a “Add Reference” and for Webservices we do “Add Web Reference”.

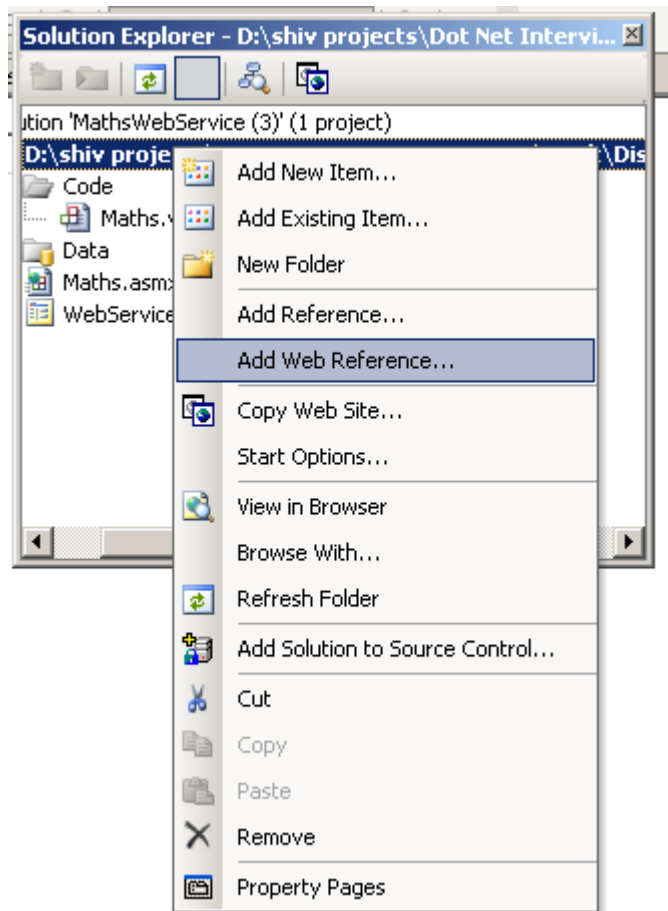

Figure :- 4.11 Click on Add Web Reference

- √ You will be shown with a list of webservices which are known to the solutions. As we are looking for our “Maths” webservice which exist in the

same solution, we click “Webservices in this solution”.

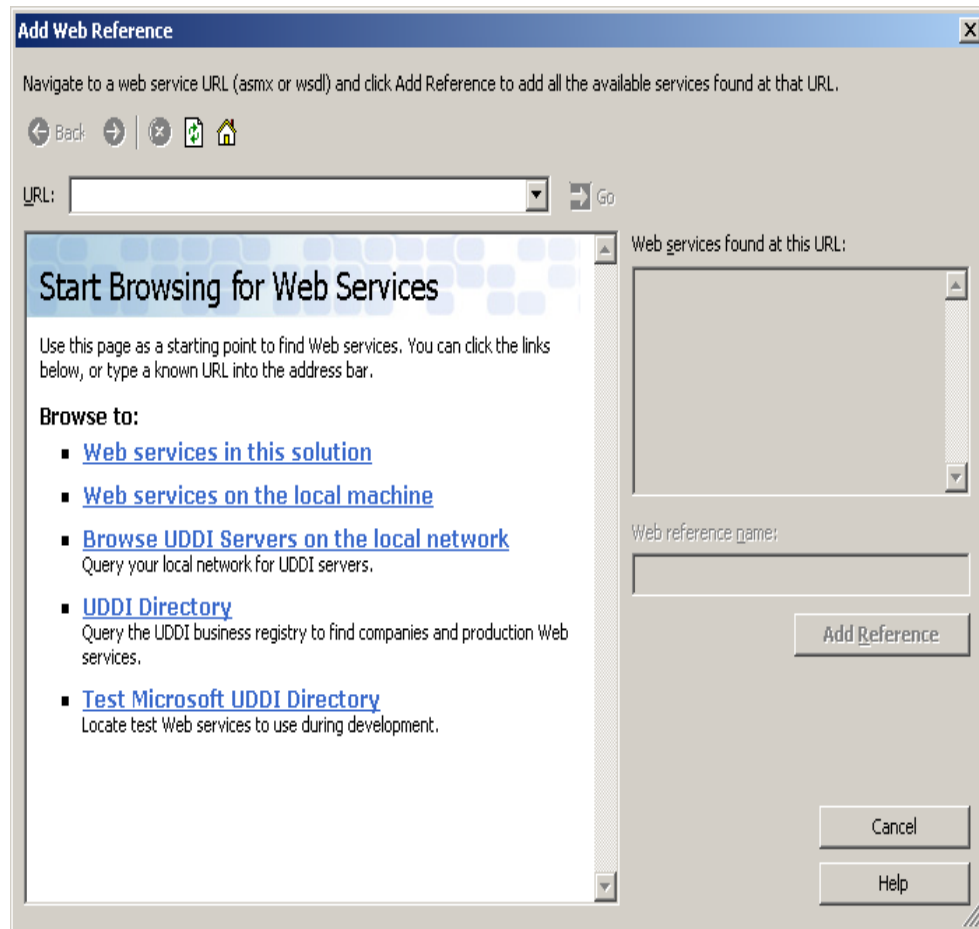

Figure :- 4.12 List of webservices for browsing

√ Your editor has located the “Maths” webservice. Select the webservice.

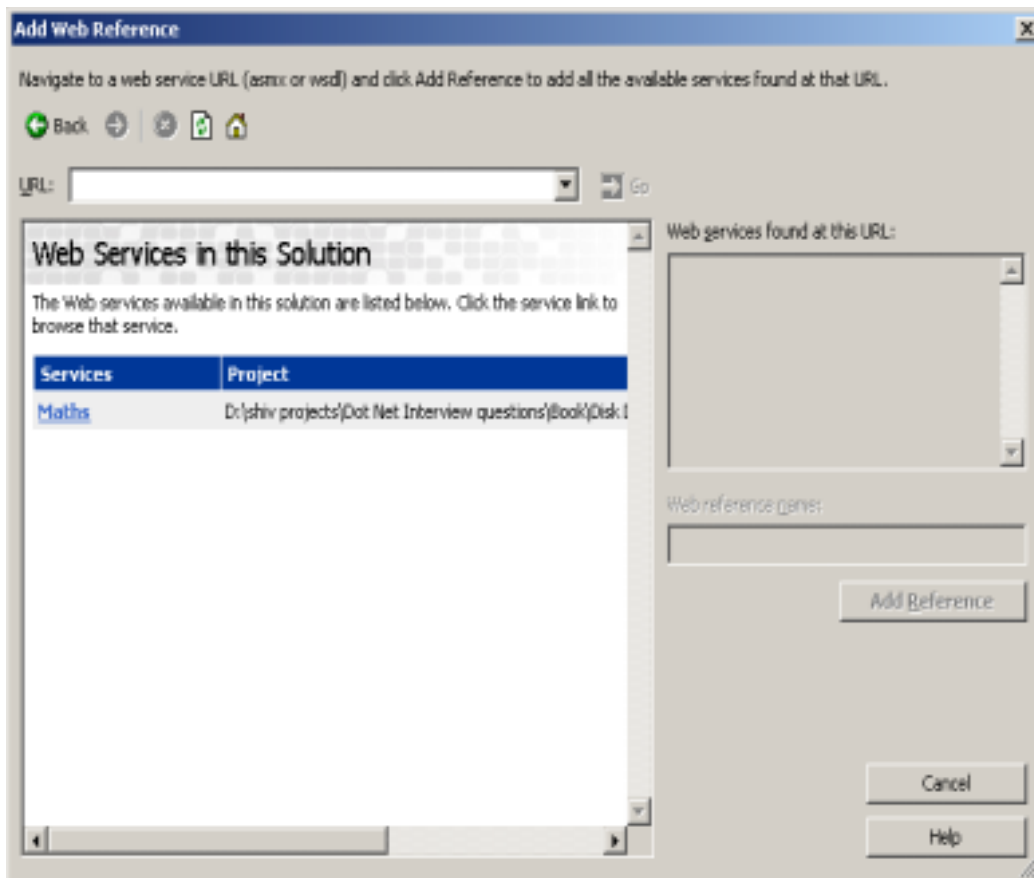

Figure :- 4.13 Solution showing the availability of Maths Webservice.

-
- √ After you have clicked on “Maths” webservice you will see a search progress bar as shown in figure below. This process will start the webservice, reference it and create a proxy for the client, so that using it client can absorb the webservice.

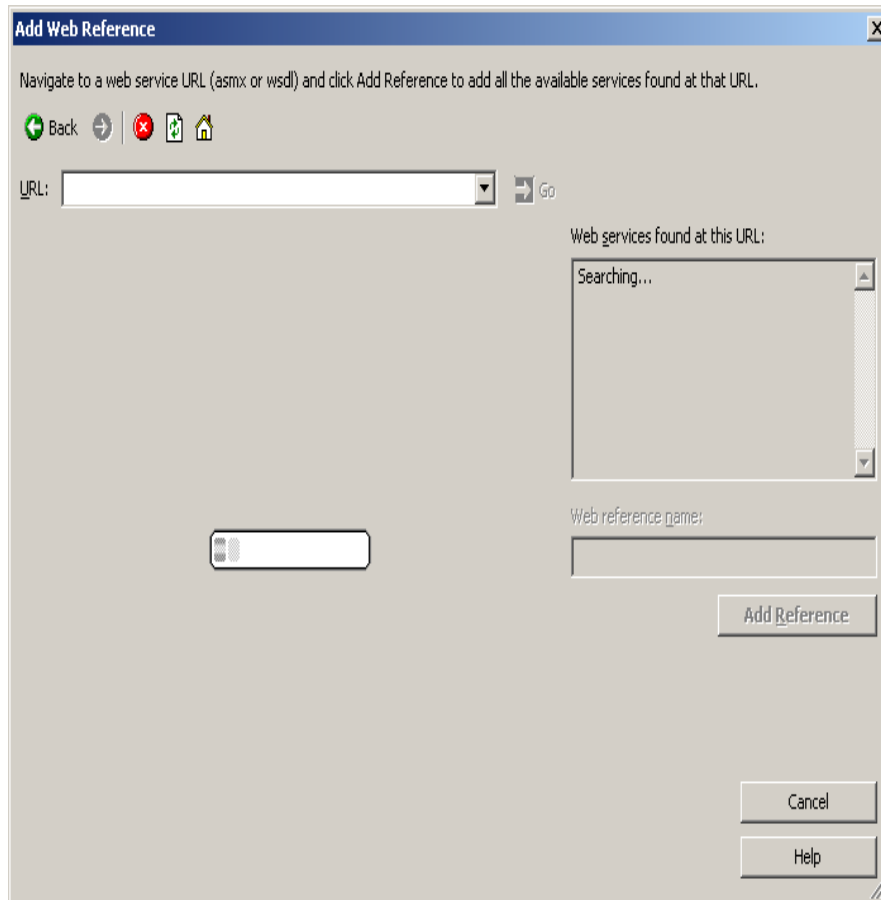

Figure :- 4.14 Starting the webservice and creating the proxy for your solution.

- √ Finally you are able to see your webservice which is ready for use. Click on Add Reference and you will see a “Localhost” reference in your .NET solution.

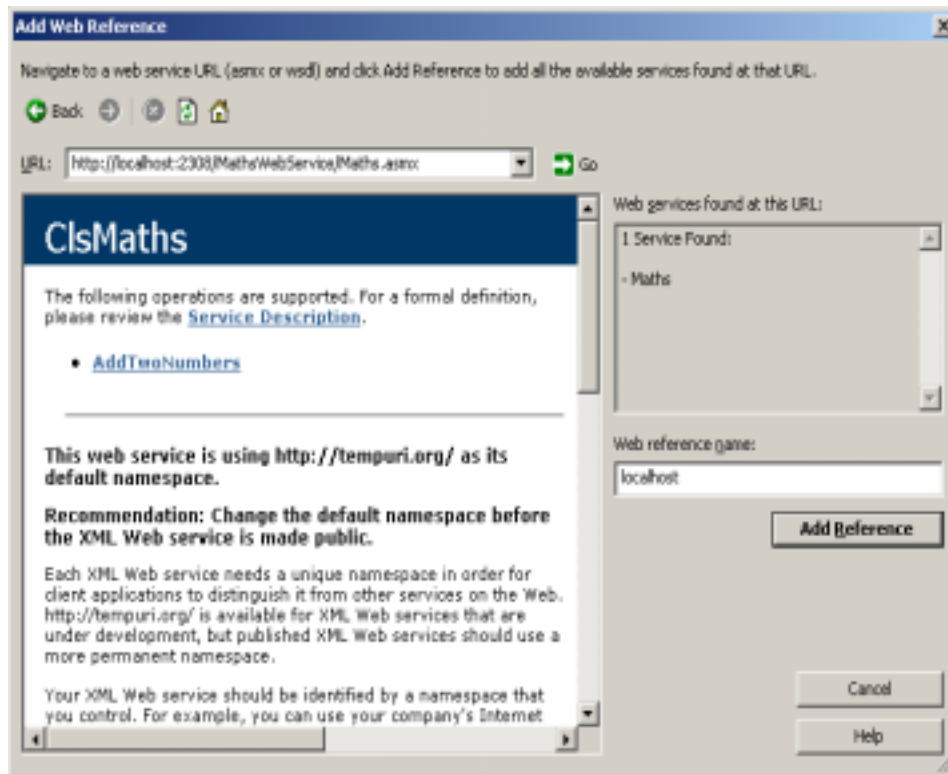

Figure :- 4.15 Starting the webservice and creating the proxy for your solution.

- √ We need to make a client who will absorb this “Maths Webservice”. Add “WebserviceClient.aspx” and create a UI as shown below. In the button click put in the following code. “LocalHost.ClsMaths” is the proxy object by which you can make calls to the webservice.

```
Sub cmdCalculate_Click(ByVal sender As Object, ByVal e As
```

```
System.EventArgs)
    Dim pObjMaths As New localhost.ClsMaths
    lblResultDisplay.Text =
Convert.ToString(pObjMaths.AddTwoNumbers(Convert.ToInt16(txtNumber1.Text),
Convert.ToInt16(txtNumber2.Text)))
End Sub
```

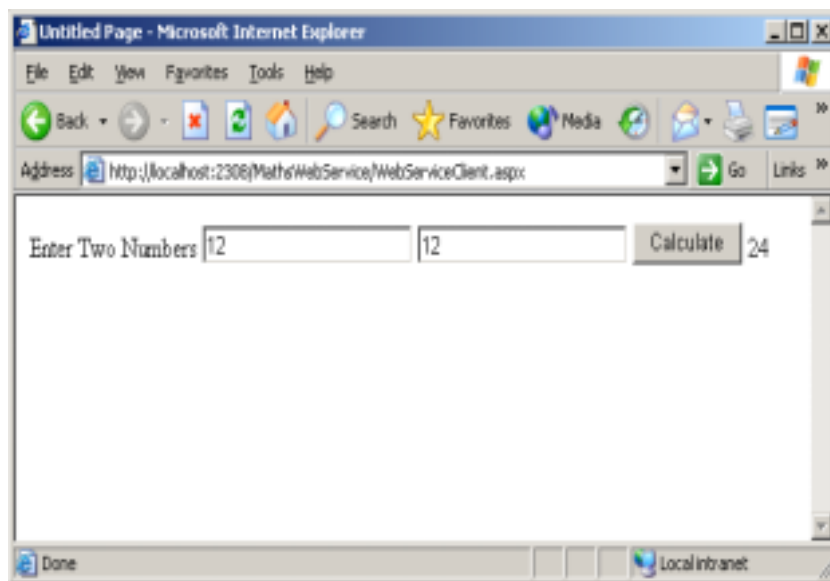

Figure :- 4.16 Complete Webservice in action.

Note :- The whole point of creating this “Maths Webservice” step by step was to have a understanding of practical angle of how webservices are created. It’s very rare that you will be asked to explain every step of how to write a webservice. But in case your interviewer is too bend down to also know what are the actual steps in creating a Webservice.

(A) Do webservice have state ?

Twist :- How can we maintain State in Webservices ?

Webservices as such do not have any mechanism by which they can maintain state. Webservices can access ASP.NET intrinsic objects like Session, application and so on if they inherit from “WebService” base class.

```
<%@ Webservice class="TestWebServiceClass" %>
Imports System.Web.Services
Public class TestWebServiceClass
    Inherits WebService

    <WebMethod> Public Sub SetSession(value As String)
        session("Val") = Value
    End Sub
end class
```

Above is a sample code which sets as session object called as “val”. TestWebserviceClass is inheriting from WebService to access the session and application objects.

5. Caching Concepts

(B) What is an application object ?

Application object can be used in situation where we want data to be shared across users globally.

(I)What's the difference between Cache object and application object ?

The main difference between the Cache and Application objects is that the Cache object provides cache-specific features, such as dependencies and expiration policies.

(I)How can get access to cache object ?

The Cache object is defined in the System.Web.Caching namespace. You can get a reference to the Cache object by using the Cache property of the HttpContext class in the System.Web namespace or by using the Cache property of the Page object.

(A)What are dependencies in cache and types of dependencies ?

When you add an item to the cache, you can define dependency relationships that can force that item to be removed from the cache under specific activities of dependencies. Example if the cache object is dependent on file and when the file data changes you want the cache object to be update. Following are the supported dependency :-

- √ File dependency :- Allows you to invalidate a specific cache item when a disk based file or files change.
- √ Time-based expiration :- Allows you to invalidate a specific cache item depending on predefined time.
- √ Key dependency :-Allows you to invalidate a specific cache item depending when another cached item changes.

(P)Can you show a simple code showing file dependency in cache ?

Partial Class Default_aspx

```
Public Sub displayAnnouncement()  
    Dim announcement As String  
    If Cache("announcement") Is Nothing Then  
        Dim file As New _  
            System.IO.StreamReader _  
                (Server.MapPath("announcement.txt"))  
        announcement = file.ReadToEnd  
        file.Close()  
        Dim depends As New _  
            System.Web.Caching.CacheDependency _  
                (Server.MapPath("announcement.txt"))  
        Cache.Insert("announcement", announcement, depends)  
    End If  
    Response.Write(CType(Cache("announcement"), String))  
End Sub  
  
Private Sub Page_Init(ByVal sender As Object, ByVal e As  
    System.EventArgs) Handles Me.Init  
    displayAnnouncement()  
End Sub  
End Class
```

Note :- Above source code can be obtained from CD in "CacheSample" folder. "Announcement.txt" is in the same folder which you can play around to see the results.

Above given method displayAnnouncement() displays banner text from Announcement.txt file which is lying in application path of the web directory. Above method first checks whether the Cache object is nothing, if the cache object is nothing then it moves further to load the cache data from the file. Whenever the file data changes the cache object is removed and set to nothing.

(A) What is Cache Callback in Cache ?

Cache object is dependent on its dependencies example file based, time based etc...Cache items remove the object when cache dependencies change.ASP.NET provides capability to execute a callback method when that item is removed from cache.

(A) What is scavenging ?

When server running your ASP.NET application runs low on memory resources, items are removed from cache depending on cache item priority. Cache item priority is set when you add item to cache. By setting the cache item priority controls the items scavenging are removed first.

(B) What are different types of caching using cache object of ASP.NET?

You can use two types of output caching to cache information that is to be transmitted to and displayed in a Web browser:

√ **Page Output Caching**

Page output caching adds the response of page to cache object. Later when page is requested page is displayed from cache rather than creating the page object and displaying it. Page output caching is good if the site is fairly static.

√ **Page Fragment Caching**

If parts of the page are changing, you can wrap the static sections as user controls and cache the user controls using page fragment caching.

(B) How can you cache different version of same page using ASP.NET cache object ?

Output cache functionality is achieved by using "OutputCache" attribute on ASP.NET page header. Below is the syntax

```
<%@ OutputCache Duration="20" Location="Server" VaryByParam="state" VaryByCustom="minorversion" VaryByHeader="Accept-Language"%>
```

- √ VaryByParam :- Caches different version depending on input parameters send through HTTP POST/GET.
- √ VaryByHeader:- Caches different version depending on the contents of the page header.

-
- √ VaryByCustom:-Lets you customize the way the cache handles page variations by declaring the attribute and overriding the GetVaryByCustomString handler.
 - √ VaryByControl:-Caches different versions of a user control based on the value of properties of ASP objects in the control.

(A) How will implement Page Fragment Caching ?

Page fragment caching involves the caching of a fragment of the page, rather than the entire page. When portions of the page are need to be dynamically created for each user request this is best method as compared to page caching. You can wrap Web Forms user control and cache the control so that these portions of the page don't need to be recreated each time.

(B)Can you compare ASP.NET sessions with classic ASP?

ASP.NET session caches per user session state. It basically uses "HttpSessionState" class.

Following are the limitations in classic ASP sessions :-

- √ ASP session state is dependent on IIS process very heavily. So if IIS restarts ASP session variables are also recycled.ASP.NET session can be independent of the hosting environment thus ASP.NET session can maintained even if IIS reboots.
- √ ASP session state has no inherent solution to work with Web Farms.ASP.NET session can be stored in state server and SQL SERVER which can support multiple server.
- √ ASP session only functions when browser supports cookies.ASP.NET session can be used with browser side cookies or independent of it.

(B) Which various modes of storing ASP.NET session ?

- √ InProc:- In this mode Session state is stored in the memory space of the Aspnet_wp.exe process. This is the default setting. If the IIS reboots or web application restarts then session state is lost.
- √ StateServer:-In this mode Session state is serialized and stored in a separate process (Aspnet_state.exe); therefore, the state can be stored on a separate computer(a state server).

-
- √ SQL SERVER:- In this mode Session state is serialized and stored in a SQL Server database.

Session state can be specified in <sessionState> element of application configuration file. Using State Server and SQL SERVER session state can be shared across web farms but note this comes at speed cost as ASP.NET needs to serialize and deserialize data over network again and again.

(A) Is Session_End event supported in all session modes ?

Session_End event occurs only in “Inproc mode”. “State Server” and “SQL SERVER” do not have Session_End event.

(A) What are the precautions you will take in order that StateServer Mode work properly ?

Following are the things to remember so that StateServer Mode works properly :-

- √ StateServer mode session data is stored in a different process so you must ensure that your objects are serializable.
- √ <machineKey> elements in Web.config should be identical across all servers. So this ensures that encryption format is same across all computers.
- √ IIS metabase (\LM\W3SVC\2) must be identical across all servers in that farm.

(A) What are the precautions you will take in order that SQLSERVER Mode work properly ?

Following are the things to remember so that SQLSERVER Mode works properly :-

- √ SQLSERVER mode session data is stored in a different process so you must ensure that your objects are serializable.
- √ IIS metabase (\LM\W3SVC\2) must be identical across all servers in that farm.
- √ By default Session objects are stored in “Tempdb”, you can configure it store outside “TempDB” by running Microsoft provided SQL script.

Note :- "TempDB" database is re-created after SQL SERVER computer reboot.If you want to maintain session state with every reboot best is to run SQL Script and store session objects outside "TempDB" database.

(A) Where do you specify session state mode in ASP.NET ?

```
<sessionState mode="SQLServer"
stateConnectionString="tcpip=192.168.1.1:42424"
sqlConnectionString="data source=192.168.1.1; Integrated
Security=SSPI"
cookieless="false"
timeout="20"
/>
```

Above is sample session state mode specified for SQL SERVER.

(B) What are the other ways you can maintain state ?

Other than session variables you can use the following technique to store state :

- √ Hidden fields
- √ View state
- √ Hidden frames
- √ Cookies
- √ Query strings

(B) What are benefits and Limitation of using Hidden fields ?

Following are the benefits of using Hidden fields :-

- √ They are simple to implement.
- √ As data is cached on client side they work with Web Farms.
- √ All browsers support hidden field.
- √ No server resources are required.

Following are limitations of Hidden field :-

- √ They can be tampered creating a security hole.

-
- √ Page performance decreases if you store large data, as the data are stored in pages itself.
 - √ Hidden fields do not support rich structures as HTML hidden fields are only single valued. Then you have to work around with delimiters etc to handle complex structures.

Below is how you will actually implement hidden field in a project

```
<input id="HiddenValue" type="hidden" value="Initial Value"
runat="server"NAME="HiddenValue">
```

(B) What is ViewState ?

Viewstate is a built-in structure for automatically retaining values amongst the multiple requests for the same page. The viewstate is internally maintained as a hidden field on the page but is hashed, providing greater security than developer-implemented hidden fields do.

(A) Does the performance for viewstate vary according to User controls ?

Performance of viewstate varies depending on the type of server control to which it is applied. Label, TextBox, CheckBox, RadioButton, and HyperLink are server controls that perform well with ViewState. DropDownList, ListBox, DataGrid, and DataList suffer from poor performance because of their size and the large amounts of data making roundtrips to the server.

(B) What are benefits and Limitation of using Viewstate for state management?

Following are the benefits of using Viewstate :-

- √ No server resources are required because state is in a structure in the page code.
- √ Simplicity.
- √ States are retained automatically.

- √ The values in view state are hashed, compressed, and encoded, thus representing a higher state of security than hidden fields.
- √ View state is good for caching data in Web frame configurations because the data is cached on the client.

Following are limitation of using Viewstate:-

- √ Page loading and posting performance decreases when large values are stored because view state is stored in the page.
- √ Although view state stores data in a hashed format, it can still be tampered because it is stored in a hidden field on the page. The information in the hidden field can also be seen if the page output source is viewed directly, creating a potential security risk.

Below is sample of storing values in view state.

```
this.ViewState["EnterTime"] = DateTime.Now.ToString();
```

(B) How can you use Hidden frames to cache client data ?

This technique is implemented by creating a Hidden frame in page which will contain your data to be cached.

```
<FRAMESET cols="100%,*,*">
<FRAMESET rows="100%">
<FRAME src="data_of_frame1.html"></FRAMESET>
<FRAME src="data_of_hidden_frame.html">
<FRAME src="data_of_hidden_frame.html" frameborder="0" noresize
scrolling="yes">
</FRAMESET>
```

Above is a sample of hidden frames where the first frame “data_of_frame1.html” is visible and the remaining frames are hidden by giving whole col section to first frame. See allocation where 100 % is allocated to first frame and remaining frames thus remain hidden.

(I) What are benefits and limitations of using Hidden frames?

Following are the benefits of using hidden frames:

- √ You can cache more than one data field.
- √ The ability to cache and access data items stored in different hidden forms.
- √ The ability to access JScript® variable values stored in different frames if they come from the same site.

The limitations of using hidden frames are:

- √ Hidden frames are not supported on all browsers.
- √ Hidden frames data can be tampered thus creating security hole.

(I) What are benefits and limitations of using Cookies?

Following are benefits of using cookies for state management :-

- √ No server resources are required as they are stored in client.
- √ They are light weight and simple to use

Following are limitation of using cookies :-

- √ Most browsers place a 4096-byte limit on the size of a cookie, although support for 8192-byte cookies is becoming more common in the new browser and client-device versions available today.
- √ Some users disable their browser or client device's ability to receive cookies, thereby limiting the use of cookies.
- √ Cookies can be tampered and thus creating a security hole.
- √ Cookies can expire thus leading to inconsistency.

Below is sample code of implementing cookies

```
Request.Cookies.Add(New HttpCookie("name", "user1"))
```

(I) What is Query String and What are benefits and limitations of using Query Strings?

A query string is information sent to the server appended to the end of a page URL.

Following are the benefits of using query string for state management:-

-
- √ No server resources are required. The query string containing in the HTTP requests for a specific URL.
 - √ All browsers support query strings.

Following are limitations of query string :-

- √ Query string data is directly visible to user thus leading to security problems.-
- √ Most browsers and client devices impose a 255-character limit on URL length.

Below is a sample “Login” query string passed in URL <http://www.querystring.com/login.asp?login=testing>. This query string data can then be requested later by using `Request.QueryString(“login”)`.

(I) What is Absolute and Sliding expiration?

Absolute Expiration allows you to specify the duration of the cache, starting from the time the cache is activated. The following example shows that the cache has a cache dependency specified, as well as an expiration time of one minute.

```
Cache.Insert("announcement", announcement, depends, _  
DateTime.Now.AddMinutes(1), Nothing)
```

Sliding Expiration specifies that the cache will expire if a request is not made within a specified duration. Sliding expiration policy is useful whenever you have a large number of items that need to be cached, because this policy enables you to keep only the most frequently accessed items in memory. For example, the following code specifies that the cache will have a sliding duration of one minute. If a request is made 59 seconds after the cache is accessed, the validity of the cache would be reset to another minute:

```
Cache.Insert("announcement", announcement, depends, _  
DateTime.MaxValue, _  
TimeSpan.FromMinutes(1))
```

(I)What is cross page posting?

Note :- This is a new feature in ASP.NET 2.0

By default, button controls in ASP.NET pages post back to the same page that contains the button, where you can write an event handler for the post. In most cases this is the desired behavior, but occasionally you will also want to be able to post to another page in your application. The `Server.Transfer` method can be used to move between pages, however the URL doesn't change. Instead, the cross page posting feature in ASP.NET 2.0 allows you to fire a normal post back to a different page in the application. In the target page, you can then access the values of server controls in the source page that initiated the post back.

To use cross page posting, you can set the `PostBackUrl` property of a `Button`, `LinkButton` or `ImageButton` control, which specifies the target page. In the target page, you can then access the `PreviousPage` property to retrieve values from the source page. By default, the `PreviousPage` property is of type `Page`, so you must access controls using the `FindControl` method. You can also enable strongly-typed access to the source page by setting the `@PreviousPageType` directive in the target page to the virtual path or Type name of the source page.

Here is a step-by-step guide for implementing the cross-page post back using controls that implement the `IButtonControl` interface.

- √ Create a Web Form and insert a `Button` control on it using the VS .NET designer.
- √ Set the button's `PostBackUrl` property to the Web Form you want to post back. For instance in this case it is "nextpage.aspx"

```
<asp:Button ID="Button1" runat="server"
    PostBackUrl="~/nextpage.aspx" Text="Post to nextpage" />
```

When the `PostBackUrl` property of the `IButtonControl` is set, the ASP.NET framework binds the corresponding HTML element to new JavaScript function named `WebForm_DoPostBackWithOptions`. The corresponding HTML rendered by the ASP.NET 2.0 will look like this:

```
<input type="submit" name="Button1" value="Post to Page 2"
onclick="javascript:WebForm_DoPostBackWithOptions(new
WebForm_PostBackOptions("Button1", ",false", "Page2.aspx", false, false))"
id="Button1" />
```

How do we access viewstate value of this page in the next page ?

View state is page specific; it contains information about controls embedded on the particular page. ASP.NET 2.0 resolves this by embedding a hidden input field name, `__POSTBACK` . This field is embedded only when there is an `IButtonControl` on the page and its `PostBackUrl` property is set to a non-null value. This field contains the view state information of the poster page. To access the view state of the poster page, you can use the new `PreviousPage` property of the page:

```
Page poster = this.PreviousPage;
```

Then you can find any control from the previous page and read its state:

```
Label posterLabel = poster.FindControl("myLabel");  
string lbl = posterLabel.Text;
```

This cross-page post back feature also solves the problem of posting a Form to multiple pages, because each control, in theory, can point to different post back URL.

Can we post and access view state in another application?

You can post back to any page and pages in another application, too. But if you are posting pages to another application, the `PreviousPage` property will return null. This is a significant restriction, as it means that if you want to use the view state, you are confined, for example, posting to pages in the same virtual directory. Even so, this is a highly acceptable addition to the functionality of ASP.NET.

What is SQL Cache Dependency in ASP.NET 2.0?

SQL cache dependencies is a new feature in ASP.NET 2.0 which can automatically invalidate a cached data object (such as a `Dataset`) when the related data is modified in the database. So for instance if you have a dataset which is tied up to a database tables any changes in the database table will invalidate the cached data object which can be a dataset or a data source.

How do we enable SQL Cache Dependency in ASP.NET 2.0?

Below are the broader steps to enable a SQL Cache Dependency:-

-
- Enable notifications for the database.
 - Enable notifications for individual tables.
 - Enable ASP.NET polling using “web.config” file
 - Finally use the Cache dependency object in your ASP.NET code

Enable notifications for the database.

Before you can use SQL Server cache invalidation, you need to enable notifications for the database. This task is performed with the `aspnet_regsql.exe` command-line utility, which is located in the `c:\[WinDir]\Microsoft.NET\Framework\[Version]` directory.

```
aspnet_regsql -ed -E -d Northwind
```

-ed :- command-line switch

-E: - Use trusted connection

-S: - Specify server name if other than the current computer you are working on

-d: - Database Name

So now let's try to understand what happens in the database because of “aspnet_regsql.exe”. After we execute the “aspnet_regsql -ed -E -d Northwind” command you will see one new table and four new stored procedures created.

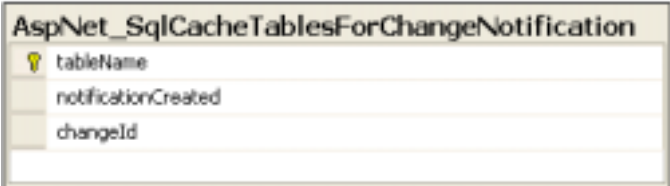

AspNet_SqlCacheTablesForChangeNotification	
tableName	
notificationCreated	
changeId	

Figure 5.1 : - SQL Cache table created for notification

Essentially, when a change takes place, a record is written in this table. The SQL Server polling queries this table for changes.

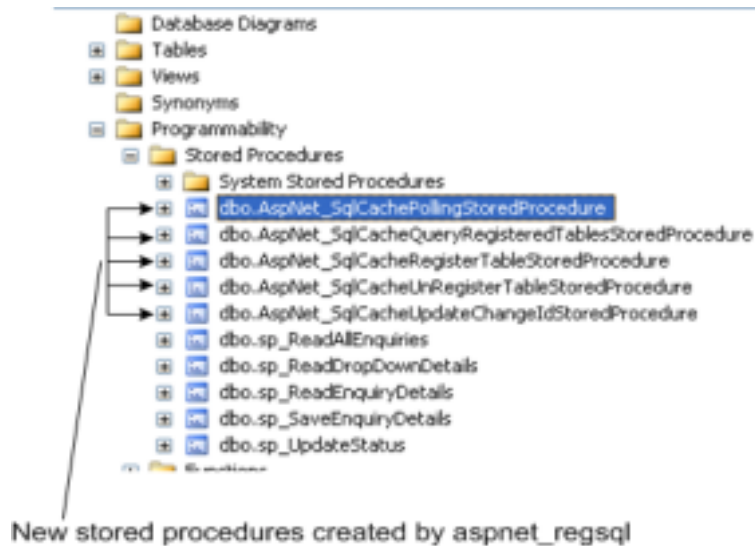

Figure 5.2 : - New stored procedures created

Just to make brief run of what the stored procedures do.

“AspNet_SqlCacheRegisterTableStoredProcedure” :- This stored procedure sets a table to support notifications. This process works by adding a notification trigger to the table, which will fire when any row is inserted, deleted, or updated.

“AspNet_SqlCacheUnRegisterTableStoredProcedure”:- This stored procedure takes a registered table and removes the notification trigger so that notifications won't be generated.

“AspNet_SqlCacheUpdateChangeIdStoredProcedure”:- The notification trigger calls this stored procedure to update the AspNet_SqlCacheTablesForChangeNotification table, thereby indicating that the table has changed.

AspNet_SqlCacheQueryRegisteredTablesStoredProcedure :- This extracts just the table names from the AspNet_SqlCacheTablesForChangeNotification table. It's used to get a quick look at all the registered tables.

AspNet_SqlCachePollingStoredProcedure :- This will get the list of changes from the AspNet_SqlCacheTablesForChangeNotification table. It is used to perform polling.

Enabling notification for individual tables

Once the necessary stored procedure and tables are created then we have to notify saying which table needs to be enabled for notifications.

That can be achieved by two ways:-

√ aspnet_regsql -et -E -d Northwind -t Products

√ Exec spNet_SqlCacheRegisterTableStoredProcedure 'TableName'

Registering tables for notification internally creates trigger for the tables. For instance for a “products” table the following trigger is created. So any modifications done to the “Products” table will update the “AspNet_SqlCacheNotification” table.

```
CREATE TRIGGER  
dbo.[Products_AspNet_SqlCacheNotification_Trigger] ON  
[Products]  
FOR INSERT, UPDATE, DELETE  
AS  
BEGIN  
SET NOCOUNT ON  
EXEC dbo.AspNet_SqlCacheUpdateChangeIdStoredProcedure  
N'Products'  
END
```

“AspNet_SqlCacheTablesForChangeNotification” contains a single record for every table you're monitoring. When you make a change in the table (such as inserting, deleting or updating a record), the change Id column is incremented by 1. ASP.NET queries this table repeatedly keeps track of the most recent changed values for every table. When this value changes in a subsequent read, ASP.NET knows that the table has changed.

Table - dbo.Asp...ngeNotification		Table - dbo.AppUser	
	tableName	notificationCreated	changeId
▶	Appuser	2/1/2006 6:23:20 PM	3
*	NULL	NULL	NULL

Shows that "AppUser" table data has changed

Figure 5.3 : - Entries in the Cache notification table

Enable ASP.NET polling using "web.config" file

Now that all our database side is configured in order to get the SQL Cache working in the ASP.NET side we need to do some configuration in the web.config file.

We need to set two attributes in the "web.config" file:-

- √ Set "Enabled" attribute to true to set the caching on.
- √ Set the poll time attribute to the number of milliseconds between each poll

Below is the snapshot of the web.config file.

```

<configuration>
  <connectionStrings>
    <addname="Northwind"
    connectionString="server=localhost;database=Northwind;UID=sa;PWD="/>
  </connectionStrings>
  <system.web>
    <caching>
      <sqlCacheDependency enabled="true" pollTime="1000" >
        <databases>
          <add name="NorthWind" connectionStringName="Pubs" />
        </databases>
      </sqlCacheDependency>
    </caching>
  </system.web>

```

Enable the
Cachdependency
functionality

Number of milliseconds
between each poll

Figure 5.4 :- Web.config file modifications for SQL cache

Finally use the Cache dependency object in your ASP.NET code

Now comes the final step to use our cache dependency with programmatic data caching, a data source control, and output caching.

For programmatic data caching, we need to create a new `SqlCacheDependency` and supply that to the `Cache.Insert()` method. In the `SqlCacheDependency` constructor, you supply two strings. The first is the name of the database you defined in the element in the section of the web.config file e.g: Northwind. The second is the name of the linked table e.g: Products.

```
private static void CacheProductsList(List<ClsProductItem> products)
{
    SqlCacheDependency sqlDependency = new SqlCacheDependency("Northwind",
    "Products");

    HttpContext.Current.Cache.Insert("ProductsList", products, sqlDependency,
    DateTime.Now.AddDays(1), Cache.NoSlidingExpiration);}

private static List<ClsProductItem> GetCachedProductList()
{
    return HttpContext.Current.Cache["ProductsList"] as List<ClsProductItem>;}
```

`ClsProductItem` is business class, and here we are trying to cache a list of `ClsProductItem` instead of `DataSet` or `DataTable`.

The following method is used by an `ObjectDataSource` Control to retrieve List of Products

```
public static List<ClsProductItem> GetProductsList(int catId, string sortBy)
{
    //Try to Get Products List from the Cache
    List<ClsProductItem> products = GetCachedProductList();
    if (products == null)
    {
        //Products List not in the cache, so query the Database layer
        ClsProductsDB db = new ClsProductsDB(_connectionString);
        DbDataReader reader = null;
        products = new List<ClsProductItem>(80);
```

```
if (catId > 0)
{
//Return Product List from the Data Layer
reader = db.GetProductsList(catId);
}
else
{
//Return Product List from the Data Layer
reader = db.GetProductsList();
}
//Create List of Products -List if ClsProductItem-
products = BuildProductsList(reader);
reader.Close();

//Add entry to products list in the Cache
CacheProductsList(products);

}
products.Sort(new ClsProductItemComparer(sortBy));

if (sortBy.Contains("DESC")) products.Reverse();
return products;

}
```

To perform the same trick with output caching, you simply need to set the `SqlDependency` property with the database dependency name and the table name, separated by a colon:

```
<%@ OutputCache Duration="600" SqlDependency="Northwind:Products"
    VaryByParam="none" %>
```

The same technique works with the `SqlDataSource` and `ObjectDataSource` controls:

```
<asp:SqlDataSource                                EnableCaching="True"
    SqlCacheDependency="Northwind:Products" ... />
```

Note :- ObjectDataSource doesn't support built in caching for Custom types such as the one in our example. It only supports this feature for DataSets and DataTables.

Just to make a sample check run the SQL Server profiler and see that does the SQL actually hit the database after the first run.

What is Post Cache substitution?

Post cache substitution is used when we want to cache the whole page but also need some dynamic region inside that cached page. Some examples like `QuoteoftheDay`, `RandomPhotos`, and `AdRotator` etc. are examples where we can implement Post Cache Substitution.

Post-cache substitution can be achieved by two means:

- √ Call the new `Response.WriteSubstitution` method, passing it a reference to the desired substitution method callback.
- √ Add a `<asp:Substitution>` control to the page at the desired location, and set its `methodName` attribute to the name of the callback method.

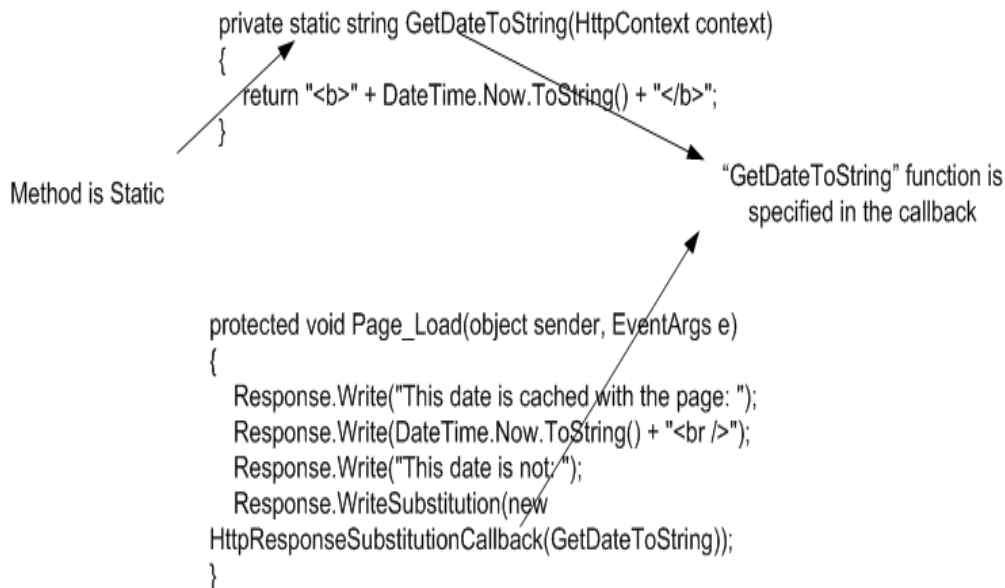

Figure 5.5 : - "Writesubstitution" in action

You can see we have a static function here "GetDateToString()". We pass the response substitution callback to the "WriteSubstitution" method. So now when ASP.NET page framework retrieves the cached page, it automatically triggers your callback method to get the dynamic content. It then inserts your content into the cached HTML of the page. Even if your page hasn't been cached yet (for example, it's being rendered for the first time), ASP.NET still calls your callback in the same way to get the dynamic content. So you create a method that generates some dynamic content, and by doing so you guarantee that your method is always called, and its content is never cached.

Ok the above example was by using "WriteSubstitution" now lets try to see how we can do by using "<asp:substitution>" control. You can get the "<asp:substitution>" control from the editor toolbox.



Figure 5.6 : - Substitution Control

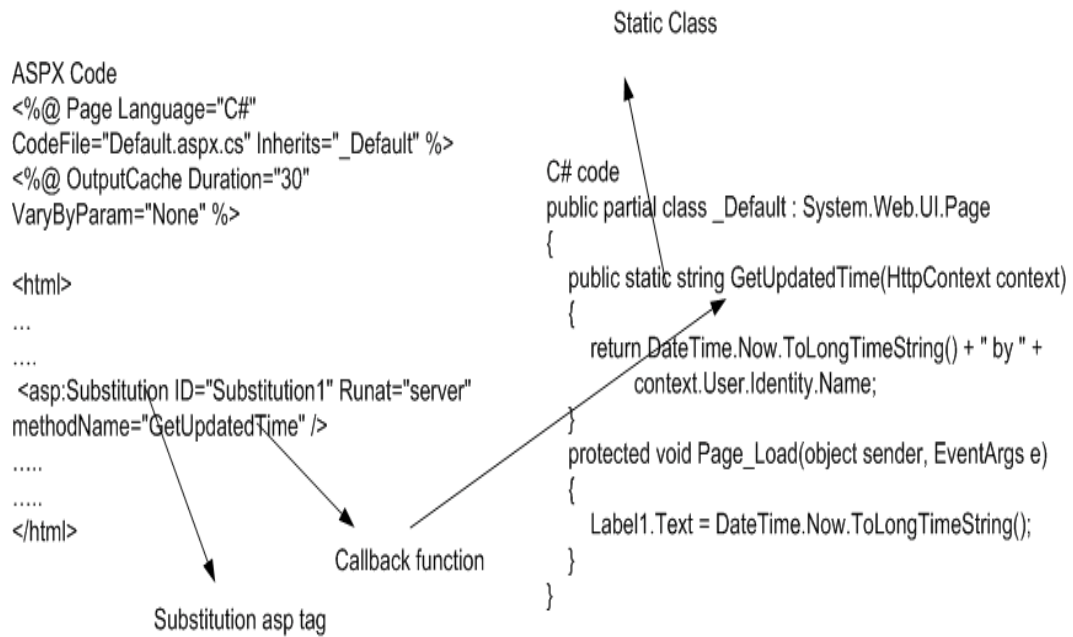

Figure 5.7 : - Substitution in Action.

Below is a sample code which shows how substitution control works. We have ASPX code at the right hand side and class code at the behind code at the left hand side. We need to provide the method name in the “methodname” attribute of the substitution control.

Why do we need methods to be static for Post Cache substitution?

ASP.NET should be able to call this method even when there isn't an instance of your page class available. When your page is served from the cache, the page object isn't created. So ASP.NET skips the page life cycle when the page is coming from cache, which means it won't create any control objects or raise any control events. If your dynamic content depends on the values of other controls, you'll need to use a different technique, because these control objects won't be available to your callback

6 . OOPS

(B) What is Object Oriented Programming ?

It is a problem solving technique to develop software systems. It is a technique to think real world in terms of objects. Object maps the software model to real world concept. These objects have responsibilities and provide services to application or other objects.

(B) What's a Class ?

A class describes all the attributes of objects, as well as the methods that implement the behavior of member objects. It's a comprehensive data type which represents a blue print of objects. It's a template of object.

(B) What's an Object ?

It is a basic unit of a system. An object is an entity that has attributes, behavior, and identity. Objects are members of a class. Attributes and behavior of an object are defined by the class definition.

(A) What is the relation between Classes and Objects ?

They look very much same but are not same. Class is a definition, while object is a instance of the class created. Class is a blue print while objects are actual objects existing in real world. Example we have class CAR which has attributes and methods like Speed, Brakes, Type of Car etc. Class CAR is just a prototype, now we can create real time objects which can be used to provide functionality. Example we can create a Maruti car object with 100 km speed and urgent brakes.

(B) What are different properties provided by Object-oriented systems ?

Twist :- Can you explain different properties of Object Oriented Systems?

Note:- Difference between abstraction and encapsulation is one of the favorite interview question and quiet confusing as both the terminology look alike. Best is if you can brainstorm with your friends or do a little reading

Following are characteristic's of Object Oriented System's :-

Abstraction

It allows complex real world to be represented in simplified manner. Example color is abstracted to RGB. By just making the combination of these three colors we can achieve any color in world. It's a model of real world or concept.

Encapsulation

It is a process of hiding all the internal details of an object from the outside world.

Communication using messages

When application wants to achieve certain task it can only be done using combination of objects. A single object can not do all the task. Example if we want to make order processing form. We will use Customer object, Order object, Product object and Payment object to achieve this functionality. In short these objects should communicate with each other. This is achieved when objects send messages to each other.

Object lifetime

All objects have life time. Objects are created, and initialized, necessary functionalities are done and later the object is destroyed. Every object has their own state and identity which differ from instance to instance.

Class hierarchies (Inheritance and aggregation)

Twist :- What is difference between Association, Aggregation and Inheritance relationships?

In object oriented world objects have relation and hierarchies in between them. There are basically three kind of relationship in Object Oriented world :-

Association

This is the simplest relationship between objects. Example every customer has sales. So Customer object and sales object have an association relation between them.

Aggregation

This is also called as composition model. Example in order to make a "Accounts" class it has use other objects example "Voucher", "Journal" and "Cash" objects. So accounts class is aggregation of these three objects.

Inheritance

Hierarchy is used to define more specialized classes based on a preexisting generalized class. Example we have VEHICLE class and we can inherit this class make more specialized class like CAR, which will add new attributes and use some existing qualities of the parent class. It shows more of a parent-child relationship. This kind of hierarchy is called inheritance.

Polymorphism

When inheritance is used to extend a generalized class to a more specialized class, it includes behavior of the top class (Generalized class). The inheriting class often implements a behavior that can be somewhat different than the generalized class, but the name of the behavior can be the same. It is important that a given instance of an object use the correct behavior, and the property of polymorphism allows this to happen automatically.

(B) How can we achieve inheritance in VB.NET ?

Note:- The following explanation is for VB.NET

Inheritance is achieved by using “Inherits” keyword in VB.NET (For C# it is “:”). Simple Sample is provided in CD for understanding inheritance in folder “WindowsApplicationInheritance”. There are two classes one is the parent “ClsParent” and second is the child “ClsChild”. Parent class has a string which has to be parsed for junk data “@” and “/”. ClsParent has the functionality which parses only cleans up “@”. ClsChild then inherits from parent and adds extra functionality by parsing “/”.

```
Public Class ClsParent
    Protected strData As String = "jksdhkj@dadad///ajkdhsjakd"
    Public Function Parse() As String
        Dim PstrData As String
        PstrData = strData
        PstrData = Replace(PstrData, "@", "")
        Return PstrData
    End Function
    Public Function GetActualString() As String
        Return strData
    End Function
End Class
```

Above is the source which parses only “@” of strData variable.

```

Public Class ClsChild
    Inherits ClsParent

    ' this is child and a special parse function is added which will
    also parse "/"
    Public Function ParseBackSlash()
        Dim PstrData As String
        PstrData = Me.Parse()
        PstrData = Replace(PstrData, "/", "")
        Return PstrData
    End Function
End Class

```

Above is the source code for “ClsChild” which does the remaining work. It adds extra functionality by parsing “/” junk character’s of the data.

Note:- Strdata was accessible only because it was defined as protected in the parent class.

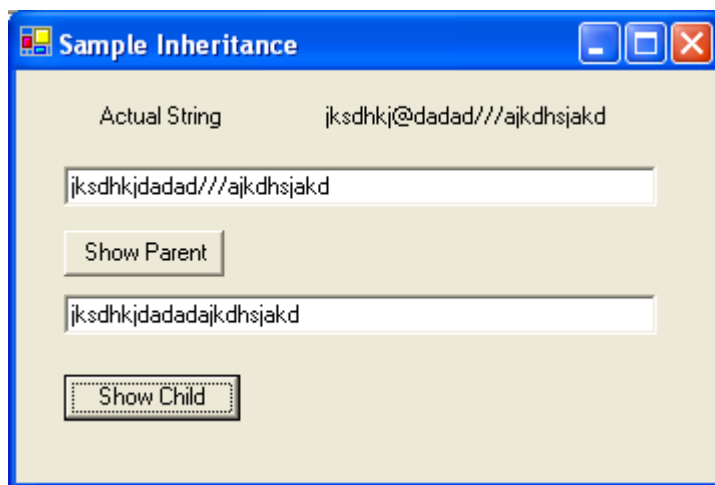

Figure :- 6.1 Inheritance in action

(I) What are abstract classes ?

Following are features of a abstract class :-

- √ You can not create a object of abstract class

-
- √ Abstract class is designed to act as a base class (to be inherited by other classes). Abstract class is a design concept in program development and provides a base upon which other classes are built.
 - √ Abstract classes are similar to interfaces. After declaring an abstract class, it cannot be instantiated on its own, it must be inherited.
 - √ In VB.NET abstract classes are created using “MustInherit” keyword. In C# we have “Abstract” keyword.
 - √ Abstract classes can have implementation or pure abstract methods which should be implemented in the child class.

Note:- In order to understand the concept simple sample of add and multiply functionality is implemented in “WindowsAbstract” folder in CD.

From interview point of view just saying using “MustInherit” keyword is more than enough to convince that you have used abstract classes. But to clear simple fundamental let’s try to understand the sample code. There are two classes one is “ClsAbstract” class and other is “ClsChild” class. “ClsAbstract” class is a abstract class as you can see the mustinherit keyword. It has one implemented method “Add” and other is abstract method which has to be implemented by child class “MultiplyNumber”. In the child class we inherit the abstract class and implement the multiplynumber function.

Definitely this sample does not take out actually how things are implemented in live projects. Basically you put all your common functionalities or half implemented functionality in parent abstract class and later let child class define the full functionality of the abstract class. Example i always use abstract class with all my SET GET properties of object in abstract class and later make specialize classes for insert, update, delete for the corresponding entity object.

```
Public MustInherit Class ClsAbstract
    ' use the mustinherit class to declare the class as abstract
    Public Function Add(ByVal intnum1 As Integer, ByVal intnum2 As
Integer) As Integer
        Return intnum1 + intnum2
    End Function
    ' left this seconf function to be completed by the inheriting
class
    Public MustOverride Function MultiplyNumber(ByVal intnum1 As
Integer, ByVal intnum2 As Integer) As Integer
End Class
```

```
Public Class ClsChild
    Inherits ClsAbstract
    ' class child overrides the MultiplyNumber function
    Public Overrides Function MultiplyNumber(ByVal intnum1 As
Integer, ByVal intnum2 As Integer) As Integer
        Return intnum1 * intnum2
    End Function
End Class
```

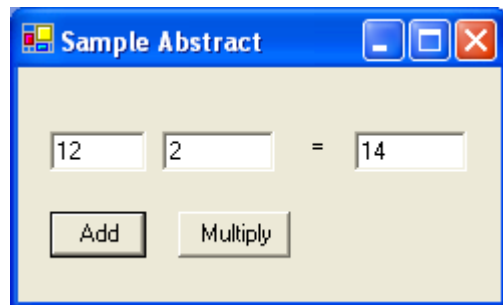

Figure :- 6.2 Abstract classes in action

My attitude towards abstract class has been that i put all my common functionality in abstract class.

(B) What is a Interface ?

Interface is a contract that defines the signature of the functionality. So if a class is implementing a interface it says to the outer world, that it provides specific behavior. Example if a class is implementing IDisposable interface that means it has a functionality to release unmanaged resources. Now external objects using this class know that it has contract by which it can dispose unused unmanaged objects.

- √ Single Class can implement multiple interfaces.
- √ If a class implements a interface then it has to provide implementation to all its methods.

Note:- In CD sample “WindowsInterFace” is provided, which has a simple interface implemented.

In sample there are two files. One has the interface definition and other class implements the interface. Below is the source code “IInterface” is the interface and “ClsDoSomething” implements the “IInterface”. This sample just displays a simple message box.

```
Public Interface IInterface
    Sub DoSomething()
End Interface

Public Class ClsDoSomething
    Implements IInterface
    Public Sub DoSomething() Implements
WindowsInterFace.IInterface.DoSomething
        MsgBox("Interface implemented")
    End Sub
End Class
```

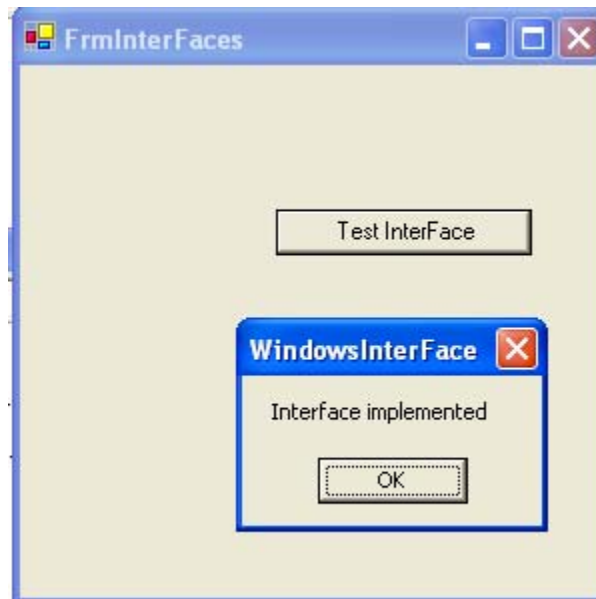

Figure:- 6.3 Interface in action

(A) What is difference between abstract classes and interfaces?

Following are the differences between abstract and interfaces :-

- √ Abstract classes can have concrete methods while interfaces have no methods implemented.
- √ Interfaces do not come in inheriting chain, while abstract classes come in inheritance.

(B) What is a delegate ?

Delegate is a class that can hold a reference to a method or a function. Delegate class has a signature and it can only reference those methods whose signature is compliant with the class. Delegates are type-safe functions pointers or callbacks.

Below is a sample code which shows a example of how to implement delegates.

```
Public Class FrmDelegates
    Inherits System.Windows.Forms.Form
    Public Delegate Sub DelegateAddString()
    Private Sub FrmDelegates_Load(ByVal sender As System.Object,
ByVal e As System.EventArgs) Handles MyBase.Load

        End Sub
    Private Sub AddString()
        lstDelegates.Items.Add("Running AddString() method")
    End Sub
    Private Sub cmdDelegates_Click(ByVal sender As System.Object,
ByVal e As System.EventArgs) Handles cmdDelegates.Click
        Dim objDelegateAddString As DelegateAddString
        objDelegateAddString = AddressOf AddString
        objDelegateAddString.Invoke()
    End Sub
End Class
```

In the above there is a method called "AddString()" which adds a string to a listbox. You can also see a delegate declared as :-

Public Delegate Sub DelegateAddString()

This delegate signature is compatible with the "AddString" method. When I mean compatibility that means that there return types and passing parameter types are same.

Later in command click of the button object of the Delegate is created and the method pointer is received from “AddressOf” keyword. Then by using the “Invoke” method the method is invoked.

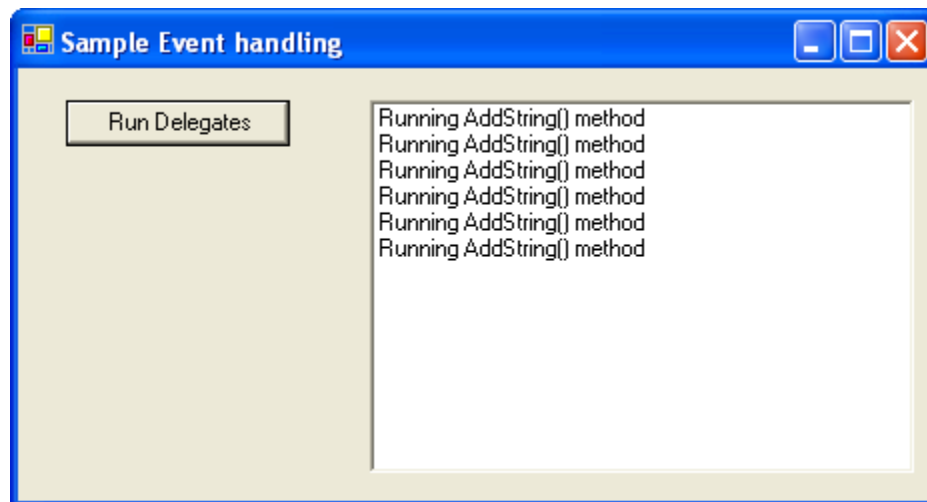

Figure :- 6.4 Delegate in Action

(B) What are events ?

As compared to delegates events works with source and listener methodology. So listeners who are interested in receiving some events they subscribe to the source. Once this subscription is done the source raises events to its entire listener when needed. One source can have multiple listeners.

In sample given below class “ClsWithEvents” is a event source class, which has a event “EventAddString()”. Now the listeners who are interested in receiving this events they can subscribe to this event. In class “FrmWithEvents” you can see they handle clause which is associated with the “mobjClsWithEvents” objects.

```
Public Class ClsWithEvents
    Event EventAddString(ByVal Value As String)
    Public Sub AddString()
        RaiseEvent EventAddString("String added by Event")
    End Sub
End Class
```

```
Public Class FrmWithEvents
    Inherits System.Windows.Forms.Form
    Private WithEvents mobjClsWithEvents As New ClsWithEvents()
    Private Sub FrmWithEvents_Load(ByVal sender As System.Object,
    ByVal e As System.EventArgs) Handles MyBase.Load

        End Sub

    Private Sub mobjClsWithEvents_EventAddString(ByVal Value As
    String) Handles mobjClsWithEvents.EventAddString
        LstData.Items.Add(Value)
    End Sub

    Private Sub CmdRunEvents_Click(ByVal sender As System.Object,
    ByVal e As System.EventArgs) Handles CmdRunEvents.Click
        mobjClsWithEvents.AddString()
    End Sub
End Class
```



Figure :- 6.5 Events in action

Nore:- Above source code is provided in "WindowsEvent"

(I) Do events have return type ?

No, events do not have return type.

(A) Can event's have access modifiers ?

Event's are always public as they are meant to serve every one register ing to it. But you can access modifiers in events.You can have events with protected keyword which will be accessible only to inherited classes.You can have private events only for object in that class.

(A) Can we have shared events ?

Yes, you can have shared event's note only shared methods can raise shared events.

(I) What is shadowing ?

When two elements in a program have same name, one of them can hide and shadow the other one. So in such cases the element which shadowed the main element is referenced.

Below is a sample code, there are two classes "ClsParent" and "ClsShadowedParent". In "ClsParent" there is a variable "x" which is a integer. "ClsShadowedParent" overrides "ClsParent" and shadows the "x" variable to a string.

Note:- In Sample CD "WindowsShadowing" is folder which has the sample code. If you run the program you can have two output's one which shows a integer and other which shows a string

```
Public Class ClsParent
    Public x As Integer
End Class
```

```
Public Class ClsShadowedParent
    Inherits ClsParent
    Public Shadows x As String
End Class
```

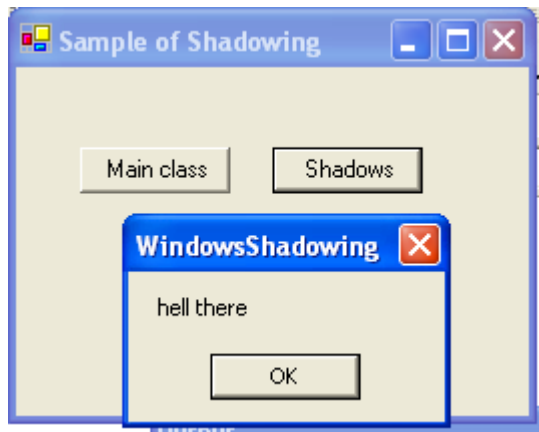

Figure :- 6.6 Shadowing in Action

(A) What is the difference between Shadowing and Overriding ?

Following are the differences between shadowing and overriding :-

- √ Overriding redefines only the implementation while shadowing redefines the whole element.
- √ In overriding derived classes can refer the parent class element by using "ME" keyword, but in shadowing you can access it by "MYBASE".

(I) What is the difference between delegate and events?

- √ Actually events use delegates in bottom. But they add an extra layer on the delegates, thus forming the publisher and subscriber model.
- √ As delegates are function to pointers they can move across any clients. So any of the clients can add or remove events, which can be pretty confusing. But events give the extra protection by adding the layer and making it a publisher and subscriber model.

Just imagine one of your clients doing this

c.XyzCallback = null

This will reset all your delegates to nothing and you have to keep searching where the error is.

(B) If we inherit a class do the private variables also get inherited ?

Yes, the variables are inherited but can not be accessed directly by the class interface.

(B) What are the different accessibility levels defined in .NET ?

Following are the five levels of access modifiers :-

- √ Private : Only members of class have access.
- √ Protected :-All members in current class and in derived classes can access the variables.
- √ Friend (internal in C#) :- Only members in current project have access to the elements.
- √ Protected friend (protected internal in C#) :- All members in current project and all members in derived class can access the variables.
- √ Public :- All members have access in all classes and projects.

(I) Can you prevent a class from overriding ?

If you define a class as “Sealed” in C# and “NotInheritable” in VB.NET you can not inherit the class any further.

(I) What is the use of “MustInherit” keyword in VB.NET ?

If you want to create a abstract class in VB.NET it's done by using “MustInherit” keyword.You can not create an object of a class which is marked as “MustInherit”. When you define “MustInherit” keyword for class you can only use the class by inheriting.

Note :- There was huge typo in my previous versions for the above two questions. I hope some one has not lost good opportunity because of the same. Thanks to all my readers for pointing it out.

(I) Do interface have accessibility modifier?

All elements in Interface should be public. So by default all interface elements are public by default.

(A) What are similarities between Class and structure ?

Following are the similarities between classes and structures :-

- √ Both can have constructors, methods, properties, fields, constants, enumerations, events, and event handlers.
- √ Structures and classes can implement interface.
- √ Both of them can have constructors with and without parameter.
- √ Both can have delegates and events.

(A) What is the difference between Class and structure's ?

Following are the key differences between them :-

- √ Structure are value types and classes are reference types. So structures use stack and classes use heap.
- √ Structures members can not be declared as protected, but class members can be. You can not do inheritance in structures.
- √ Structures do not require constructors while classes require.
- √ Objects created from classes are terminated using Garbage collector. Structures are not destroyed using GC.

(B) What does virtual keyword mean ?

They signify that method and property can be overridden.

(B) What are shared (VB.NET)/Static(C#) variables?

Static/Shared classes are used when a class provides functionality which is not specific to any instance. In short if you want an object to be shared between multiple instances you will use a static/Shared class.

Following are features of Static/Shared classes :-

- √ They can not be instantiated. By default a object is created on the first method call to that object.
- √ Static/Shared classes can not be inherited.
- √ Static/Shared classes can have only static members.
- √ Static/Shared classes can have only static constructor.

Note :- In CD there is a folder "WindowsShared" which has a sample code for shared variables. Below is a snippet. It has a "AddCount" function which increments a static "intCount" variable. In form there are two buttons which creates a new object and displays the count of the static variable. Even though the object is created and destroyed, the variable values does not change. It retains its old value.

```
Public Class ClsShared
    Shared intCount As Integer
    Public Function AddCount() As Integer
        intCount = intCount + 1
        Return intCount
    End Function
End Class
```

```
Public Class FrmSharedClasses
    Inherits System.Windows.Forms.Form
    Private Sub CmdInstancel_Click(ByVal sender As System.Object, ByVal
e As System.EventArgs) Handles CmdInstancel.Click
        Dim pObjClsShared As New ClsShared()
        MessageBox.Show("The count at this moment is" &
        pObjClsShared.AddCount.ToString())
    End Sub
```

```
Private Sub CmdInstance2_Click(ByVal sender As System.Object, ByVal
e As System.EventArgs) Handles CmdInstance2.Click
        Dim pObjClsShared As New ClsShared()
        MessageBox.Show("The count at this moment is" &
        pObjClsShared.AddCount.ToString())
```

End Sub
End Class

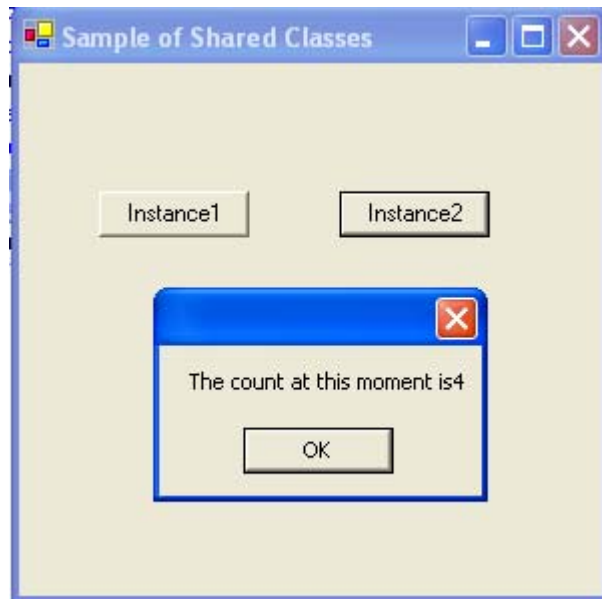

Figure :- 6.7 Shared/Static In Action

(B) What is Dispose method in .NET ?

.NET provides "Finalize" method in which we can clean up our resources. But relying on this is not always good so the best is to implement "IDisposable" interface and implement the "Dispose" method where you can put your clean up routines.

(B) What is the use of "OverRides" and "Overridable" keywords ?

Overridable is used in parent class to indicate that a method can be overridden. Overrides is used in the child class to indicate that you are overriding a method

(A) Where are all .NET Collection classes located ?

System.Collection namespace has all the collection classes available in .NET.

(A) What is ArrayList ?

Array is whose size can increase and decrease dynamically. Array list can hold item of different types. As Array list can increase and decrease size dynamically you do not have to use the REDIM keyword. You can access any item in array using the INDEX value of the array position.

(A) What's a HashTable ?

Twist :- What's difference between HashTable and ArrayList ?

You can access array using INDEX value of array, but how many times you know the real value of index. Hashtable provides way of accessing the index using a user identified KEY value, thus removing the INDEX problem.

(A) What are queues and stacks ?

Queue is for first-in, first-out (FIFO) structures. Stack is for last-in, first-out (LIFO) structures.

(B) What is ENUM ?

It's used to define constants.

(A) What is nested Classes ?

Nested classes are classes within classes. In sample below "ClsNested" class has a "ChildNested" class nested inside it.

```
Public Class ClsNested
    Public Class ChildNested
        Public Sub ShowMessage()
            MessageBox.Show("Hi this is nested class")
        End Sub
    End Class
End Class
```

This is the way we can instantiate the nested class and make the method call.

```
Dim pobjChildNested As New ClsNested.ChildNested()
pobjChildNested.ShowMessage()
```

Note:-In CD the above sample is provided in “WindowsNestedClasses”.

(B)What is Operator Overloading in .NET?

It provides a way to define and use operators such as +, -, and / for user-defined classes or structs. It allows us to define/redefine the way operators work with our classes and structs. This allows programmers to make their custom types look and feel like simple types such as int and string.

VB.NET till now does not support operator overloading. Operator overloading is done by using the “Operator” keyword.

Note:- Operator overloading is supported in VB.NET 2005

(I) In below sample code if we create a object of class2 which constructor will fire first ?

```
Public Class Class1  
Sub New()  
End Sub  
End Class  
Public Class class2  
Inherits Class1  
Sub New()  
End Sub  
End Class
```

* I leave this to the readers.....

(B)What is the significance of Finalize method in .NET?

.NET Garbage collector does almost all clean up activity for your objects. But unmanaged resources (ex: - Windows API created objects, File, Database connection objects, COM objects etc) is outside the scope of .NET framework we have to explicitly clean our resources. For these types of objects .NET framework provides Object.Finalize method

which can be overridden and clean up code for unmanaged resources can be put in this section.

(A)Why is it preferred to not use finalize for clean up?

Problem with finalize is that garbage collection has to make two rounds in order to remove objects which have finalize methods.

Below figure will make things clear regarding the two rounds of garbage collection rounds performed for the objects having finalized methods.

In this scenario there are three objects Object1, Object2 and Object3. Object2 has the finalize method overridden and remaining objects do not have the finalize method overridden.

Now when garbage collector runs for the first time it searches for objects whose memory has to free. He can see three objects but only cleans the memory for Object1 and Object3. Object2 it pushes to the finalization queue.

Now garbage collector runs for the second time. He see's there are no objects to be released and then checks for the finalization queue and at this moment it clears object2 from the memory.

So if you notice that object2 was released from memory in the second round and not first. That's why the best practice is not to write clean up Non.NET resources in Finalize method rather use the DISPOSE.

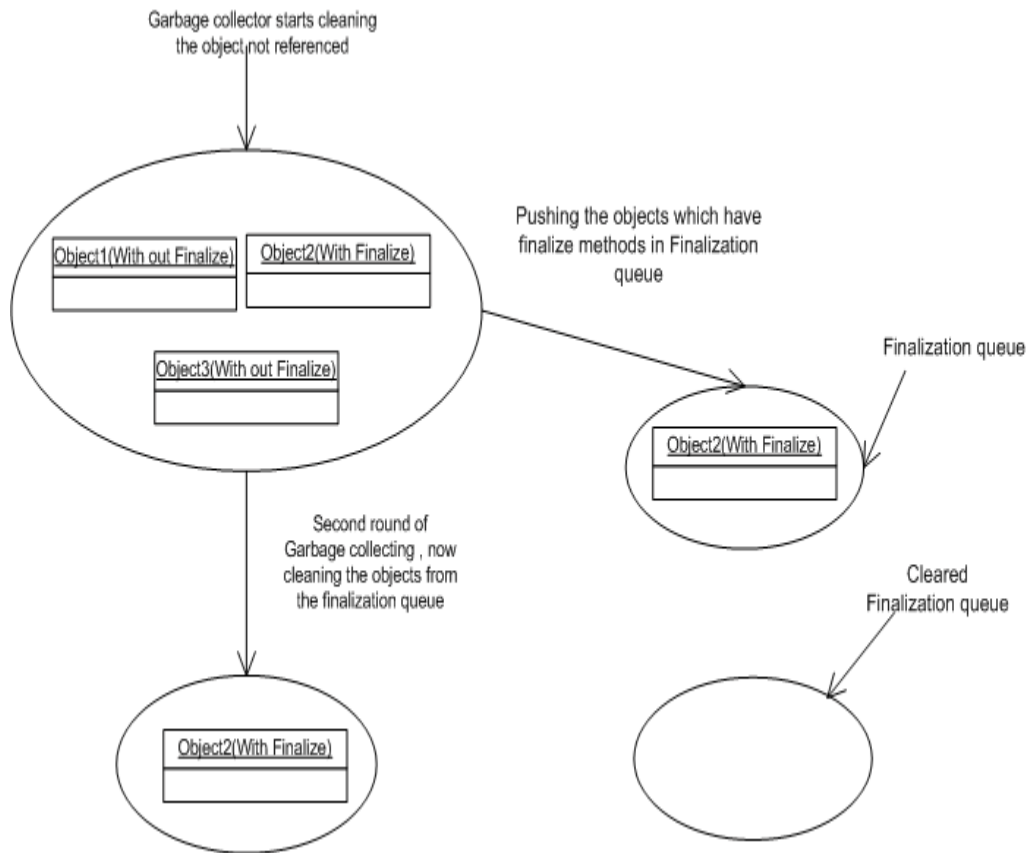

Figure :- 6.8 Garbage collection in actions

(I) How can we suppress a finalize method?

`GC.SuppressFinalize ()`

(B) What is the use of DISPOSE method?

Dispose method belongs to `IDisposable` interface. We had seen in the previous section how bad it can be to override the finalize method for writing the cleaning of unmanaged resources. So if any object wants to release its unmanaged code best is to implement

IDisposable and override the Dispose method of IDisposable interface. Now once your class has exposed the Dispose method it's the responsibility of the client to call the Dispose method to do the cleanup.

(A)How do I force the Dispose method to be called automatically, as clients can forget to call Dispose method?

Note :- I admire this question.

Call the Dispose method in Finalize method and in Dispose method suppress the finalize method using GC.SuppressFinalize. Below is the sample code of the pattern. This is the best way we do clean our unallocated resources and yes not to forget we do not get the hit of running the Garbage collector twice.

Note:- It will suppress the finalize method thus avoiding the two trip.

```
Public Class ClsTesting  
Implements IDisposable  
Public Overloads Sub Dispose()Implements IDisposable.Dispose  
' write ytour clean up code here  
GC.SuppressFinalize(Me)  
End Sub  
Protected Overrides Sub Finalize()  
Dispose()  
End Sub  
End Class
```

(I)In what instances you will declare a constructor to be private?

When we create a private constructor, we can not create object of the class directly from a client. So you will use private constructors when you do not want instances of the class to be created by any external client. Example UTILITY functions in project will have no

instance and be used without creating instance, as creating instances of the class would be waste of memory.

(I)Can we have different access modifiers on get/set methods of a property ?

No we can not have different modifiers same property. The access modifier on a property applies to both its get and set accessors.

(I)If we write a goto or a return statement in try and catch block will the finally block execute ?

The code in then finally always run even if there are statements like goto or a return statements.

(A)What is Indexer ?

An indexer is a member that enables an object to be indexed in the same way as an array.

(A)Can we have static indexer in C# ?

No.

(A)Can two catch blocks be executed?

No, once the proper catch section is executed the control goes finally to block. So there will not be any scenarios in which multiple catch blocks will be executed.

(A) What is the difference between System.String and System.StringBuilder classes?

System.String is immutable; System.StringBuilder can have mutable string where a variety of operations can be performed.

7 . ASP .NET

(B) What' is the sequence in which ASP.NET events are processed ?

Following is the sequence in which the events occur :-

- √ Page_Init.
- √ Page_Load.
- √ Control events
- √ Page_Unload event.

Page_init event only occurs when first time the page is started, but Page_Load occurs in subsequent request of the page.

(B) In which event are the controls fully loaded ?

Page_load event guarantees that all controls are fully loaded. Controls are also accessed in Page_Init events but you will see that viewstate is not fully loaded during this event.

(B) How can we identify that the Page isPostBack ?

Page object has a "IsPostBack" property which can be checked to know that is the page posted back.

(B) How does ASP.NET maintain state in between subsequent request ?

Refer caching chapter.

(A) What is event bubbling ?

Server controls like DataGrid, DataList, Repeater can have other child controls inside them. Example DataGrid can have combo box inside datagrid. These child control do not raise there events by themselves, rather they pass the event to the container parent (which can be a datagrid, datalist, repeater), which passed to the page as "ItemCommand" event. As the child control send there events to parent this is termed as event bubbling.

(B) How do we assign page specific attributes ?

Page attributes are specified using the @Page directive.

(A) If we want to make sure that no one has tampered with ViewState, how do we ensure it?

Using the @Page directive EnableViewStateMac to True.

(B) What is the use of @ Register directives ?

@Register directive informs the compiler of any custom server control added to the page.

(B) What's the use of SmartNavigation property ?

It's a feature provided by ASP.NET to prevent flickering and redrawing when the page is posted back.

Note:- This is only supported for IE browser. Project's who have browser compatibility as requirements have to think some other ways of avoiding flickering

(B) What is AppSetting Section in "Web.Config" file ?

Web.config file defines configuration for a webproject. Using "AppSetting" section we can define user defined values. Example below defined is "ConnectionString" section which will be used through out the project for database connection.

```
<configuration>  
<appSettings>  
<add key="ConnectionString" value="server=xyz;pwd=www;database=testing" />  
</appSettings>
```

(B) Where is ViewState information stored ?

In HTML Hidden Fields.

(I) What is the use of @ OutputCache directive in ASP.NET?

It is basically used for caching. See more for Caching chapter.

(B) How can we create custom controls in ASP.NET ?

User controls are created using .ASCX in ASP.NET. After .ASCX file is created you need to two things in order that the ASCX can be used in project:

√ Register the ASCX control in page using the <%@ Register directive. Example

```
<%@ Register tagprefix="Accounting" Tagname="footer" Src="Footer.ascx" %>
```

√ Now to use the above accounting footer in page you can use the below directive.

```
<Accounting:footer runat="server" />
```

(B) How many types of validation controls are provided by ASP.NET ?

There are six main types of validation controls :-

RequiredFieldValidator

It checks whether the control have any value. It's used when you want the control should not be empty.

RangeValidator

It checks if the value in validated control is in that specific range. Example TxtCustomerCode should not be more than eight length.

CompareValidator

It checks that the value in controls should match some specific value. Example Textbox TxtPie should be equal to 3.14.

RegularExpressionValidator

When we want the control value should match with a specific regular expression.

CustomValidator

It is used to define UserDefined validation.

ValidationSummary

It displays summary of all current validation errors.

Note:- It's rare that some one will ask step by step all the validation controls. Rather they will ask for what type of validation which validator will be used. Example in one of the interviews i was asked how you display summary of all errors in the validation control...just uttered one word Validation summary.

(B) Can you explain what is “AutoPostBack” feature in ASP.NET ?

If we want the control to automatically postback in case of any event, we will need to check this attribute as true. Example on a ComboBox change we need to send the event immediately to the server side then set the “AutoPostBack” attribute to true.

(B) How can you enable automatic paging in DataGrid ?

Following are the points to be done in order to enable paging in Datagrid :-

- √ Set the “AllowPaging” to true.
- √ In PageIndexChanged event set the current pageindex clicked.

Note:- The answers are very short, if you have implemented practically its just a revision. If you are fresher just make sample code using Datagrid and try to implement this functionality.

(B) What’s the use of “GLOBAL.ASAX” file ?

It allows to executing ASP.NET application level events and setting application-level variables.

(B) What is the difference between “Web.config” and “Machine.Config” ?

“Web.config” files apply settings to each web application, while “Machine.config” file apply settings to all ASP.NET applications.

(B) What is a SESSION and APPLICATION object ?

Session object store information between HTTP requests for a particular user, while application object are global across users.

(A) What is the difference between Server.Transfer and response.Redirect ?

Following are the major differences between them:-

- √ Response.Redirect sends message to the browser saying it to move to some different page, while server.transfer does not send any message to the browser but rather redirects the user directly from the server itself. So in server.transfer there is no round trip while response.redirect has a round trip and hence puts a load on server.
- √ Using Server.Transfer you can not redirect to a different from the server itself. Example if your server is www.yahoo.com you can use server.transfer to move to www.microsoft.com but yes you can move to www.yahoo.com/travels, i.e. within websites. This cross server redirect is possible only using Response.redirect.
- √ With server.transfer you can preserve your information. It has a parameter called as “preserveForm”. So the existing query string etc. will be able in the calling page.

If you are navigating within the same website use “Server.transfer” or else go for “response.redirect()”

(A)What is the difference between Authentication and authorization?

This can be a tricky question. These two concepts seem altogether similar but there is wide range of difference. Authentication is verifying the identity of a user and authorization is process where we check does this identity have access rights to the system. In short we can say the following authentication is the process of obtaining some sort of credentials

from the users and using those credentials to verify the user's identity. Authorization is the process of allowing an authenticated user access to resources. Authentication always proceed to Authorization; even if your application lets anonymous users connect and use the application, it still authenticates them as being anonymous.

(I) What is impersonation in ASP.NET ?

By default, ASP.NET executes in the security context of a restricted user account on the local machine. Sometimes you need to access network resources such as a file on a shared drive, which requires additional permissions. One way to overcome this restriction is to use impersonation. With impersonation, ASP.NET can execute the request using the identity of the client who is making the request, or ASP.NET can impersonate a specific account you specify in web.config.

(B) Can you explain in brief how the ASP.NET authentication process works?

ASP.NET does not run by itself, it runs inside the process of IIS. So there are two authentication layers which exist in ASP.NET system. First authentication happens at the IIS level and then at the ASP.NET level depending on the WEB.CONFIG file.

Below is how the whole process works:-

- √ IIS first checks to make sure the incoming request comes from an IP address that is allowed access to the domain. If not it denies the request.
- √ Next IIS performs its own user authentication if it is configured to do so. By default IIS allows anonymous access, so requests are automatically authenticated, but you can change this default on a per – application basis with in IIS.
- √ If the request is passed to ASP.net with an authenticated user, ASP.net checks to see whether impersonation is enabled. If impersonation is enabled, ASP.net acts as though it were the authenticated user. If not ASP.net acts with its own configured account.
- √ Finally the identity from step 3 is used to request resources from the operating system. If ASP.net authentication can obtain all the necessary resources it grants the users request otherwise it is denied. Resources can include much more than just the ASP.net page itself you can also use .Net's code access

security features to extend this authorization step to disk files, Registry keys and other resources.

(A) What are the various ways of authentication techniques in ASP.NET?

Selecting an authentication provider is as simple as making an entry in the web.config file for the application. You can use one of these entries to select the corresponding built in authentication provider:

- √ <authentication mode="windows">
- √ <authentication mode="passport">
- √ <authentication mode="forms">
- √ Custom authentication where you might install an ISAPI filter in IIS that compares incoming requests to list of source IP addresses, and considers requests to be authenticated if they come from an acceptable address. In that case, you would set the authentication mode to none to prevent any of the .net authentication providers from being triggered.

Windows authentication and IIS

If you select windows authentication for your ASP.NET application, you also have to configure authentication within IIS. This is because IIS provides Windows authentication. IIS gives you a choice for four different authentication methods:

Anonymous,basic,digest and windows integrated

If you select anonymous authentication, IIS doesn't perform any authentication, Any one is allowed to access the ASP.NET application.

If you select basic authentication, users must provide a windows username and password to connect. How ever this information is sent over the network in clear text, which makes basic authentication very much insecure over the internet.

If you select digest authentication, users must still provide a windows user name and password to connect. However the password is hashed before it is sent across the network. Digest authentication requires that all users be running Internet Explorer 5 or later and that windows accounts to stored in active directory.

If you select windows integrated authentication, passwords never cross the network. Users must still have a username and password, but the application uses either the Kerberos or challenge/response protocols to authenticate the user. Windows-integrated authentication requires that all users be running Internet Explorer 3.01 or later. Kerberos is a network authentication protocol. It is designed to provide strong authentication for client/server applications by using secret-key cryptography. Kerberos is a solution to network security problems. It provides the tools of authentication and strong cryptography over the network to help to secure information in systems across entire enterprise.

Passport authentication

Passport authentication lets you to use Microsoft's passport service to authenticate users of your application. If your users have signed up with passport, and you configure the authentication mode of the application to the passport authentication, all authentication duties are off-loaded to the passport servers.

Passport uses an encrypted cookie mechanism to indicate authenticated users. If users have already signed into passport when they visit your site, they'll be considered authenticated by ASP.NET. Otherwise they'll be redirected to the passport servers to log in. When they are successfully log in, they'll be redirected back to your site.

To use passport authentication you have to download the Passport Software Development Kit (SDK) and install it on your server. The SDK can be found at <http://msdn.microsoft.com/library/default.asp?url=/downloads/list/websrvpass.asp>. It includes full details of implementing passport authentication in your own applications.

Forms authentication

Forms authentication provides you with a way to handle authentication using your own custom logic within an ASP.NET application. The following applies if you choose forms authentication.

- √ When a user requests a page for the application, ASP.NET checks for the presence of a special session cookie. If the cookie is present, ASP.NET assumes the user is authenticated and processes the request.
- √ If the cookie isn't present, ASP.NET redirects the user to a web form you provide.

You can carry out whatever authentication, it check's you like it checks your form. When the user is authenticated, you indicate this to ASP.NET by setting a property, which creates the special cookie to handle subsequent requests.

(A)How does authorization work in ASP.NET?

ASP.NET impersonation is controlled by entries in the applications web.config file. The default setting is "no impersonation". You can explicitly specify that ASP.NET shouldn't use impersonation by including the following code in the file

```
<identity impersonate="false"/>
```

It means that ASP.NET will not perform any authentication and runs with its own privileges. By default ASP.NET runs as an unprivileged account named ASPNET. You can change this by making a setting in the processModel section of the machine.config file. When you make this setting, it automatically applies to every site on the server. To user a high-privileged system account instead of a low-privileged set the userName attribute of the processModel element to SYSTEM. Using this setting is a definite security risk, as it elevates the privileges of the ASP.NET process to a point where it can do bad things to the operating system.

When you disable impersonation, all the request will run in the context of the account running ASP.NET: either the ASPNET account or the system account. This is true when you are using anonymous access or authenticating users in some fashion. After the user has been authenticated, ASP.NET uses its own identity to request access to resources.

The second possible setting is to turn on impersonation.

```
<identity impersonate ="true"/>
```

In this case, ASP.NET takes on the identity IIS passes to it. If you are allowing anonymous access in IIS, this means ASP.NET will impersonate the IUSR_ComputerName account that IIS itself uses. If you aren't allowing anonymous access,ASP.NET will take on the credentials of the authenticated user and make requests for resources as if it were that user. Thus by turning impersonation on and using a non-anonymous method of authentication in IIS, you can let users log on and use their identities within your ASP.NET application.

Finally, you can specify a particular identity to use for all authenticated requests

```
<identity impersonate="true" username="DOMAIN\username" password="password"/>
```

With this setting, all the requests are made as the specified user (Assuming the password is correct in the configuration file). So, for example you could designate a user for a single application, and use that user's identity every time someone authenticates to the application. The drawback to this technique is that you must embed the user's password in the web.config file in plain text. Although ASP.NET won't allow anyone to download this file, this is still a security risk if anyone can get the file by other means.

(B)What's difference between Datagrid, Datalist and repeater ?

A Datagrid, Datalist and Repeater are all ASP.NET data Web controls.

They have many things in common like DataSource Property, DataBind Method ItemDataBound and ItemCreated.

When you assign the DataSource Property of a Datagrid to a DataSet then each DataRow present in the DataRow Collection of DataTable is assigned to a corresponding DataGridItem and this is same for the rest of the two controls also. But The HTML code generated for a Datagrid has an HTML TABLE <ROW> element created for the particular DataRow and its a Table form representation with Columns and Rows.

For a Datalist its an Array of Rows and based on the Template Selected and the RepeatColumn Property value We can specify how many DataSource records should appear per HTML <table> row. In short in datagrid we have one record per row, but in datalist we can have five or six rows per row.

For a Repeater Control, the Datarecords to be displayed depends upon the Templates specified and the only HTML generated is the due to the Templates.

In addition to these, Datagrid has a in-built support for Sort, Filter and paging the Data, which is not possible when using a DataList and for a Repeater Control we would require to write an explicit code to do paging.

(A)From performance point of view how do they rate ?

Repeater is fastest followed by Datalist and finally datagrid.

(B)What is the method to customize columns in DataGrid?

Use the template column.

(B)How can we format data inside DataGrid?

Use the DataFormatString property.

(A) How to decide on the design consideration to take a Datagrid, datalist or repeater ?

Many make a blind choice of choosing datagrid directly, but that's not the right way.

Datagrid provides ability to allow the end-user to sort, page, and edit its data. But it comes at a cost of speed. Second the display format is simple that is in row and columns. Real life scenarios can be more demanding that

With its templates, the DataList provides more control over the look and feel of the displayed data than the DataGrid. It offers better performance than datagrid

Repeater control allows for complete and total control. With the Repeater, the only HTML emitted are the values of the databinding statements in the templates along with the HTML markup specified in the templates—no "extra" HTML is emitted, as with the DataGrid and DataList. By requiring the developer to specify the complete generated HTML markup, the Repeater often requires the longest development time. But repeater does not provide editing features like datagrid so everything has to be coded by programmer. However, the Repeater does boast the best performance of the three data Web controls. Repeater is fastest followed by Datalist and finally datagrid.

(B) Difference between ASP and ASP.NET?

ASP.NET new feature supports are as follows :-

Better Language Support

- √ New ADO.NET Concepts have been implemented.
- √ ASP.NET supports full language (C#, VB.NET, C++) and not simple scripting like VBSCRIPT..

Better controls than ASP

- √ ASP.NET covers large set's of HTML controls..
- √ Better Display grid like Datagrid, Repeater and datalist.Many of the display grids have paging support.

Controls have events support

- √ All ASP.NET controls support events.
- √ Load, Click and Change events handled by code makes coding much simpler and much better organized.

Compiled Code

The first request for an ASP.NET page on the server will compile the ASP.NET code and keep a cached copy in memory. The result of this is greatly increased performance.

Better Authentication Support

ASP.NET supports forms-based user authentication, including cookie management and automatic redirecting of unauthorized logins. (You can still do your custom login page and custom user checking).

User Accounts and Roles

ASP.NET allows for user accounts and roles, to give each user (with a given role) access to different server code and executables.

High Scalability

- √ Much has been done with ASP.NET to provide greater scalability.
- √ Server to server communication has been greatly enhanced, making it possible to scale an application over several servers. One example of this is the ability to run XML parsers, XSL transformations and even resource hungry session objects on other servers.

Easy Configuration

- √ Configuration of ASP.NET is done with plain text files.
- √ Configuration files can be uploaded or changed while the application is running. No need to restart the server. No more metabase or registry puzzle.

Easy Deployment

No more server restart to deploy or replace compiled code. ASP.NET simply redirects all new requests to the new code.

(A) What are major events in GLOBAL.ASAX file ?

The Global.asax file, which is derived from the `HttpApplication` class, maintains a pool of `HttpApplication` objects, and assigns them to applications as needed. The Global.asax file contains the following events:

Application_Init: Fired when an application initializes or is first called. It is invoked for all `HttpApplication` object instances.

Application_Disposed: Fired just before an application is destroyed. This is the ideal location for cleaning up previously used resources.

Application_Error: Fired when an unhandled exception is encountered within the application.

Application_Start: Fired when the first instance of the `HttpApplication` class is created. It allows you to create objects that are accessible by all `HttpApplication` instances.

Application_End: Fired when the last instance of an `HttpApplication` class is destroyed. It is fired only once during an application's lifetime.

Application_BeginRequest: Fired when an application request is received. It is the first event fired for a request, which is often a page request (URL) that a user enters.

Application_EndRequest: The last event fired for an application request.

Application_PreRequestHandlerExecute: Fired before the ASP.NET page framework begins executing an event handler like a page or Web service.

Application_PostRequestHandlerExecute: Fired when the ASP.NET page framework has finished executing an event handler.

Application_PreSendRequestHeaders: Fired before the ASP.NET page framework sends HTTP headers to a requesting client (browser).

Application_PreSendContent: Fired before the ASP.NET page framework send content to a requesting client (browser).

Application_AcquireRequestState: Fired when the ASP.NET page framework gets the current state (Session state) related to the current request.

Application_ReleaseRequestState: Fired when the ASP.NET page framework completes execution of all event handlers. This results in all state modules to save their current state data.

Application_ResolveRequestCache: Fired when the ASP.NET page framework completes an authorization request. It allows caching modules to serve the request from the cache, thus bypassing handler execution.

Application_UpdateRequestCache: Fired when the ASP.NET page framework completes handler execution to allow caching modules to store responses to be used to handle subsequent requests.

Application_AuthenticateRequest: Fired when the security module has established the current user's identity as valid. At this point, the user's credentials have been validated.

Application_AuthorizeRequest: Fired when the security module has verified that a user can access resources.

Session_Start: Fired when a new user visits the application Web site.

Session_End: Fired when a user's session times out, ends, or they leave the application Web site.

Note :- During interview you do not have to really cram all these events. But just keep the basic events in mind

(A) What order they are triggered ?

They're triggered in the following order:

Application_BeginRequest

Application_AuthenticateRequest

Application_AuthorizeRequest

Application_ResolveRequestCache

Application_AcquireRequestState

Application_PreRequestHandlerExecute

Application_PreSendRequestHeaders

Application_PreSendRequestContent

<<code is executed>>

Application_PostRequestHandlerExecute

Application_ReleaseRequestState

Application_UpdateRequestCache

Application_EndRequest.

(I) Do session use cookies ?

Twist:- How can we make session to not to use cookies ?

Left to the user, you will enjoy to find this answer.

(I)How can we force all the validation control to run ?

Page.Validate

(B)How can we check if all the validation control are valid and proper ?

Using the Page.IsValid() property you can check whether all the validation are done.

(A)If client side validation is enabled in your Web page, does that mean server side code is not run?

When client side validation is enabled server emit's JavaScript code for the custom validators. But note that does not mean that server side checks on custom validators do not execute. It does this redundant check two times as some of the validators do not support client side scripting.

(A)Which JavaScript file is referenced for validating the validators at the client side ?

WebUIValidation.js javascript file installed at “aspnet_client” root IIS directory is used to validate the validation controls at the client side

(B)How to disable client side script in validators?

Set EnableClientScript to false.

(A)How can I show the entire validation error message in a message box on the client side?

In validation summary set “ShowMessageBox” to true.

(B)You find that one of your validation is very complicated and does not fit in any of the validators, what will you do ?

Best is to go for CustomValidators. Below is a sample code for a custom validator which checks that a textbox should not have zero value

```
<asp:CustomValidator id="CustomValidator1" runat="server"
    ErrorMessage="Number not divisible by Zero"
    ControlToValidate="txtNumber"
    OnServerValidate="ServerValidate"
    ClientValidationFunction="CheckZero" /><br>
```

Input:

```
<asp:TextBox id="txtNumber" runat="server" />
<script language="javascript">
<!--
function CheckZero(source, args) {
    int val = parseInt(args.Value, 10);
    if (value==0) {
        args.IsValid = false;
    }
}
```

```
else {  
    args.IsValid = true;  
}  
}  
// -->  
</script>
```

(A)What is Tracing in ASP.NET ?

Tracing allows us to view how the code was executed in detail.

(A) How do we enable tracing ?

```
<%@ Page Trace="true" %>
```

(I)What exactly happens when ASPX page is requested from Browser?

Note: - Here the interviewer is expecting complete flow of how an ASPX page is processed with respect to IIS and ASP.NET engine.

Following are the steps which occur when we request a ASPX page :-

- √ The browser sends the request to the webserver. Let us assume that the webserver at the other end is IIS.
- √ Once IIS receives the request he looks on which engine can serve this request. When I mean engine means the DLL who can parse this page or compile and send a response back to browser. Which request to map to is decided by file extension of the page requested.

Depending on file extension following are some mapping

- √ .aspx, for ASP.NET Web pages,
- √ .asmx, for ASP.NET Web services,
- √ .config, for ASP.NET configuration files,
- √ .ashx, for custom ASP.NET HTTP handlers,

-
- √ .rem, for remoting resources
 - √ Etc

You can also configure the extension mapping to which engine can route by using the IIS engine.

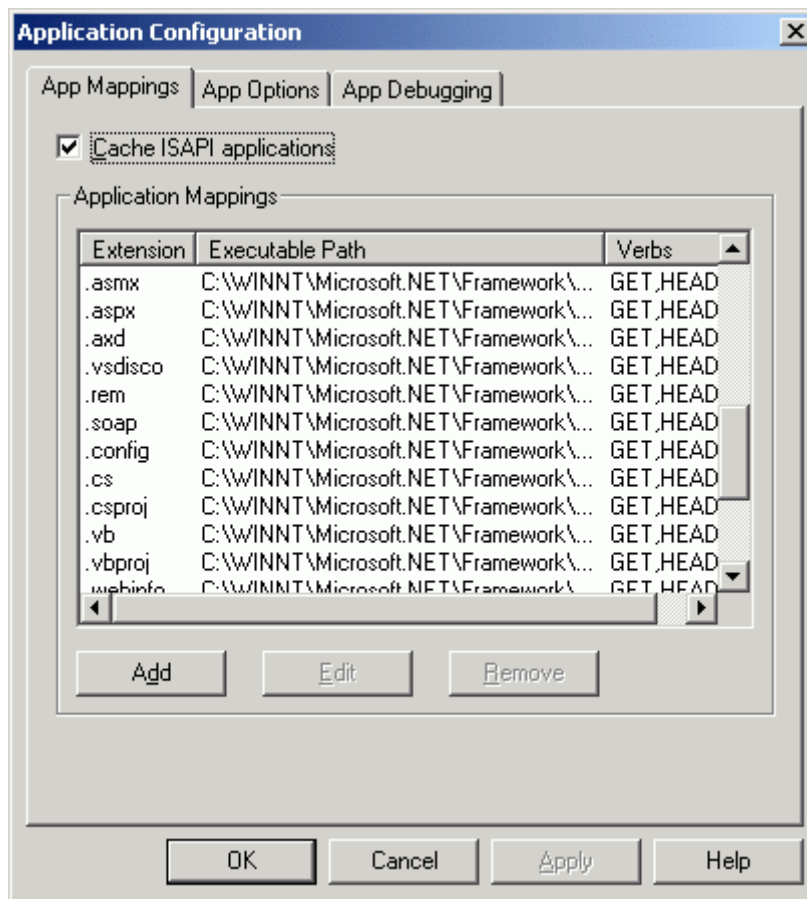

Figure: - 7.1 Following screen shows some IIS mappings

Example an ASP page will be sent to old classic ASP.DLL to compile. While .ASPX pages will be routed to ASP.NET engine for compilation.

-
- √ As this book mainly will target ASP.NET we will look in to how ASP.NET pages that is ASPX pages generation sequence occurs. Once IIS passes the request to ASP.NET engine page has to go through two section HTTP module section and HTTP handler section. Both these section have there own work to be done in order that the page is properly compiled and sent to the IIS. HTTP modules inspect the incoming request and depending on that they can change the internal workflow of the request. HTTP handler actually compiles the page and generates output. If you see your machine.config file you will see following section of HTTP modules

```
<httpModules>
  <add name="OutputCache" type="System.Web.Caching.OutputCacheModule" />
  <add name="Session" type="System.Web.SessionState.SessionStateModule" />
  <add name="WindowsAuthentication"
type="System.Web.Security.WindowsAuthenticationModule" />
  <add name="FormsAuthentication"
type="System.Web.Security.FormsAuthenticationModule" />
  <add name="PassportAuthentication"
type="System.Web.Security.PassportAuthenticationModule" />
  <add name="UrlAuthorization"
type="System.Web.Security.UrlAuthorizationModule" />
  <add name="FileAuthorization"
type="System.Web.Security.FileAuthorizationModule" />
  <add name="ErrorHandlerModule" type="System.Web.Mobile.ErrorHandlerModule,
System.Web.Mobile, Version=1.0.5000.0,
Culture=neutral, PublicKeyToken=b03f5f7f11d50a3a" /
>
</httpModules>
```

The above mapping will show which functionality is handled by which Namespace. Example FormsAthentication is handled by "System.Web.

Security.FormsAuthenticationModule". If you look at the web.config section HTTP module is where authentication and authorization happens.

Ok now the HTTP handler is where the actual compilation takes place and the output is generated. Following is a paste from HTTP handler section of WEB.CONFIG file.

```
<httpHandlers>
  <add verb="*" path="*.vjsproj" type="System.Web.HttpForbiddenHandler" />
  <add verb="*" path="*.java" type="System.Web.HttpForbiddenHandler" />
  <add verb="*" path="*.jsl" type="System.Web.HttpForbiddenHandler" />
  <add verb="*" path="trace.axd" type="System.Web.Handlers.TraceHandler" />
  <add verb="*" path="*.aspx" type="System.Web.UI.PageHandlerFactory" />
  <add verb="*" path="*.ashx" type="System.Web.UI.SimpleHandlerFactory" />
  ...
</httpHandlers>
```

- √ Depending on the File extension handler decides which Namespace will generate the output. Example all .ASPX extension files will be compiled by System.Web.UI.PageHandlerFactory

- √ Once the file is compiled it will be send back again to the HTTP modules and from there to IIS and then to the browser.

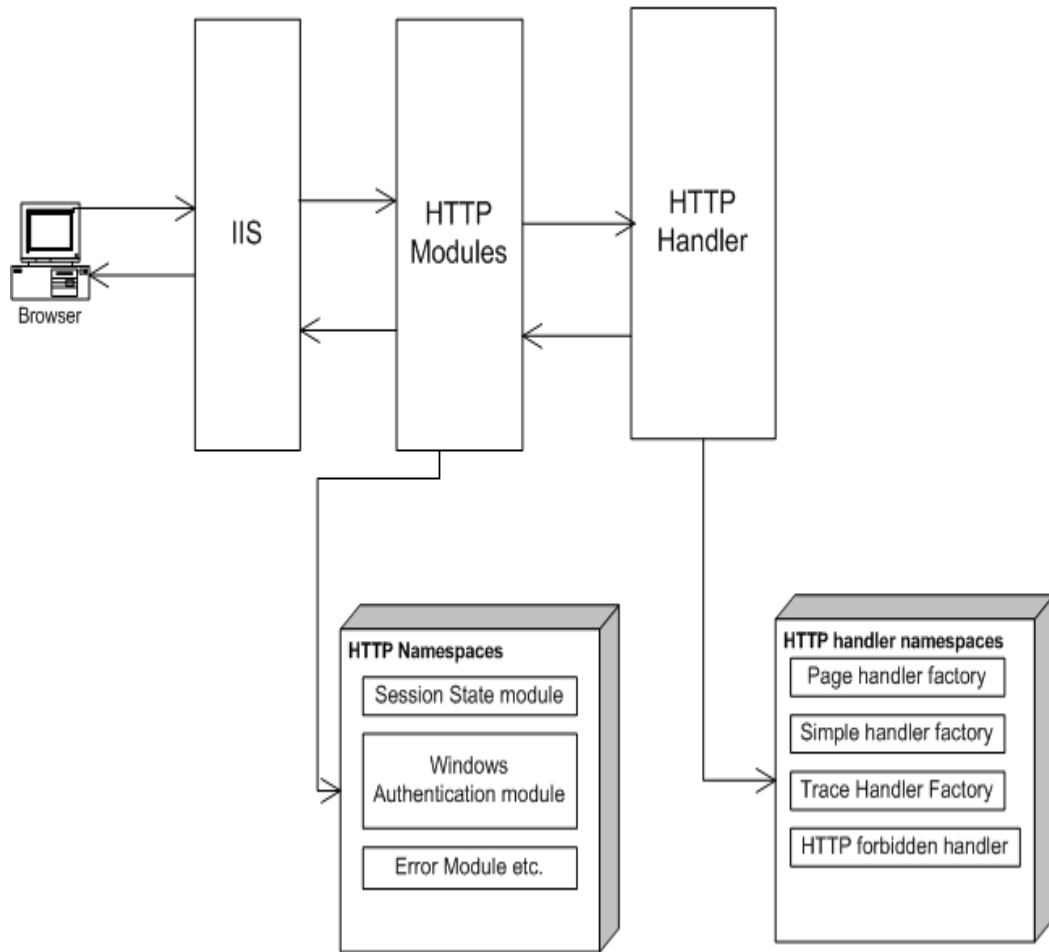

Figure :- 7.2 IIS flow from various sections.

(B)How can we kill a user session ?

Session.abandon

(I)How do you upload a file in ASP.NET ?

I will leave this to the readers ... Just a hint we have to use System.Web.HttpPostedFile class.

(I)How do I send email message from ASP.NET ?

ASP.NET provides two namespaces System.WEB.mailmessage class and System.Web.Mail.Smtpmail class. Just a small homework create a Asp.NET project and send a email at shiv_koirala@yahoo.com. Do not Spam.

(A)What are different IIS isolation levels?

IIS has three level of isolation:-

LOW (IIS process):- In this main IIS process and ASP.NET application run in same process. So if any one crashes the other is also affected. Example let's say (well this is not possible) I have hosted yahoo, hotmail .amazon and google on a single PC. So all application and the IIS process runs on the same process. In case any website crashes it affects every one.



Figure: - 7.3 LOW IIS process scenario

Medium (Pooled):- In Medium pooled scenario the IIS and web application run in different process. So in this case there are two processes process1 and process2. In process1 the IIS process is running and in process2 we have all Web application running.

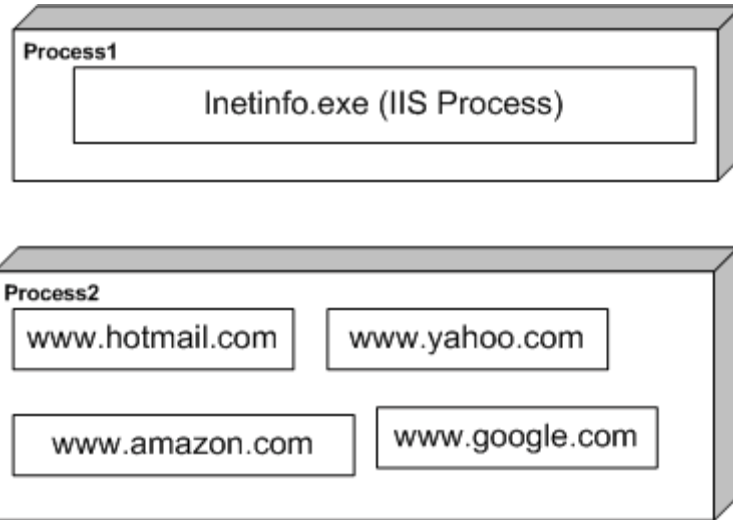

Figure: - 7.4 Medium pooled scenario

High (Isolated):-In high isolated scenario every process is running is there own process. In below figure there are five processes and every one handling individual application. This consumes heavy memory but has highest reliability.

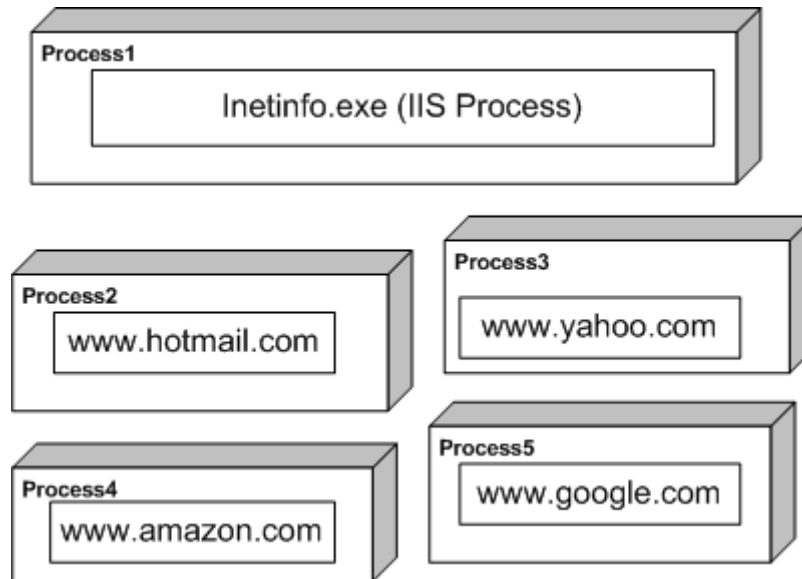

Figure: - 7.5 High isolation scenario

(A)ASP used STA threading model, what is the threading model used for ASP.NET ?

ASP.NET uses MTA threading model.

(A)What is the use of `<%@ page aspcompat=true %>` attribute ?

This attribute works like a compatibility option. As mentioned before ASP worked in STA model and ASP.NET works in MTA model, but what if your ASP.NET application is using a VB COM component. In order that VB COM runs properly in ASP.NET threading model we have to set attribute. After defining the ASPCOMPAT directive attribute ASP.NET pages runs in STA model thus building the compatibility between ASP.NET and old COM components that does not support MTA model.

(B) Explain the differences between Server-side and Client-side code?

Server side code is executed at the server side on IIS in ASP.NET framework, while client side code is executed on the browser.

(I) Can you explain Forms authentication in detail ?

In old ASP if you were said to create a login page and do authentication you have to do hell lot of custom coding. But now in ASP.NET that's made easy by introducing Forms authentication. So let's see in detail what form authentication is.

Forms authentication uses a ticket cookie to see that user is authenticated or not. That means when user is authenticated first time a cookie is set to tell that this user is authenticated. If the cookies expire then Forms authentication mechanism sends the user to the login page.

Following are the steps which defines steps for Forms authentication :-

- √ Configure Web.config file with forms authentication. As shown below in the config file you can see we have give the cookie name and loginurl page.

```
<configuration>
  <system.web>
    <!-- Other settings omitted. -->
    <authentication mode="Forms">
      <forms name="logincookies"
        loginUrl="login.aspx"
        protection="All"
        timeout="30"
        path="/" />
    </authentication>
  </system.web>
</configuration>
```

-
- √ Remove anonymous access to the IIS web application, following are changes done to web.config file.

```
<configuration>  
  <system.web>  
    <!-- Other settings omitted. -->  
    <authorization>  
      <deny users="?" />  
    </authorization>  
  </system.web>  
</configuration>
```

- √ Create the login page which will accept user information. You will have create your login page that is the Login.aspx which will actually take the user data.

- √ Finally a Small coding in the login button.

Let us assume that the login page has two textboxes Txtname and txtapssword.

Also import System.Web.Security and put the following code in login button of the page.

If Page.IsValid Then

If FormsAuthentication.Authenticate(txtName.Text, txtPassword.Text) Then

FormsAuthentication.RedirectFromLoginPage(txtName.Text, False)

Else

lblStatus.Text = "Error not proper user"

End If

End If

(A)How do I sign out in forms authentication ?

FormsAuthentication.Signout()

(A)If cookies are not enabled at browser end does form Authentication work?

No, it does not work.

(A)How to use a checkbox in a datagrid?

Twist :- How can I track event in checkbox which is one of the columns of a datagrid ?

Note: - This is normally asked when the interviewer want to see that have you really worked practically on a project.

Following are the steps to be done :-

- √ In ASPX page you have to add Itemtemplate tag in datagrid.

<ItemTemplate>

<asp:CheckBox id="CheckBox1" runat="server" AutoPostBack="True" OnCheckedChanged="Check_Clicked"></asp:CheckBox>

</ItemTemplate>

- √ If you look at the Itemtemplate we have “OnCheckChanged” event. This “OnCheckChanged” event has “Check_Clicked” subroutine is actually in behind code. Note this method which is in behind code should either be “protected” or “public”

- √ Following below is the subroutine which defines the method

Protected Sub Check_Clicked(ByVal sender As Object, ByVal e As EventArgs)

‘ do something

End Sub

The above steps should be defined in short to the interviewer which will give a quick feeling of your practical experience with ASP.NET

(I)What are the steps to create a windows service in VB.NET ?

Windows Services are long-running executable applications that run in its own Windows session, which then has the ability to start automatically when the computer boots and also can be manually paused, stopped or even restarted.

Following are the steps to create a service :-

- √ Create a project of type “Windows Service”.

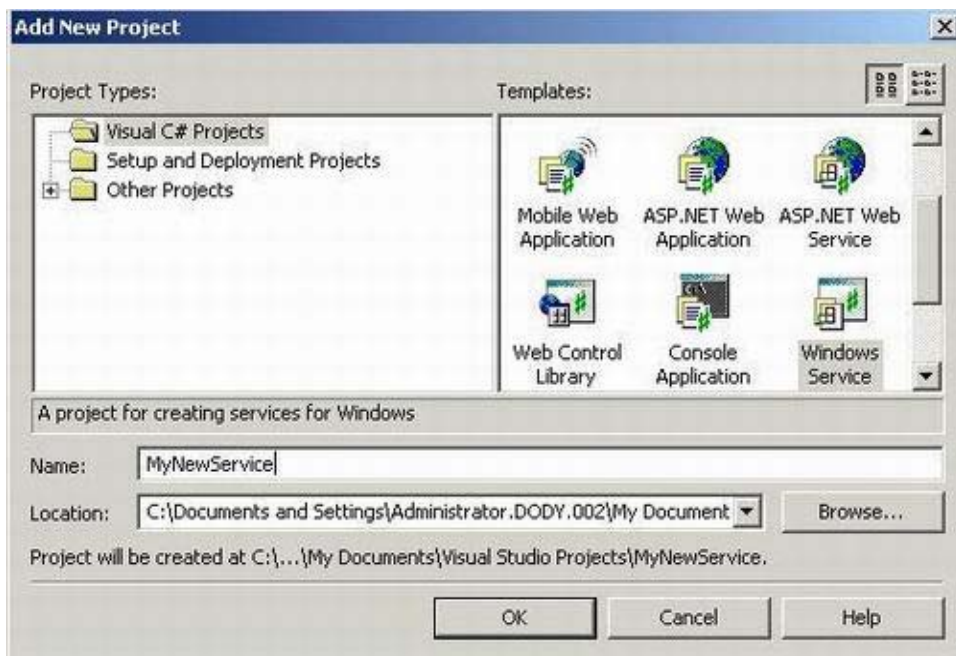

Figure 7.6 :- Create project for Windows Service

- √ If you see the class created it is automatically inheriting from “System.ServiceProcess.ServiceBase”.

-
- √ You can override the following events provided by service and write your custom code. All the three main events can be used that is Start, stop and continue.

```
protected override void OnStart(string[] args)
```

```
{
```

```
}
```

```
protected override void OnStop()
```

```
{
```

```
}
```

```
protected override void OnContinue()
```

```
{
```

```
}
```

- √ Now to install the service you need to do run the install util exe.

```
InstallUtil <Project Path>\BIN\MyNewService.exe
```

(A) What is the difference between “Web farms” and “Web garden”?

“Web farms” are used to have some redundancy to minimize failures. It consists of two or more web server of the same configuration and they stream the same kind of contents. When any request comes there is switching / routing logic which decides which web server from the farm handles the request. For instance we have two servers “Server1” and “Server2” which have the same configuration and content. So there is a special switch which stands in between these two servers and the users and routes the request accordingly.

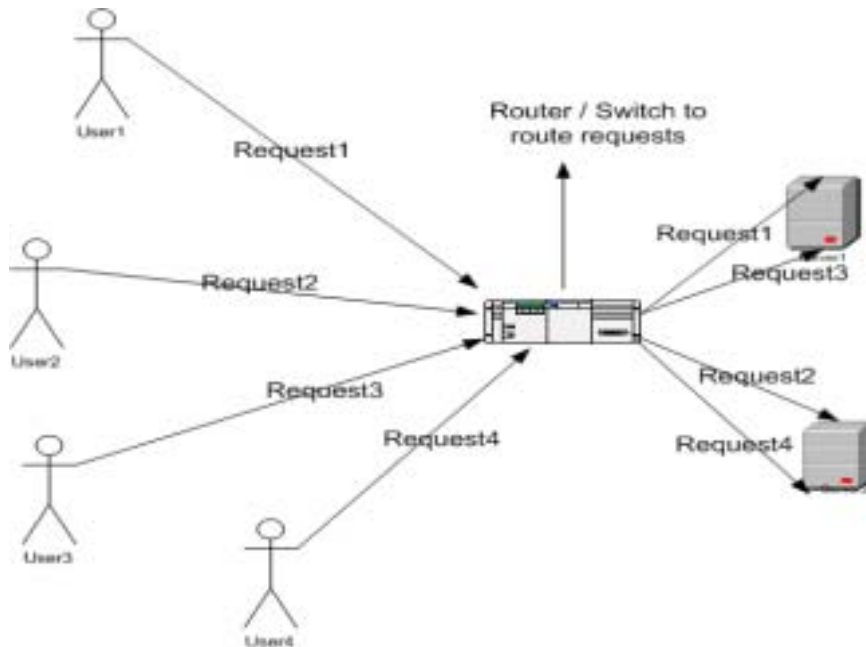

Figure 7.7 : - Web Farm in action

Above figure explains in detail how web farm work. You can see there is a router in between which takes a request and sees which one of the server is least loaded and forwards the request to that server. So for request1 it route's server1, for request2 it routes server2, for request3 it routes to server3 and final request4 is routed to server4. So you can see because we have web farm at place server1 and server2 are loaded with two request each rather than one server loading to full. One more advantage of using this kind of architecture is if one of the servers goes down we can still run with the other server thus having 24x7 uptime.

The routing logic can be a number of different options:-

- √ Round-robin: Each node gets a request sent to it "in turn". So, server1 gets a request, then server2 again, then server1, then server2 again. As shown in the above figure.

-
- √ Least Active: Whichever node show to have the lowest number of current connects gets new connects sent to it. This is good to help keep the load balanced between the server nodes.
 - √ Fastest Reply: Whichever node replies faster is the one that gets new requests. This is also a good option - especially if there are nodes that might not be “equal” in performance. If one performs better than the other, then send more requests there rather than which is moving slowly?

Before we try to understand what a web garden is let’s try to understand how IIS handles processes. All requests to IIS are routed to “aspnet_wp.exe” for IIS 5.0 and “w3wp.exe” for IIS 6.0. In normal case i.e. with out web garden we have one worker process instance (“aspnet_wp.exe” / “w3wp.exe”) across all requests. This one instance of worker process uses the CPU processor as directed by the operating system.

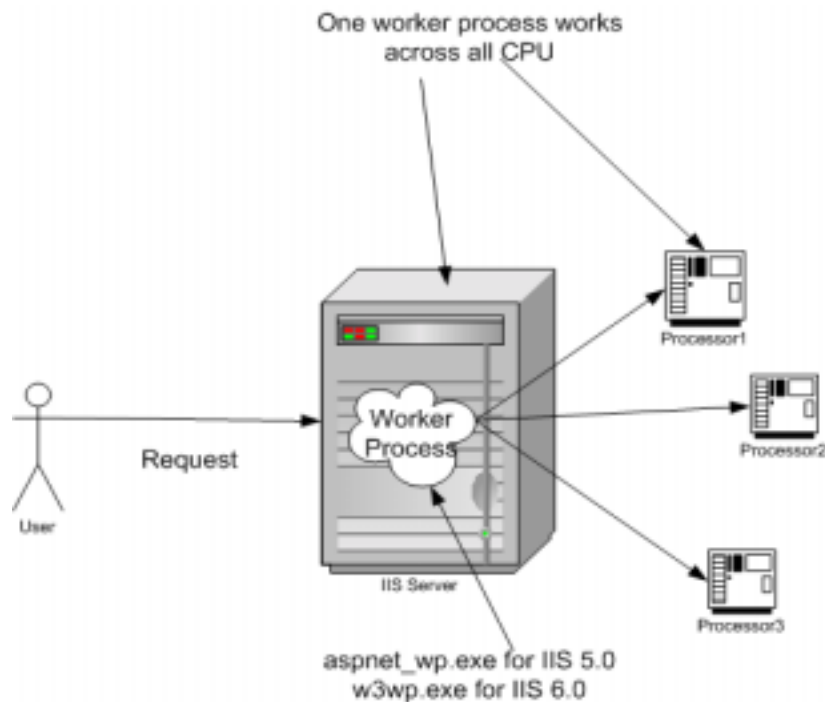

Figure 7.8 : - With out Web Garden

But when we enable web garden for a web server it creates different instances of the worker process and each of these worker process runs on different CPU. You can see in the below diagram we have different worker process instances created which run on different CPU's.

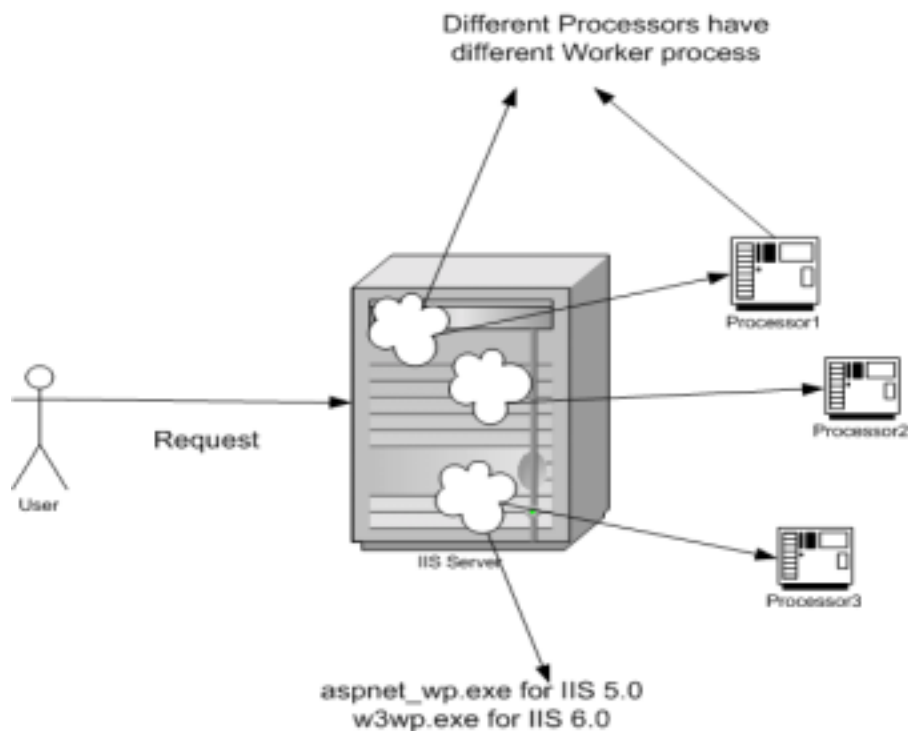

Figure 7.9 : - With Web Garden

In short we can define a model in which multiple processes run on multiple CPUs in a single server machine are known as a Web garden.

(A) How do we configure “WebGarden”?

“Web garden” can be configured by using process model settings in “machine.config” or “Web.config” file. The configuration section is named <processModel> and is shown in

the following example. The process model is enabled by default (enable="true"). Below is the snippet from config file.

```
<processModel
  enable="true"
  timeout="infinite"
  idleTimeout="infinite"
  shutdownTimeout="0:00:05"
  requestLimit="infinite"
  requestQueueLimit="5000"
  memoryLimit="80"
  webGarden="false"
  cpuMask="12"
  userName=""
  password=""
  logLevel="errors"
  clientConnectedCheck="0:00:05"
/>
```

From the above processmodel section for web garden we are concerned with only two attributes "webgarden" and "cpuMask".

webGarden :- Controls CPU affinity. True indicates that processes should be affinitized to the corresponding CPU. The default is False.

cpuMask:- Specifies which processors on a multiprocessor server are eligible to run ASP.NET processes. The cpuMask value specifies a bit pattern that indicates the CPUs eligible to run ASP.NET threads. ASP.NET launches one worker process for each eligible CPU. If webGarden is set to false, cpuMask is ignored and only one worker process will run regardless of the number of processors in the machine. If webGarden is set to true, ASP.NET launches one worker process for each CPU that corresponds to a set bit in cpuMask. The default value of cpuMask is 0xffffffff.

Below are detail steps of how to implement web garden

- √ click Start and then click Run.
- √ type calc.exe and then click OK.
- √ Goto View menu, click Scientific.
- √ Goto View menu, click Binary.
- √ Use 0 and 1 to specify the processors ASP.NET can or cannot use.

Use 1 for the processor that you want to use for ASP.NET. Use 0 for the processor that you do not want to use for ASP.NET. For example, if you want to use the first two processors for ASP.NET of a four-processor computer, type 1100.

- √ On the View menu, click Decimal. Note the decimal number.
- √ Open the Web.config or machine.config file in a text editor such as Notepad. The Web.config file is located in the folder where the application is saved.
- √ In the Web.config file, add the processModel configuration element under the System.web element. Before adding <processModel> to Web.config file, the user has to make sure that the allowDefinition attribute in the <processModel> section of the Web.config file is set to everywhere.
- √ Add and then set the webGarden attribute of the processModel element to True.
- √ Add and then set the cpuMask attribute of the processModel element to the result that is determined in your calculation.

Do not preface the number with 0x because the result of the calculation is a decimal number. The following example demonstrates the processModel element that is configured to enable only the first two processors of a four-processor computer.

```
<processModel  
  enable="true"  
  webGarden="true"  
  cpuMask="12" />
```

Save the Web.config file. The ASP.NET application automatically restarts and uses only the specified processors.

(B)What is the main difference between GridLayout and FlowLayout ?

GridLayout provides absolute positioning for controls placed on the page. Developers that have their roots in rich-client development environments like Visual Basic will find it easier to develop their pages using absolute positioning, because they can place items exactly where they want them. On the other hand, FlowLayout positions items down the page like traditional HTML. Experienced Web developers favor this approach because it results in pages that are compatible with a wider range of browsers.

If you look in to the HTML code created by absolute positioning you can notice lot of DIV tags. While in Flow layout you can see more of using HTML table to position elements which is compatible with wide range of browsers.

8..NET Architecture

(B) What are design patterns ?

Design patterns are recurring solution to recurring problems in software architecture.

(A) Can you list down all patterns and their classification ?

Note :- This is advanced question because anyone who asks to list down all patterns can only be crazy for what he is asking. But it is always a win-win situation for the interviewer.

There are three basic classification of patterns Creational, Structural and Behavioral patterns.

Creational Patterns

- √ Abstract Factory:- Creates an instance of several families of classes
- √ Builder :- Separates object construction from its representation
- √ Factory Method:- Creates an instance of several derived classes
- √ Prototype:- A fully initialized instance to be copied or cloned
- √ Singleton:- A class in which only a single instance can exist

Note :- The best way to remember Creational pattern is by ABFPS (Abraham Became First President of States).

Structural Patterns

- √ Adapter:-Match interfaces of different classes.
- √ Bridge:-Separates an object's interface from its implementation.
- √ Composite:-A tree structure of simple and composite objects.
- √ Decorator :-Add responsibilities to objects dynamically.
- √ Façade:-A single class that represents an entire subsystem.
- √ Flyweight:-A fine-grained instance used for efficient sharing.
- √ Proxy:-An object representing another object.

Note : To remember structural pattern best is (ABCDFFP)

Behavioral Patterns

- √ Mediator:-Defines simplified communication between classes.
- √ Memento:-Capture and restore an object's internal state.
- √ Interpreter:-A way to include language elements in a program.
- √ Iterator:-Sequentially access the elements of a collection.
- √ Chain of Resp:-A way of passing a request between a chain of objects.
- √ Command:-Encapsulate a command request as an object.
- √ State:-Alter an object's behavior when its state changes.
- √ Strategy:-Encapsulates an algorithm inside a class.
- √ Observer:-A way of notifying change to a number of classes.
- √ Template Method:-Defer the exact steps of an algorithm to a subclass.
- √ Visitor:-Defines a new operation to a class without change.

Note :- Just remember Music..... 2 MICS On TV (MMIICSSOTV).

Note:- No source code is provided for architecture section as much of the things can be clear from good UML diagrams.

(A)What is the difference between Factory and Abstract Factory Patterns?

Note: - This is quiet a confusing architect question especially in design pattern section. Interviewer can take you for a nice ride. So get the difference in your heart.

First read the definition provided in the first question about both these patterns. The common thing they have is that they belong to creational patterns. In short they hide the complexity of creating objects.

The main difference between factory and Abstract factory is factory method uses inheritance to decide which object has to be instantiated while abstract factory uses delegation to decide instantiation of object. We can say Abstract factory uses factory

method to complete the architecture. Abstract Factory is one level higher in abstraction over Factory.

The two class diagrams below will provide overview of what is the actual difference. First figure shows a sample implementation of Factory Patterns. In this figure there are two basic sections:-

- √ The actual product section i.e. Class “Product” it inherits from an abstract class “AbstractProduct”.
- √ The creational aspect section i.e. “ConcreteCreator” class which inherits from class “Creator”.
- √ Now there are some rules the client will have to follow who will need the “Product” object. He will never refer directly to the actual “Product” object he will refer the “Product” object using “AbstractProduct”.
- √ Second client will never use “New” keyword to create the “Product” object but will use the “Creator” class which in turn will use the “ConcreteCreator” class to create the actual “Product” object.

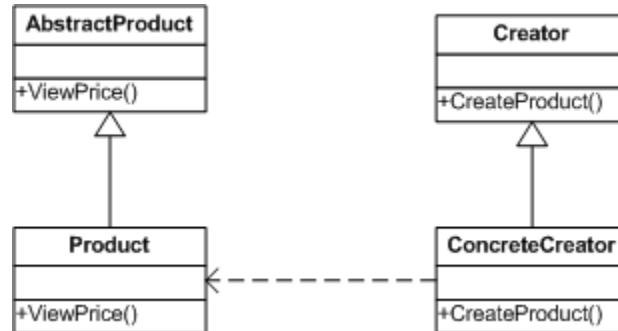

Figure: - 8.1 Class diagram of a factory Pattern

So what are the benefits from this architecture? All creational and initializing aspects are now detached from the actual client. As your creational aspect is now been handled in “ConcreteCreator” and the client has reference to only “Creator”, so any implementation change in “CreateProduct” will not affect the client code. In short now your creational aspect of object is completely encapsulated from the client’s logic.

Now let's look at the second class diagram which provides an overview of what actually "Abstract factory" pattern is. It creates objects for families of classes. In short it describes collection of factor methods from various different families. In short it groups related factory methods. Example in this the class "Creator" is implemented using the "Abstract" factory pattern. It now creates objects from multiple families rather one product.

Note :- Just stick up to this definition that Abstract factory classifies factory methods or groups logically related factory method together.

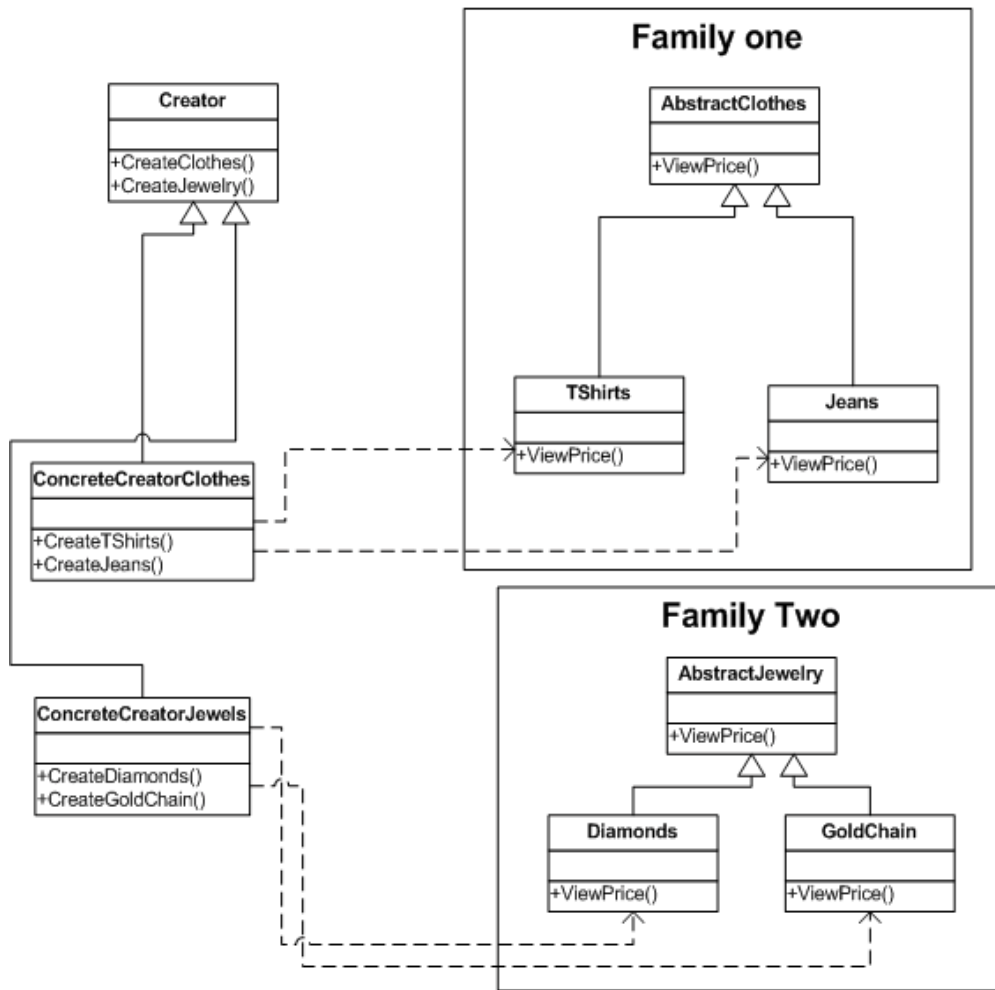

Figure:- 8.2 Class Diagram of Abstract Factory

(I)What is MVC pattern?

Twist: - How can you implement MVC pattern in ASP.NET?

The main purpose using MVC pattern is to decouple the GUI from the Data. It also gives the ability to provide multiple views for the same Data. MVC pattern separates objects in to three important sections:-

-
- √ Model: - This section is specially for maintaining data. It is actually where your business logic, querying database, database connection etc. is actually implemented.
 - √ Views: - Displaying all or some portion of data, or probably different view of data. View is responsible for look and feel, Sorting, formatting etc.
 - √ Controller: - They are event handling section which affects either the model or the view. Controller responds to the mouse or keyboard input to command model and view to change. Controllers are associated with views. User interaction triggers the events to change the model, which in turn calls some methods of model to update its state to notify other registered views to refresh their display.

Ok now this was all in theory. Let us look at how in actually ASP.NET we can implement MVC pattern. During interview with theory question they will be looking at have you really implemented MVC or its just talks. Following are the various sections of ASP.NET which maps to MVC sections:-

- √ Model: - This section is represented by Data view, Dataset, Typed Dataset, Business components, business entity models etc. Now this section can then be tied up to either windows application or web UI.
- √ View: - ASPX, ASCX, or windows application UI like data grid etc. form the view part of it.
- √ Controller: - In ASP.NET the behind code is the controller as the events are handled by that part. Controller communicates both with Model as well as view.

I hope I was able to map you imagination of ASP.NET with the diagram given below.

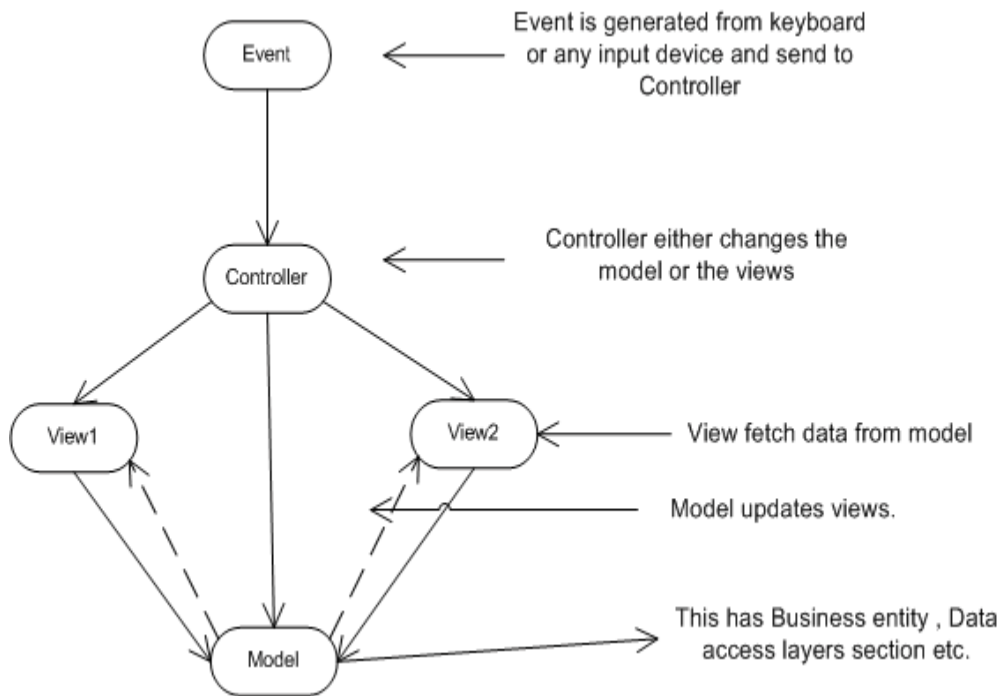

Figure: - 8. 3 Data flow between MVC architectures.

(A)How can we implement singleton pattern in .NET?

Singleton pattern mainly focuses on having one and only one instance of the object running. Example a windows directory service which has multiple entries but you can only have single instance of it through out the network.

Note:- May of developers would jump to a conclusion saying using the "STATIC" keyword we can have a single instance of object. But that's not the real case there is something more that has to be done. But please note we can not define a class as STATIC, so this will not serve our actual purpose of implementing singleton pattern.

Following are the three steps needed to implement singleton pattern in .NET:-

-
- √ First create your class with static members.

Public class ClsStaticClass

Private shared objCustomer as dsCustomer

End class

This ensures that there is actually only one Customer object throughout the project.

- √ Second define a private constructor to your class.

Note: - defining a private constructor to class does not allow a client to create objects directly.

- √ Finally provide a static method to get access to your singleton object.

(A)How do you implement prototype pattern in .NET?

Twist: - How to implement cloning in .NET ? What is shallow copy and deep copy ?

Cloning is achieved by using ICloneable of the System namespace. It has a “Clone” method which actually returns the reference of the same copy. Clone method allows a Shallow copy and not a deep copy. In Shallow copy if you make changes to the cloned object it actually changes on the main object itself. So how is deep copy achieved, by using “ISerializable” interface? So what you do is first serialize the object then deserialize back to a complete new copy. Now any changes to this new copy do not reflect on the original copy of the object, this is called as Deep copy.

(I)What are the situations you will use a Web Service and Remoting in projects?

Well “Web services” uses “remoting” concepts internally. But the major difference between “web service” and “remoting” is that “web service” can be consumed by clients who are not .NET platform. While remoting you need the client to be .NET compliant. Regarding the speed issue “Remoting” is faster than “Web Services”. So I think when deciding the architecture side of choosing between “Web services” and “Remoting” keep the cross platform issue and the speed issue in mind.

(A)Can you give a practical implementation of FAÇADE patterns?

Façade pattern sits on the top of lot of subsystems and makes access easy to interfaces of these subsystems. Basic purpose of Façade is to make interfacing between many modules and classes manageable.

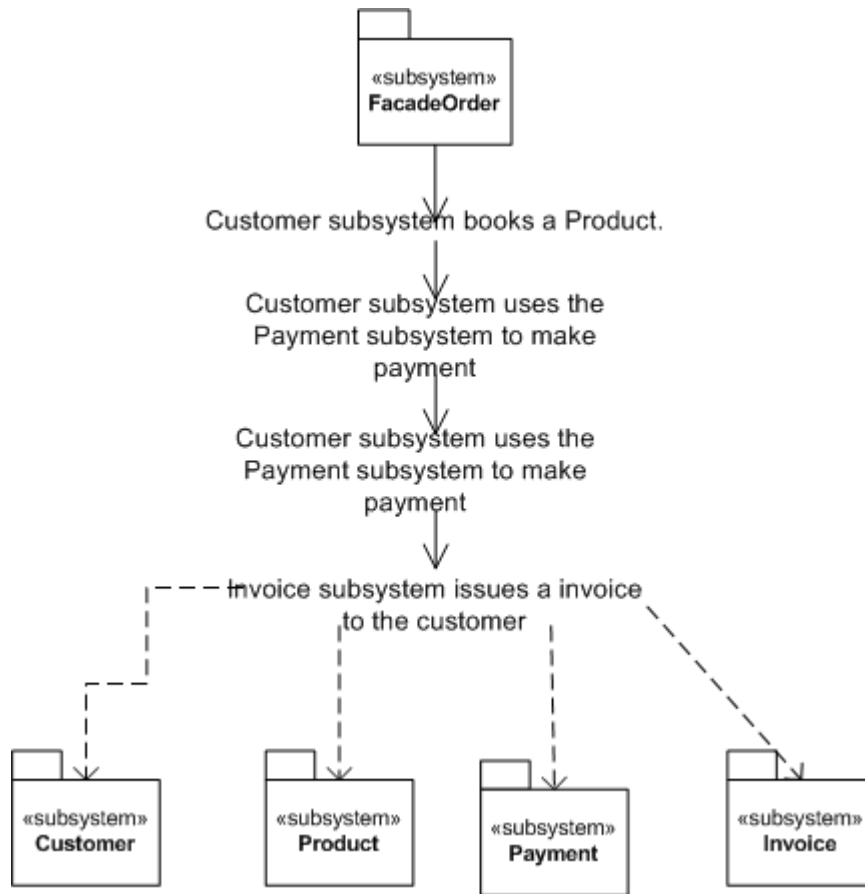

Figure: - 8.4 Façade in action

Above is a simple live application of a Façade class. In this we have four subsystems :-

- √ Customer
- √ Product

√ Payment

√ Invoicing

All the four modules when built at initial stage were built completely independent. The main interaction between all these subsystems is customer placing order. This functionality can be attained by using all these subsystems, which involves complex interaction between them.

That is where FAÇADE comes in to action. We have built a FAÇADE called as "FACADEORDER" which sits on the top of all these subsystem and fulfill our functionality.

(I) How can we implement observer pattern in .NET?

Observer patterns can be implemented using "Delegates" and "Events". I leave this to the readers to implement one sample code for observer patterns.

(B)What is three tier architecture?

The three tier software architecture emerged in the 1990s to overcome the limitations of the two tier architecture.

There are three layers when we talk about three tier architecture:-

User Interface (Client) :- This is mostly the windows user interface or the Web interface but this has only the UI part.

Mid layer: - Middle tier provides process management where business logic and rules are executed and can accommodate hundreds of users (as compared to only 100 users with the two tier architecture) by providing functions such as queuing, application execution, and database staging.

Data Access Layer: - This is also called by the famous acronym "DAL" component. It has mainly the SQL statement which do the database operation part of the job.

The three tier architecture is used when an effective distributed client/server design is needed that provides (when compared to the two tier) increased performance, flexibility, maintainability, reusability, and scalability, while hiding the complexity of distributed processing from the user.

(I)Have you ever worked with Microsoft Application Blocks, if yes then which?

Application Blocks are C# and VB.NET classes distributed as Visual Studio projects that can be downloaded from Microsoft's Web site and used in any .NET application, including ASP.NET Web applications. They are useful and powerful tools that can make applications more maintainable, scalable and efficient

Secondly which application blocks has been used depends on really what you have implemented. But there are two famous MAB which is making buzz around the industry:-

√ data access block

The Data Access Block provides static methods located in the SqlHelper class that encapsulates the most common data access tasks performed with Microsoft SQL server. If the term "static method" is new to you, it means that the class methods can be called without instantiating an instance of the class. For example, the method ExecuteReader () within the SqlHelper class can be called by simply using the statement SqlHelper.ExecuteReader () -- no object instantiation of the SqlHelper class is required.

√ Exception management block.

The Exception Management Application Block provides a simple yet extensible framework for handling exceptions. With a single line of application code you can easily log exception information to the Event Log or extend it by creating your own components that log exception details to other data sources or notify operators, without affecting your application code. The Exception Management Application Block can easily be used as a building block in your own .NET application

Note: - It's beyond the scope the book to look into details of application block. Best is go to www.microsoft.com and search for these application block. Try to compile one or two programs using their given classes and documentation.

(A)What is Service Oriented architecture?

“Services” are components which expose well defined interfaces and these interfaces communicate through XML messages. Using SOA you can build workflow, which uses

interfaces of these components. SOA is typically useful when you are crossing heterogeneous technical boundaries, organizations, domain etc.

In .NET SOA technically uses Web services to communicate with each service which is crossing boundaries. You can look SOA which sits on top of web services and provides a workflow.

SOA uses service components which operate in their own domain boundary. Let us note some points of service :-

- √ They are independent components and operate in their own boundary and own technology.
- √ They have well defined interfaces which use XML and WSDL to describe themselves.
- √ Services have URL where anyone can find them and clients can bind to these URL to avail for the service.
- √ Services have very loosely coupled architecture. In order to communicate to service you only have to know the WSDL. Your client can then generate proxy from the WSDL of the service.

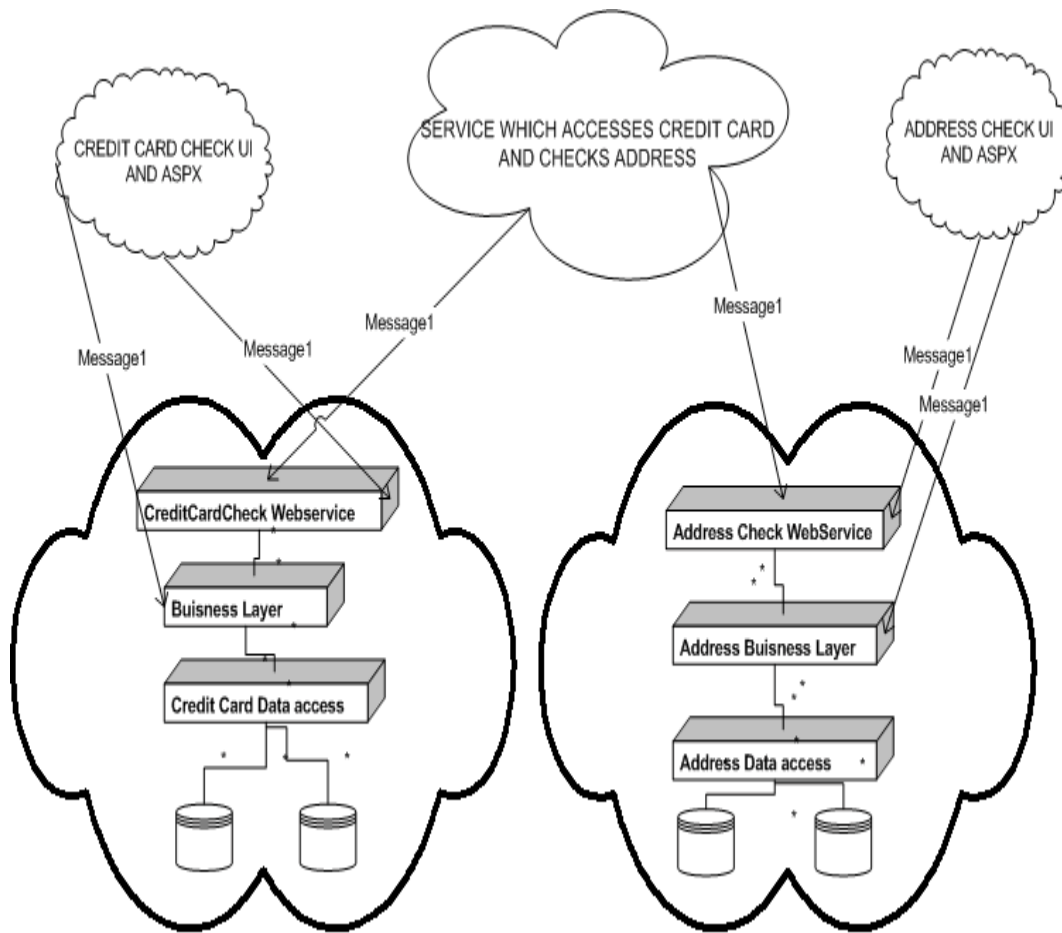

Figure: - 8.5 SOA basic architecture

Above figure describes a broader picture of what service oriented architecture will look like. The basic fundamental of SOA is a web service. In above diagram you can see there are two services available. One is the “Credit Card” service and other is “Address Check”

web service. Both these services are provided by different company. Now we want to build a functionality which needs to validate a credit card and also check that addresses are proper. In short we will need functionalities of both the “CreditCard” and “AddressCheck” service. Also note the “CreditCard” service has its own business layer and DAL components, which can be in a proprietary language. It’s very much possible that the whole Credit card service is made in .NET and the Address check is SAP implementation or JAVA implementation. But because both the systems provide there functionality using Web services which is nothing but basically XML message communication. So we have made new service which sits like a FAÇADE on top of both the web service and performs both functionalities in one common service. You will see I have made a third service which sits on top of both the webservice and consumes them. Also you can see that the UI part of the systems have access to Business layer and Web service of there system. But the service which does both these check has only access to the Web service.

Note:- It’s beyond the scope of this book to discuss about SOA. But just to keep you safe during interview this book has tried to clear some basics of SOA. I will really stress you to read WCF chapter of this book which talks in detail of how microsoft has visualized SOA.

(I)What are different ways you can pass data between tiers?

There are many ways you can pass data between tiers :-

- √ Dataset the most preferred one as they maintain data in XML format.
- √ Datareader
- √ Custom classes.
- √ XML

(A)What is Windows DNA architecture?

Note :- If you have worked with classic ASP this question can come to you.

The Windows Distributed interNet Applications Architecture (DNA) is a Microsoft blueprint for robust, scalable, distributed business software. Windows DNA has evolved over time and was not preplanned. It gives all combined advantages of Centralized mainframe, application servers, internet technologies and Personal computers. Windows DNA is an evolution which started from mainframes (where all logic was centralized), Fox pro ages (where we talked in terms of two tier systems), VB6 / SQL SERVER (three tier where we talked in terms of having one more tier which was mainly COM where business logic resided), COM+ (looking in terms of transactions and fulfilling ACID rules) and finally the DNA.

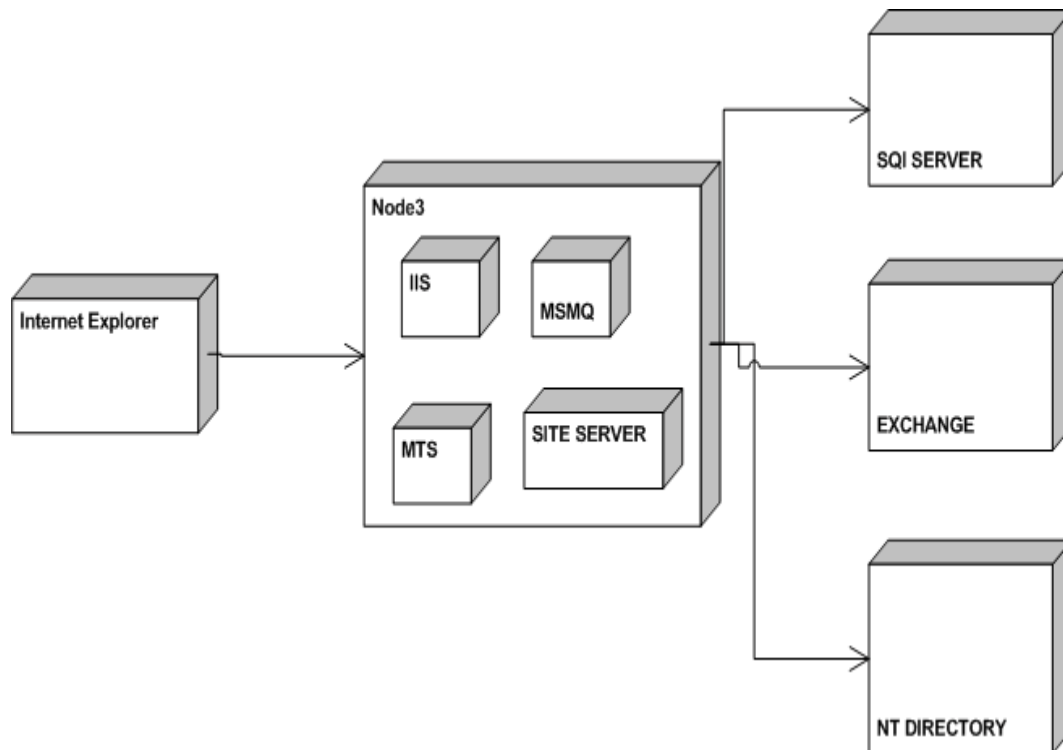

Figure :- 8.6 Windows DNA sections

Above shown is a Windows DNA model which is a blue print which Microsoft has proposed. So if interviewer is asking you have you worked with Windows DNA, then answer is yes. You will see that you always use these sections in project. Do not get confused with the terminology DNA.

(A)What is aspect oriented programming?

Note :- This is something which is catching up the market so interviewer can ask you to see how you are in touch with the market. So probably this explanation can be quiet long but bear with me it is worth of it

I will try and make it as short as possible as this book is not a reference book. Just to save you from interviewer I will give a short description of aspect oriented programming in .NET.

First let us try and define it which can probably save you during interview

Aspect-oriented software development is a new technology for separation of concerns (SOC) in software development. The techniques of AOSD make it possible to modularize crosscutting aspects of a system.

Ok that statement can save you for the first stage let us get down actually what is it. Let's revisit back how software development cycle evolved.

When we look back at times of COBOL where we used to break the modules in small functionalities and use reusability to its maximum.

Then came the time when we talked in terms of Objects where things were clearer as software was modeled in terms of real life examples. It worked fine and till today is the most accepted way of implementing and organizing project. So why AOP ??

Aspect oriented programming does not oppose OOP's but rather supports it and make's it more maintainable. So remove the logic from head the AOP is replacement of OOP. No its brother of OOP helping him to be better.

When we talk in terms of objects it is an entity which maps to real world domain. Object has attributes which represent the state of object and also define its behavior. By rule of object oriented programming object should be stand alone and communicate with other objects using messages or defined interface.

One object should not communicate with other object directly rather communicate through defined interfaces. Every object satisfies some "Concern" in relation to the system.

Twist: - What is Concern in AOP?

“A concern is a particular goal, concept, or area of interest”

There are mainly two types of concern from an object perspective:-

- √ Core / Main concerns which it should satisfy and is his work.
- √ System concerns which are not related to business functionalities but software related concerns example audit trail, Error handling, Security etc.

Ok let us try to understand this principle by some actual example.

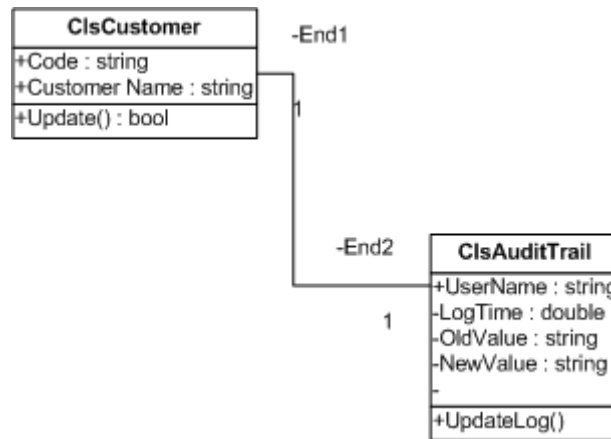

Figure :- 8.7 Customer and Audit trail relationships

Above is a class diagram which shows relationship between two classes “ClsCustomer” and “ClsAuditTrail”. “ClsCustomer” class does inserting of new customers in to database and “ClsAuditTrail” does the auditing of what is changed in the customer class.

Now there are two concerns in this project :-

- √ Customer code should not exceed than 10 lengths (Business level concern) greater
- √ All customer data which is updated should be audited. (System level concern)

Here goes the class code. If you see the ClsCustomer implementation in the update method I have called the Audit trail implementation. If you really look from object oriented point of view we are doing something in customer class which is supposed to be not his implementation: - Audit Trail logging. Thus we have also broken down the rule of encapsulation. In short the class not only handles his work but also some other work which is not his concern.

Ok now let us define crosscutting which is one of important aspects of AOP.

Twist :- What is cross cutting in AOP ?

When one or many concerns span across module it is called as cross cutting. Example in our audit trail example we will probably need to audit trail for customer as well as supplier. So Audit trail can span across other objects also that is termed as cross cutting.

Below are both the classes actually implemented as per class diagram 8.7. If you see the “Update” method of the customer class, its doing both of the concerns that is checking for customer code length and also maintaining the audit trail using the audit trail class.

Public Class ClsCustomer

Private pstrCustcode As String

Private pstrCustName As String

Public Property Code() As String

Get

Return pstrCustcode

End Get

Set(ByVal Value As String)

pstrCustcode = Value

End Set

End Property

Public Property CustomerName() As String

Get

Return pstrCustName

```
End Get  
Set(ByVal Value As String)  
  
    pstrCustName = Value  
End Set  
End Property  
Public Function Update() As Boolean  
    ' first / core concern  
    If pstrCustcode.Length() > 10 Then  
        Throw New Exception("Value can not be greater than 10")  
End If  
  
    ' using the customer audit trail to do auditing  
    ' second concern / system concern  
Dim pObjClsAuditTrail As New ClsAuditTrail  
With pObjClsAuditTrail  
    .NewValue = "1001"  
    .OldValue = "1003"  
    .UserName = "shiv"  
    .Update()  
End With  
  
    ' then inserting the customer in database  
End Function  
End Class  
Public Class ClsAuditTrail  
    Private pstrUserName As String
```

```
Private pstrOldValue As String
Private pstrNewValue As String
Private pdblLogTime As Double
Public Property UserName() As String
    Get
        Return pstrUserName
    End Get
    Set(ByVal Value As String)
        pstrUserName = Value
    End Set
End Property
Public Property OldValue() As String
    Get
        Return pstrOldValue
    End Get
    Set(ByVal Value As String)
        pstrOldValue = Value
    End Set
End Property
Public Property NewValue() As String
    Get
        Return pstrNewValue
    End Get
    Set(ByVal Value As String)
        pstrNewValue = Value
```

```
        End Set
    End Property
    Public Property LogTime() As Double
        Get
            Return pdblLogTime
        End Get
        Set(ByVal Value As Double)
            pdblLogTime = Value
        End Set
    End Property
    Public Sub Update()
        ' do the logging activity here
    End Sub
End Class
```

In short the customer class is doing many activity. There is lot of tangling of code. So how do we overcome this problem...? Simple, separate the System level concern (Audit Trail) from the core level concern (Customer code check). This is achieved at this moment in .NET using attribute programming.

Here is the change to the customer class

```
Imports System.Reflection
Public Class ClsCustomer
    Private pstrCustcode As String
    Private pstrCustName As String
    Public Property Code() As String
        Get
            Return pstrCustcode
```

```
End Get
  Set(ByVal Value As String)

      pstrCustcode = Value
  End Set
End Property
Public Property CustomerName() As String
  Get
      Return pstrCustName
  End Get
  Set(ByVal Value As String)

      pstrCustName = Value
  End Set
End Property
  <ClsAuditTrail("Shiv", "1001", "1003", 12)> _
Public Function Update() As Boolean
  If pstrCustcode.Length() > 10 Then
      Throw New Exception("Value can not be greater than 10")
  End If
  ' using the customer audit trail to do auditing

  ' then inserting the customer in database
```

End Function

End Class

And here is the change to the audit trail class

Imports System.Reflection

<AttributeUsage(AttributeTargets.All)> _

Public Class ClsAuditTrail

Inherits Attribute

Private pstrUserName As String

Private pstrOldValue As String

Private pstrNewValue As String

Private pdblLogTime As Double

Public Property UserName() As String

Get

Return pstrUserName

End Get

Set(ByVal Value As String)

pstrUserName = Value

End Set

End Property

Public Property OldValue() As String

Get

Return pstrOldValue

End Get

```
    Set(ByVal Value As String)
        pstrOldValue = Value
    End Set
End Property
Public Property NewValue() As String
    Get
        Return pstrNewValue
    End Get
    Set(ByVal Value As String)
        pstrNewValue = Value
    End Set
End Property
Public Property LogTime() As Double
    Get
        Return pdblLogTime
    End Get
    Set(ByVal Value As Double)
        pdblLogTime = Value
    End Set
End Property
Public Sub New(ByVal pstrUserName As String, _
        ByVal pstrOldValue As String, _
        ByVal pstrnewValue As String, _
        ByVal plng As Long)
    Update()
End Sub
```

```
Public Sub Update()
```

9 . ADO .NET

(B)What is the namespace in which .NET has the data functionality classes ?

Following are the namespaces provided by .NET for data management :-

System.data

This contains the basic objects used for accessing and storing relational data, such as DataSet, DataTable, and DataRelation. Each of these is independent of the type of data source and the way we connect to it.

System.Data.OleDb

It contains the objects that we use to connect to a data source via an OLE-DB provider, such as OleDbConnection, OleDbCommand, etc. These objects inherit from the common base classes, and so have the same properties, methods, and events as the SqlConnection equivalents.

System.Data.SqlClient:

This contains the objects that we use to connect to a data source via the Tabular Data Stream (TDS) interface of Microsoft SQL Server (only). This can generally provide better performance as it removes some of the intermediate layers required by an OLE-DB connection.

System.XML

This Contains the basic objects required to create, read, store, write, and manipulate XML documents according to W3C recommendations.

(B) Can you give a overview of ADO.NET architecture ?

The most important section in ADO.NET architecture is “Data Provider”. Data Provider provides access to datasource (SQL SERVER, ACCESS, ORACLE).In short it provides object to achieve functionalities like opening and closing connection, retrieve data and update data. In the below figure you can see the four main sections of a data provider :-

√ Connection.

-
- √ Command object (This is the responsible object to use stored procedures)
 - √ Data Adapter (This object acts as a bridge between data store and dataset).
 - √ Datareader (This object reads data from data store in forward only mode).

Dataset object represents disconnected and cached data. If you see the diagram it is not in direct connection with the data store (SQL SERVER, ORACLE etc) rather it talks with Data adapter, who is responsible for filling the dataset. Dataset can have one or more Datable and relations.

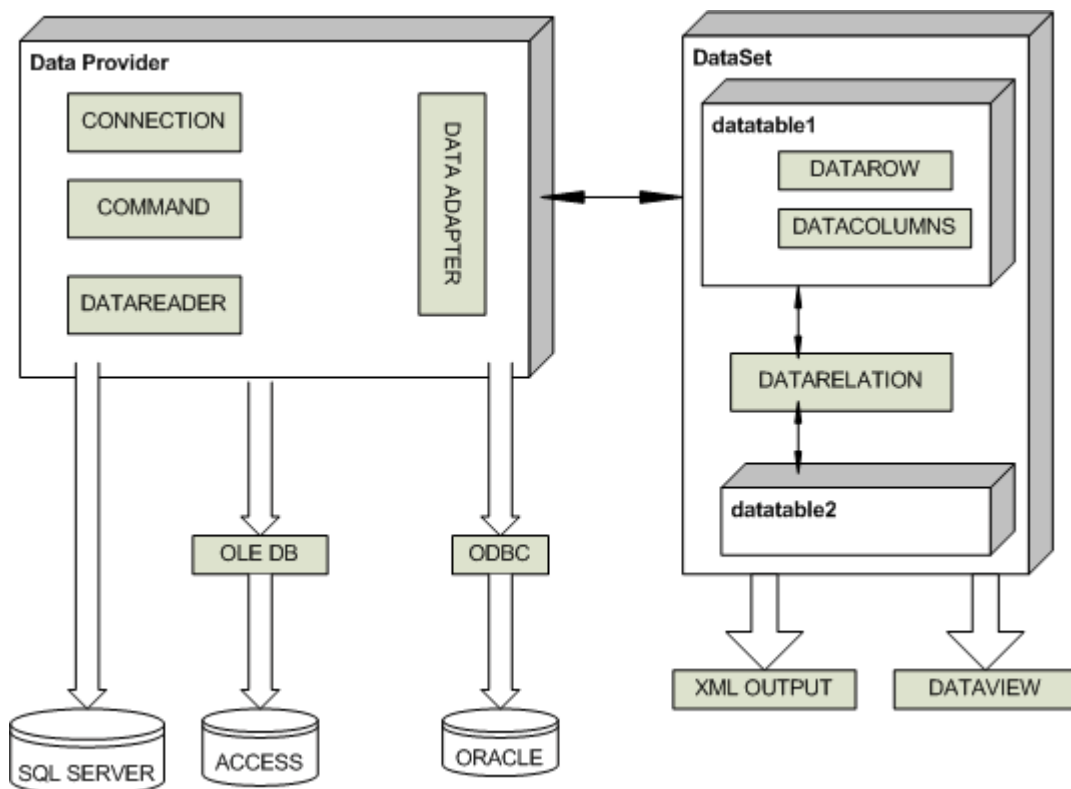

Figure :- 9.1 ADO.NET Architecture

“DataView” object is used to sort and filter data in Datatable.

Note:- This is one of the favorite questions in .NET. Just paste the picture in your mind and during interview try to refer that image.

(B)What are the two fundamental objects in ADO.NET ?

Datareader and Dataset are the two fundamental objects in ADO.NET.

(B)What is difference between dataset and datareader ?

Following are some major differences between dataset and datareader :-

- √ DataReader provides forward-only and read-only access to data, while the DataSet object can hold more than one table (in other words more than one rowset) from the same data source as well as the relationships between them.
- √ Dataset is a disconnected architecture while datareader is connected architecture.
- √ Dataset can persist contents while datareader can not persist contents, they are forward only.

(I)What are major difference between classic ADO and ADO.NET ?

Following are some major differences between both

- √ As in classic ADO we had client and server side cursors they are no more present in ADO.NET. Note it's a disconnected model so they are no more applicable.
- √ Locking is not supported due to disconnected model.
- √ All data persist in XML as compared to classic ADO where data persisted in Binary format also.

(B)What is the use of connection object ?

They are used to connect a data to a Command object.

- √ An OleDbConnection object is used with an OLE-DB provider

-
- √ A SqlConnection object uses Tabular Data Services (TDS) with MS SQL Server

(B)What is the use of command objects ?

They are used to connect connection object to Datareader or dataset. Following are the methods provided by command object :-

- √ ExecuteNonQuery :- Executes the command defined in the CommandText property against the connection defined in the Connection property for a query that does not return any row (an UPDATE, DELETE or INSERT). Returns an Integer indicating the number of rows affected by the query.
- √ ExecuteReader :- Executes the command defined in the CommandText property against the connection defined in the Connection property. Returns a "reader" object that is connected to the resulting rowset within the database, allowing the rows to be retrieved.
- √ ExecuteScalar :- Executes the command defined in the CommandText property against the connection defined in the Connection property. Returns only single value (effectively the first column of the first row of the resulting rowset) any other returned columns and rows are discarded. It is fast and efficient when only a "singleton" value is required

(B)What is the use of dataadapter ?

These are objects that connect one or more Command objects to a DataSet object. They provide logic that would get data from the data store and populates the tables in the DataSet, or pushes the changes in the DataSet back into the data store.

- √ An OleDbDataAdapter object is used with an OLE-DB provider
- √ A SqlDataAdapter object uses Tabular Data Services with MS SQL Server.

(B)What are basic methods of Dataadapter ?

There are three most commonly used methods of Dataadapter :-

Fill :- Executes the SelectCommand to fill the DataSet object with data from the data source. It can also be used to update (refresh) an existing table in a DataSet with changes made to the data in the original datasource if there is a primary key in the table in the DataSet.

FillSchema :- Uses the **SelectCommand** to extract just the schema for a table from the data source, and creates an empty table in the **DataSet** object with all the corresponding constraints.

Update:- Calls the respective **InsertCommand**, **UpdateCommand**, or **DeleteCommand** for each inserted, updated, or deleted row in the **DataSet** so as to update the original data source with the changes made to the content of the **DataSet**. This is a little like the **UpdateBatch** method provided by the **ADO Recordset** object, but in the **DataSet** it can be used to update more than one table.

(B)What is Dataset object?

The **DataSet** provides the basis for disconnected storage and manipulation of relational data. We fill it from a data store, work with it while disconnected from that data store, then reconnect and flush changes back to the data store if required.

(B)What are the various objects in Dataset ?

Dataset has a collection of **DataTable** object within the **Tables** collection. Each **DataTable** object contains a collection of **DataRow** objects and a collection of **DataColumn** objects. There are also collections for the primary keys, constraints, and default values used in this table which is called as constraint collection, and the parent and child relationships between the tables. Finally, there is a **DefaultView** object for each table. This is used to create a **DataView** object based on the table, so that the data can be searched, filtered or otherwise manipulated while displaying the data.

Note :- Look back again to the main diagram for ADO.NET architecture for visualizing this answer in pictorial form.

(B) How can we connect to Microsoft Access , Foxpro , Oracle etc ?

Microsoft provides **System.Data.OleDb** namespace to communicate with databases like **Access** , **Oracle** etc. In short any **OLE DB-Compliant** database can be connected using **System.Data.OleDb** namespace.

Note :- Small sample of OLEDB is provided in "WindowsAppOleDb" which uses "Nwind.mdb" in bin directory to display data in Listbox.

```
Private Sub loadData()
```

```

Dim strPath As String
strPath = AppDomain.CurrentDomain.BaseDirectory
Dim objOLEDBCon As New
OleDbConnection("Provider=Microsoft.Jet.OLEDB.4.0;Data Source =" &
strPath & "Nwind.mdb")
Dim objOLEDBCommand As OleDbCommand
Dim objOLEDBReader As OleDbDataReader
Try

    objOLEDBCommand = New OleDbCommand("Select FirstName
from Employees")
objOLEDBCon.Open()
objOLEDBCommand.Connection = objOLEDBCon
objOLEDBReader = objOLEDBCommand.ExecuteReader()
Do While objOLEDBReader.Read()
    lstNorthwinds.Items.Add(objOLEDBReader.GetString(0))
Loop
Catch ex As Exception
    Throw ex
Finally
    objOLEDBCon.Close()
End Try

End Sub

```

The main heart is the "Loaddata()" method which actually loads the data in listbox.

Note:- This source code has the connectionstring hard coded in the program itself which is not a good programming practice. For windows application the best place to store connectionstring is "App.config". Also note that "AppDomain.CurrentDomain.BaseDirectory" function gives the current path of the running exe which is "BIN" and the MDB file is in that directory. Also note that the final block which executes irrespective that there is error or not. Thus ensuring that all the connection to the datastore is freed. Its best practice to put all clean up statements in finally block thus ensuring that the resources are deallocated properly.

(B) How do we connect to SQL SERVER, which namespace do we use ?

Below is the code, after the code I have given the explanation for it. For this sample we will also need a SQL Table setup which I have imported using the DTS wizard.

```

Private Sub LoadData()
    ' note :- with and end with makes your code more readable
    Dim strConnectionString As String
    Dim objConnection As New SqlConnection
    Dim objCommand As New SqlCommand
    Dim objReader As SqlDataReader
    Try
        ' this gets the connectionstring from the app.config
file.
        ' note if this gives error see where the MDB file is
stored in your pc and point to that
        strConnectionString =
AppSettings.Item("ConnectionString")
        ' take the connectiostring and initialize the connection
object
        With objConnection
            .ConnectionString = strConnectionString
            .Open()
        End With
        objCommand = New SqlCommand("Select FirstName from
Employees")
        With objCommand
            .Connection = objConnection
            objReader = .ExecuteReader()
        End With
        ' looping through the reader to fill the list box
        Do While objReader.Read()
            lstData.Items.Add(objReader.Item("FirstName"))
        Loop
        Catch ex As Exception
            Throw ex
        Finally
            objConnection.Close()
        End Try
    
```

```

<appSettings>
    <add key="ConnectionString" value="Server=ERMBOM1-IT2;User
ID=sa;Database=Employees"/>
</appSettings>

```

Note:- The above code is provided in CD in folder WindowsAppSqlClient". Comments in the code do explain a lot but we will again iterate through the whole code later. "LoadData" is the main method which loads the data from SQL SERVER. Before running this code you have to install SQL SERVER in your machine. As we are dealing

with SQLCLIENT we need to setup database in SQL SERVER. For this sample I have imported access “Nwind.mdb” in “SampleAccessDatabase” folder in CD in to SQISERVER. Depending on computer you will also have to change the connectionstring in Web.config file.

For setting up the sample SQL table we can use the DTS import wizard to import the table. See the below figure which is using data source as Microsoft Access. While importing the database author had give the database name as “Employees”.

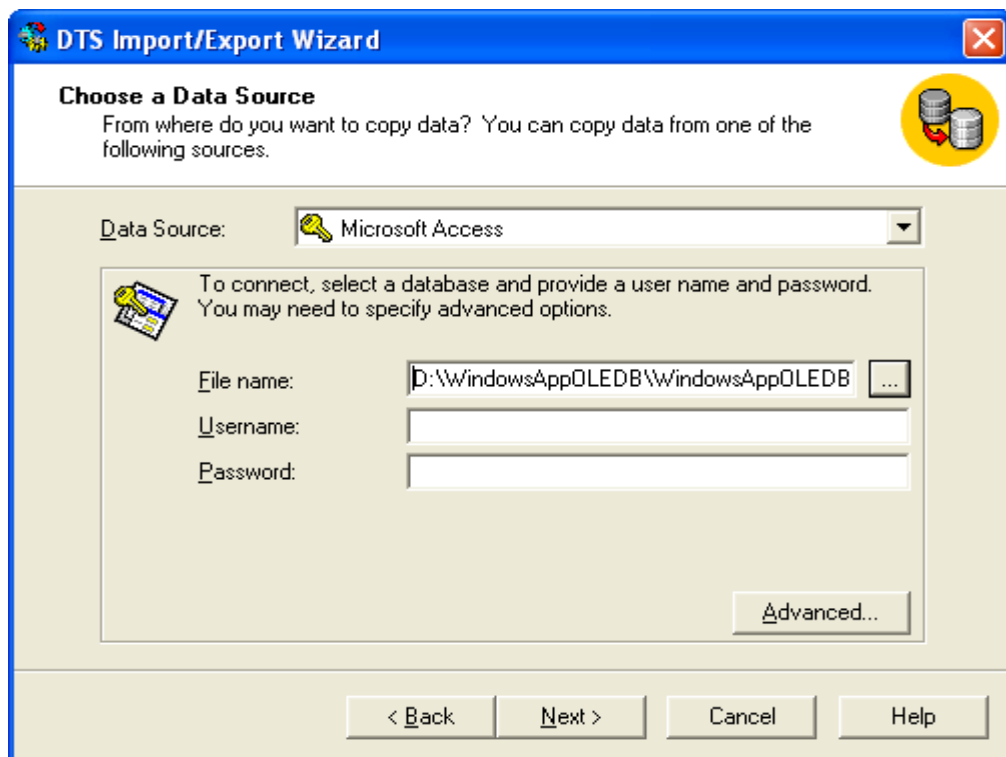

Figure:- 9.2 Loading “Nwind.mdb” in SQL SERVER for the sample

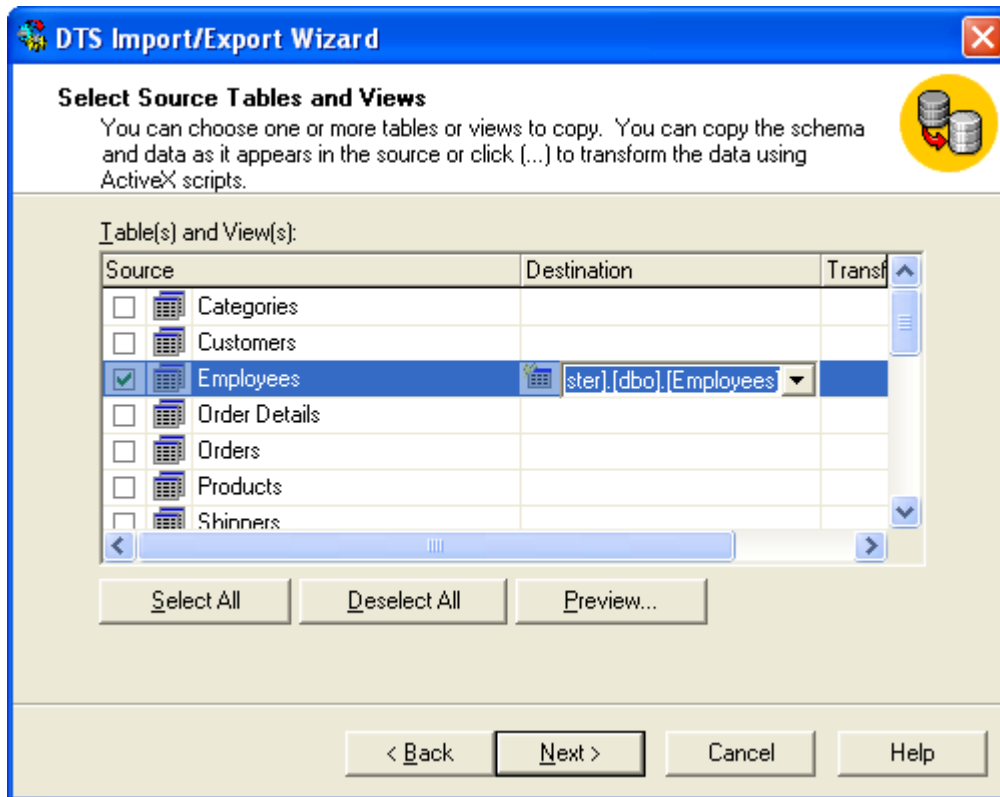

Figure :- 9.3 Load only the Employee table.

To make it simple we will only import the employee table as that is the only thing needed in our sample code.

EmployeeID	LastName	FirstName	Title
1	Davolio	Nancy	Sales Representati
2	Fuller	Andrew	Vice President, Sale
3	Leverling	Janet	Sales Representati
4	Peacock	Margaret	Sales Representati
5	Buchanan	Steven	Sales Manager
6	Suyama	Michael	Sales Representati
7	King	Robert	Sales Representati
8	Callahan	Laura	Inside Sales Coordi
9	Dodsworth	Anne	Sales Representati

Figure :- 9.4 View of loaded Employee table

Now from interview point of view definitely you are not going to say the whole source code which is given in the book. Interviewer expects only the broader answer of what are the steps needed to connect to SQL SERVER. For fundamental sake author has explained the whole source code. In short you have to explain the “LoadData” method in broader way. Following are the steps to connect to SQL SERVER :-

- √ First import the namespace “System.Data.SqlClient”.
- √ Create a connection object as shown in “LoadData” method.

```
With objConnection
    .ConnectionString = strConnectionString
    .Open()
End With
```

- √ Create the command object with the SQL. Also assign the created connection object to command object and execute the reader.

```
objCommand = New SqlCommand("Select FirstName from Employees")
    With objCommand
        .Connection = objConnection
        objReader = .ExecuteReader()
    End With
```

- √ Finally loop through the reader and fill the list box. If old VB programmers are expecting the `movenext` command it's replaced by `Read()` which returns true if there is any data to be read. If the `.Read()` return's false that means that it's end of datareader and there is no more data to be read.

```
Do While objReader.Read()
    lstData.Items.Add(objReader.Item("FirstName"))
Loop
```

- √ Do not forget to close the connection object.

Note:- In "LoadData" you will see that connectionstring is stored in Web.config file and is loaded using "AppSettings.Item("ConnectionString)". While running this sample live on your database do not forget to change this connectionstring accordingly to your machine name and SQL SERVER or else the source code will not run.

(B) How do we use stored procedure in ADO.NET and how do we provide parameters to the stored procedures?

ADO.NET provides the `SqlCommand` object which provides the functionality of executing stored procedures.

Note :- Sample code is provided in folder "WindowsSqlClientCommand". There are two stored procedures created in same database "Employees" which was created for the previous question.

```
CREATE PROCEDURE SelectByEmployee @FirstName nvarchar(200) AS
```

```
Select FirstName from Employees where FirstName like @FirstName + '%'
```

```
CREATE PROCEDURE SelectEmployee AS
```

```
Select FirstName from Employees
```

```
If txtEmployeeName.Text.Length = 0 Then
    objCommand = New SqlCommand("SelectEmployee")
Else
    objCommand = New SqlCommand("SelectByEmployee")
```

```
        objCommand.Parameters.Add( "@FirstName" ,  
Data.SqlDbType.NVarChar, 200 )  
        objCommand.Parameters.Item( "@FirstName" ).Value =  
txtEmployeeName.Text.Trim()  
    End If
```

In the above sample not much has been changed only that the SQL is moved to the stored procedures. There are two stored procedures one is "SelectEmployee" which selects all the employees and the other is "SelectByEmployee" which returns employee name starting with a specific character. As you can see to provide parameters to the stored procedures we are using the parameter object of the command object. In such question interviewer expects two simple answers one is that we use command object to execute stored procedures and the parameter object to provide parameter to the stored procedure. Above sample is provided only for getting the actual feel of it. Be short be nice and get a job.

(B) How can we force the connection object to close after my datareader is closed ?

Command method Executereader takes a parameter called as CommandBehavior where in we can specify saying close connection automatically after the Datareader is close.

```
pobjDataReader = pObjCommand.ExecuteReader(CommandBehavior.CloseConnection)
```

(B) I want to force the datareader to return only schema of the datastore rather than data ?

```
pobjDataReader = pObjCommand.ExecuteReader(CommandBehavior.SchemaOnly)
```

(B) How can we fine tune the command object when we are expecting a single row ?

Again CommandBehaviour enumeration provides two values SingleResult and SingleRow. If you are expecting a single value then pass "CommandBehaviour.SingleResult" and the query is optimized accordingly, if you are expecting single row then pass "CommandBehaviour.SingleRow" and query is optimized according to single row.

(B) Which is the best place to store connectionstring in .NET projects ?

Config files are the best places to store connectionstrings. If it is a web-based application “Web.config” file will be used and if it is a windows application “App.config” files will be used.

(B) What are the steps involved to fill a dataset ?

Twist :- How can we use dataadapter to fill a dataset ?

Sample code is provided in “WindowsDataSetSample” folder in CD.”LoadData” has all the implementation of connecting and loading to dataset. This dataset is finally bind to a ListBox. Below is the sample code.

```
Private Sub LoadData()  
    Dim strConnectionString As String  
    strConnectionString = AppSettings.Item("ConnectionString")  
    Dim objConn As New SqlConnection(strConnectionString)  
    objConn.Open()  
    Dim objCommand As New SqlCommand("Select FirstName from  
Employees")  
    objCommand.Connection = objConn  
    Dim objDataAdapter As New SqlDataAdapter()  
    objDataAdapter.SelectCommand = objCommand  
    Dim objDataSet As New DataSet  
  
End Sub
```

In such type of questions interviewer is looking from practical angle, that have you worked with dataset and dataadapters. Let me try to explain the above code first and then we move to what steps should be told during interview.

```
Dim objConn As New SqlConnection(strConnectionString)  
objConn.Open()
```

First step is to open the connection. Again note the connection string is loaded from config file.

```
Dim objCommand As New SqlCommand("Select FirstName from Employees")  
objCommand.Connection = objConn
```

Second step is to create a command object with appropriate SQL and set the connection object to this command.

```
Dim objDataAdapter As New SqlDataAdapter()
```

objDataAdapter.SelectCommand = objCommand

Third step is to create the Adapter object and pass the command object to the adapter object.

objDataAdapter.Fill(objDataSet)

Fourth step is to load the dataset using the "Fill" method of the dataadapter.

lstData.DataSource = objDataSet.Tables(0).DefaultView

lstData.DisplayMember = "FirstName"

lstData.ValueMember = "FirstName"

Fifth step is to bind to the loaded dataset with the GUI. At this moment sample has listbox as the UI. Binding of the UI is done by using DefaultView of the dataset. Just to revise every dataset has tables and every table has views. In this sample we have only loaded one table i.e. Employees table so we are referring that with an index of zero.

Just say all the five steps during interview and you will see the smile on the interviewer's face and appointment letter in your hand.

(B)What are the various methods provided by the dataset object to generate XML?

Note:- XML is one of the most important leap between classic ADO and ADO.NET. So this question is normally asked more generally how can we convert any data to XML format. Best answer is convert in to dataset and use the below methods.

√ ReadXML

Read's a XML document in to Dataset.

√ GetXML

This is a function which returns the string containing XML document.

√ WriteXML

This writes a XML data to disk.

(B) How can we save all data from dataset ?

Dataset has “AcceptChanges” method which commits all the changes since last time “Acceptchanges” has been executed.

Note :- This book does not have any sample of Acceptchanges. I leave that to readers as homework sample. But yes from interview aspect that will be enough.

(B) How can we check that some changes have been made to dataset since it was loaded ?

Twist :- How can we cancel all changes done in dataset ?

Twist :- How do we get values which are changed in a dataset ?

For tracking down changes Dataset has two methods which comes as rescue “GetChanges” and “HasChanges”.

GetChanges

Returns dataset which are changed since it was loaded or since Acceptchanges was executed.

HasChanges

This property indicates that has any changes been made since the dataset was loaded or acceptchanges method was executed.

If we want to revert or abandon all changes since the dataset was loaded use “RejectChanges”.

Note:- One of the most misunderstood things about these properties is that it tracks the changes of actual database. That is a fundamental mistake; actually the changes are related to only changes with dataset and have nothing to with changes happening in actual database. As dataset are disconnected and do not know anything about the changes happening in actual database.

(B) How can we add/remove row’s in “DataTable” object of “DataSet” ?

“Datatable” provides “NewRow” method to add new row to “DataTable”. “DataTable” has “DataRowCollection” object which has all rows in a “DataTable” object. Following are the methods provided by “DataRowCollection” object :-

Add

Adds a new row in DataTable

Remove

It removes a “DataRow” object from “DataTable”

RemoveAt

It removes a “DataRow” object from “DataTable” depending on index position of the “DataTable”.

(B) What is basic use of “DataView” ?

“DataView” represents a complete table or can be small section of rows depending on some criteria. It is best used for sorting and finding data with in “datatable”.

Dataview has the following method's :-

Find

It takes a array of values and returns the index of the row.

FindRow

This also takes array of values but returns a collection of “DataRow”.

If we want to manipulate data of “DataTable” object create “DataView” (Using the “DefaultView” we can create “DataView” object) of the “DataTable” object and use the following functionalities :-

AddNew

Adds a new row to the “DataView” object.

Delete

Deletes the specified row from “DataView” object.

(B) What is the difference between “DataSet” and “DataReader” ?

Twist :- Why is DataSet slower than DataReader ?

Fourth point is the answer to the twist.

Note:- This is my best question and I expect everyone to answer it. It is asked almost 99% in all companies....Basic very Basic cram it.

Following are the major differences between “DataSet” and “DataReader” :-

- √ “DataSet” is a disconnected architecture, while “DataReader” has live connection while reading data. If we want to cache data and pass to a different tier “DataSet” forms the best choice and it has decent XML support.
- √ When application needs to access data from more than one table “DataSet” forms the best choice.
- √ If we need to move back while reading records, “datareader” does not support this functionality.
- √ But one of the biggest drawbacks of DataSet is speed. As “DataSet” carry considerable overhead because of relations, multiple tables etc speed is slower than “DataReader”. Always try to use “DataReader” wherever possible, as it's meant specially for speed performance.

(B) How can we load multiple tables in a DataSet ?

objCommand.CommandText = "Table1"

```
objDataAdapter.Fill(objDataSet, "Table1")
```

```
objCommand.CommandText = "Table2"
```

```
objDataAdapter.Fill(objDataSet, "Table2")
```

Above is a sample code which shows how to load multiple “DataTable” objects in one “DataSet” object. Sample code shows two tables “Table1” and “Table2” in object ObjDataSet.

```
lstdata.DataSource = objDataSet.Tables("Table1").DefaultView
```

In order to refer “Table1” DataTable, use Tables collection of DataSet and the Defaultview object will give you the necessary output.

(B) How can we add relation’s between table in a DataSet ?

```
Dim objRelation As DataRelation
```

```
objRelation=New
```

```
DataRelation("CustomerAddresses",objDataSet.Tables("Customer").Columns("Custid")
```

```
,objDataSet.Tables("Addresses").Columns("Custid_fk"))
```

```
objDataSet.Relations.Add(objRelation)
```

Relations can be added between “DataTable” objects using the “DataRelation” object. Above sample code is trying to build a relationship between “Customer” and “Addresses” “Datatable” using “CustomerAddresses” “DataRelation” object.

(B) What is the use of CommandBuilder ?

CommandBuilder builds “Parameter” objects automatically. Below is a simple code which uses commandbuilder to load its parameter objects.

```
Dim pObjCommandBuilder As New OleDbCommandBuilder(pobjDataAdapter)
```

```
pobjCommandBuilder.DeriveParameters(pobjCommand)
```

Be careful while using “DeriveParameters” method as it needs an extra trip to the Datastore which can be very inefficient.

(B) What's difference between "Optimistic" and "Pessimistic" locking ?

In pessimistic locking when user wants to update data it locks the record and till then no one can update data. Other user's can only view the data when there is pessimistic locking.

In optimistic locking multiple users can open the same record for updating, thus increase maximum concurrency. Record is only locked when updating the record. This is the most preferred way of locking practically. Now a days browser based application is very common and having pessimistic locking is not a practical solution.

(A) How many ways are there to implement locking in ADO.NET ?

Following are the ways to implement locking using ADO.NET :-

√ When we call "Update" method of DataAdapter it handles locking internally. If the DataSet values are not matching with current data in Database it raises concurrency exception error. We can easily trap this error using Try..Catch block and raise appropriate error message to the user.

√ Define a Datetime stamp field in the table. When actually you are firing the UPDATE SQL statements compare the current timestamp with one existing in the database. Below is a sample SQL which checks for timestamp before updating and any mismatch in timestamp it will not update the records. This is the best practice used by industries for locking.

Update table1 set field1=@test where LastTimeStamp=@CurrentTimeStamp

√ Check for original values stored in SQL SERVER and actual changed values. In stored procedure check before updating that the old data is same as the current. Example in the below shown SQL before updating field1 we check that is the old field1 value same. If not then some one else has updated and necessary action has to be taken.

Update table1 set field1=@test where field1 = @oldfield1value

Locking can be handled at ADO.NET side or at SQL SERVER side i.e. in stored procedures. For more details of how to implementing locking in SQL SERVER read "What are different locks in SQL SERVER ?" in SQL SERVER chapter.

Note:- This is one of the favorite questions of interviewer, so cram it... When I say cram it I do not mean it... I mean understand it. This book has tried to cover ADO.NET as much as possible, but indeterminist nature of ADO.NET interview questions makes it difficult to make full justice. But hope so that the above questions will make you quiet confident during interviews.

(A)How can we perform transactions in .NET?

The most common sequence of steps that would be performed while developing a transactional application is as follows:

- √ Open a database connection using the Open method of the connection object.
- √ Begin a transaction using the Begin Transaction method of the connection object. This method provides us with a transaction object that we will use later to commit or rollback the transaction. Note that changes caused by any queries executed before calling the Begin Transaction method will be committed to the database immediately after they execute. Set the Transaction property of the command object to the above mentioned transaction object.
- √ Execute the SQL commands using the command object. We may use one or more command objects for this purpose, as long as the Transaction property of all the objects is set to a valid transaction object.
- √ Commit or roll back the transaction using the Commit or Rollback method of the transaction object.
- √ Close the database connection.

(I)What is difference between Dataset. clone and Dataset. copy ?

Clone: - It only copies structure, does not copy data.

Copy: - Copies both structure and data.

(A)Can you explain the difference between an ADO.NET Dataset and an ADO Recordset?

There two main basic differences between recordset and dataset :-

-
- √ With dataset you can retrieve data from two databases like oracle and sql server and merge them in one dataset , with recordset this is not possible
 - √ All representation of Dataset is using XML while recordset uses COM.
 - √ Recordset can not be transmitted on HTTP while Dataset can be.

(A) Explain in detail the fundamental of connection pooling?

When a connection is opened first time a connection pool is created and is based on the exact match of the connection string given to create the connection object. Connection pooling only works if the connection string is the same. If the connection string is different, then a new connection will be opened, and connection pooling won't be used.

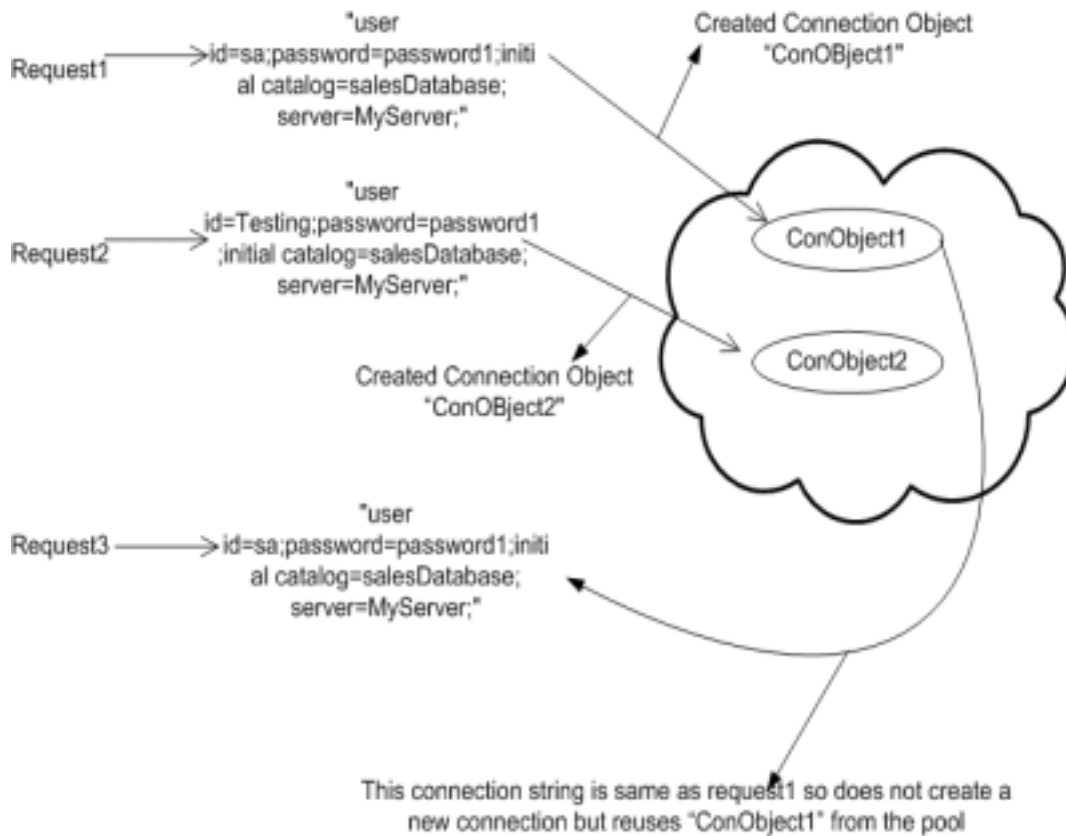

Figure 9.5 : - Connection Pooling action.

Lets try to explain the same pictorially. In the above figure you can see there are three requests "Request1", "Request2" and "Request3". "Request1" and "Request3" have same connection string so no new connection object is created for "Request3" as the connection string is same. They share the same object "ConObject1". But new object "ConObject2" is created for "Request2" as the connection string is different.

Note: - The difference between the connection string is that one has "User id=sa" and other has "User id=Testing".

(A)What is Maximum Pool Size in ADO.NET Connection String?

10 . SQL SERVER

Note :- This chapter is too small to cover SQL Server completely. I will suggest you to buy my SQL Server Interview Question book to gain full confidence during interview for this product.

(B) What is normalization? What are different types of normalization?

Note :- A regular .NET programmer working on projects often stumbles in this question, which is but obvious. Bad part is sometimes interviewer can take this as a very basic question to be answered and it can be a turning point for the interview. So let's cram it.

It is set of rules that have been established to aid in the design of tables that are meant to be connected through relationships. This set of rules is known as Normalization.

Benefits of normalizing your database will include:

- √ Avoiding repetitive entries
- √ Reducing required storage space
- √ Preventing the need to restructure existing tables to accommodate new data.
- √ Increased speed and flexibility of queries, sorts, and summaries.

Note :- During interview people are expect to answer maximum of three normal forms and that's what is expected practically. Actually you can normalize database to fifth normal form. But believe this book will answer three normal forms that will put you in decent shape during interview.

Following are the three normal forms :-

First Normal Form

For a table to be in first normal form, data must be broken up into the smallest units possible. In addition to breaking data up into the smallest meaningful values, tables in first normal form should not contain repetitions groups of fields.

Customer id	Customer Name	City1	City2	Unit Price	Qty	Total
3243244	Shivprasad koirala	xyz	PQR	1	12	12\$
3043244	Sanjana koirala	x cv	123	10	1	10\$

Figure :- 10.1 Repeating groups example

For in the above example city1 and city2 are repeating. In order that this table to be in First normal form you have to modify the table structure as follows. Also not that the Customer Name is now broken down to first name and last name (First normal form data should be broken down to smallest unit).

Customer id	First Name	Last Name	City	Unit Price	Qty	Total
3243244	Shivprasad	Koirala	xyz	1	12	12\$
3243244	Shivprasad	koirala	PQR	1	12	12\$
3043244	Sanjana	koirala	x cv	2	20	40\$
3043244	sanjana	Koirala	123	2	20	40\$

Figure :- 10.2 Customer table normalized to first normal form

Second Normal form

The second normal form states that each field in a multiple field primary key table must be directly related to the entire primary key. Or in other words, each non-key field should be a fact about all the fields in the primary key.

In the above table of customer, city is not linked to any primary field.

Customer id	First Name	Last Name	City	Unit Price	Qty	Total
3243244	Shivprasad	Koirala	xyz	1	12	12\$
3243244	Shivprasad	koirala	PQR	1	12	12\$
3043244	Sarjana	koirala	x cv	2	20	40\$
3043244	sarjana	Koirala	123	2	20	40\$

Figure :- 10.3 Normalized customer table.

City id	City
1	xyz
2	PQR
3	x cv
4	123

Figure :- 10.4 City is now shifted to a different master table.

That takes our database to a second normal form.

Third normal form

A non-key field should not depend on other Non-key field. The field "Total" is dependent on "Unit price" and "qty".

Customer id	First Name	Last Name	City	Unit Price	Qty
3243244	Shivprasad	Koirala	xyz	1	12
3243244	Shivprasad	koirala	PQR	1	12
3043244	Sarjana	koirala	x cv	2	20
3043244	sarjana	Koirala	123	2	20

Figure :- 10.5 Fill third normal form

So now the "Total" field is removed and is multiplication of Unit price * Qty.

Note :- Fourth and Fifth normal form is left as a home work to users.

(B)What is denormalization ?

Denormalization is the process of putting one fact in numerous places (its vice-versa of normalization). Only one valid reason exists for denormalizing a relational design - to enhance performance. The sacrifice to performance is that you increase redundancy in database.

(B) What is a candidate key ?

A table may have more than one combination of columns that could uniquely identify the rows in a table; each combination is a candidate key. During database design you can pick up one of the candidate keys to be the primary key. For example, in the supplier table supplierid and suppliername can be candidate key but you will only pick up supplierid as the primary key.

(B) What are the different types of joins? What is the difference between them ?

INNER JOIN

Inner join shows matches only when they exist in both tables. Example, in the below SQL there are two tables Customers and Orders and the inner join is made on Customers Customerid and Orders Customerid. So this SQL will only give you result with customers who have orders. If the customer does not have order it will not display that record.

```
SELECT Customers.*, Orders.* FROM Customers INNER JOIN Orders ON  
Customers.CustomerID =Orders.CustomerID
```

LEFT OUTER JOIN

Left join will display all records in left table of the SQL statement. In SQL below customers with or without orders will be displayed. Order data for customers without orders appears as NULL values. For example, you want to determine the amount ordered by each customer and you need to see who has not ordered anything as well. You can also see the LEFT OUTER JOIN as a mirror image of the RIGHT OUTER JOIN (Is covered in the next section) if you switch the side of each table.

```
SELECT Customers.*, Orders.* FROM Customers LEFT OUTER JOIN Orders ON  
Customers.CustomerID =Orders.CustomerID
```

RIGHT OUTER JOIN

Right join will display all records in right table of the SQL statement. In SQL below all orders with or without matching customer records will be displayed. Customer data for orders without customers appears as NULL values. For example, you want to determine if there are any orders in the data with undefined CustomerID values (say, after a conversion or something like it). You can also see the RIGHT OUTER JOIN as a mirror image of the LEFT OUTER JOIN if you switch the side of each table.

```
SELECT Customers.*, Orders.* FROM Customers RIGHT OUTER JOIN Orders  
ON Customers.CustomerID =Orders.CustomerID
```

(I)What are indexes? What is the difference between clustered and nonclustered indexes?

Indexes in SQL Server are similar to the indexes in books. They help SQL Server retrieve the data quickly.

There are clustered and nonclustered indexes. A clustered index is a special type of index that reorders the way in which records in the table are physically stored. Therefore table can have only one clustered index. The leaf nodes of a clustered index contain the data pages.

A nonclustered index is a special type of index in which the logical order of the index does not match the physical stored order of the rows on disk. The leaf node of a nonclustered index does not consist of the data pages. Instead, the leaf nodes contain index rows.

(A)How can you increase SQL performance ?

Following are tips which will increase your SQL performance :-

- √ Every index increases the time takes to perform INSERTS, UPDATES and DELETES, so the number of indexes should not be too much. Try to use maximum 4-5 indexes on one table, not more. If you have read-only table, then the number of indexes may be increased.

-
- √ Keep your indexes as narrow as possible. This reduces the size of the index and reduces the number of reads required to read the index.
 - √ Try to create indexes on columns that have integer values rather than character values.
 - √ If you create a composite (multi-column) index, the order of the columns in the key are very important. Try to order the columns in the key as to enhance selectivity, with the most selective columns to the leftmost of the key.
 - √ If you want to join several tables, try to create surrogate integer keys for this purpose and create indexes on their columns.
 - √ Create surrogate integer primary key (identity for example) if your table will not have many insert operations.
 - √ Clustered indexes are more preferable than nonclustered, if you need to select by a range of values or you need to sort results set with GROUP BY or ORDER BY.
 - √ If your application will be performing the same query over and over on the same table, consider creating a covering index on the table.
 - √ You can use the SQL Server Profiler Create Trace Wizard with "Identify Scans of Large Tables" trace to determine which tables in your database may need indexes. This trace will show which tables are being scanned by queries instead of using an index.

(A)What is the use of OLAP ?

OLAP is useful because it provides fast and interactive access to aggregated data and the ability to drill down to detail.

(A)What is a measure in OLAP ?

Measures are the key performance indicator that you want to evaluate. To determine which of the numbers in the data might be measures. A rule of thumb is: If a number makes sense when it is aggregated, then it is a measure.

(A)What are dimensions in OLAP ?

Dimensions are the categories of data analysis. For example, in a revenue report by month by sales region, the two dimensions needed are time and sales region. Typical dimensions include product, time, and region.

(A)What are levels in dimensions ?

Dimensions are arranged in hierarchical levels, with unique positions within each level. For example, a time dimension may have four levels, such as Year, Quarter, Month, and Day. Or the dimension might have only three levels, for example, Year, Week, and Day. The values within the levels are called members. For example, the years 2002 and 2003 are members of the level Year in the Time dimension.

(A)What are fact tables and dimension tables in OLAP ?

Twist :- Can you explain the star schema for OLAP ?

The dimensions and measures are physically represented by a star schema. Dimension tables revolve around fact table. A fact table contains a column for each measure as well as a column for each dimension. Each dimension column has a foreign-key relationship to the related dimension table, and the dimension columns taken together are the key to the fact table.

(A)What is DTS?

DTS is used to pull data from various sources into the star schema.

(A)What is fillfactor ?

Twist :- When does page split occurs ?

The 'fill factor' option specifies how full SQL Server will make each index page. When there is no free space to insert new row on the index page, SQL Server will create new index page and transfer some rows from the previous page to the new one. This operation is called page splits. You can reduce the number of page splits by setting the appropriate fill factor option to reserve free space on each index page. The fill factor is a value from 1 through 100 that specifies the percentage of the index page to be left empty. The default value for fill factor is 0. It is treated similarly to a fill factor value of 100, the difference in that SQL Server leaves some space within the upper level of the index tree for FILLFACTOR = 0. The fill factor percentage is used only at the time when the index is created. If the table contains read-only data (or data that very rarely changed), you can

set the 'fill factor' option to 100. When the table's data is modified very often, you can decrease the fill factor to 70% or whatever you think is best.

(A)What is RAID and how does it work ?

Redundant Array of Independent Disks (RAID) is a term used to describe the technique of improving data availability through the use of arrays of disks and various data-striping methodologies. Disk arrays are groups of disk drives that work together to achieve higher data-transfer and I/O rates than those provided by single large drives. An array is a set of multiple disk drives plus a specialized controller (an array controller) that keeps track of how data is distributed across the drives. Data for a particular file is written in segments to the different drives in the array rather than being written to a single drive.

For speed and reliability, it is better to have more disks. When these disks are arranged in certain patterns and are use a specific controller, they are called a Redundant Array of Inexpensive Disks (RAID) set. There are several numbers associated with RAID, but the most common are 1, 5 and 10.

RAID 1 works by duplicating the same writes on two hard drives. Let us assume you have two 20 Gigabyte drives. In RAID 1, data is written at the same time to both the drives. RAID1 is optimized for fast writes.

RAID 5 works by writing parts of data across all drives in the set (it requires at least three drives). If a drive failed, the entire set would be worthless. To combat this problem, one of the drives stores a "parity" bit. Think of a math problem, such as $3 + 7 = 10$. You can think of the drives as storing one of the numbers, and the 10 is the parity part. By removing any one of the numbers, you can get it back by referring to the other two, like this: $3 + X = 10$. Of course, losing more than one could be evil. RAID 5 is optimized for reads.

RAID 10 is a bit of a combination of both types. It doesn't store a parity bit, so it is faster, but it duplicates the data on two drives to be safe. You need at least four drives for RAID 10. This type of RAID is probably the best compromise for a database server.

Note :- It's difficult to cover complete aspect of RAID in this book. It's better to take some decent SQL SERVER book for in detail knowledge, but yes from interview aspect you can probably escape with this answer.

(B)What is the difference between DELETE TABLE and TRUNCATE TABLE commands?

Following are difference between them :-

- √ DELETE TABLE syntax logs the deletes thus make the delete operation slow. TRUNCATE table does not log any information but it logs information about deallocation of data page of the table so TRUNCATE table is faster as compared to delete table.
- √ DELETE table can have criteria while TRUNCATE can not.
- √ TRUNCATE table can not trigger.

Note :- Thanks to all the readers for pointing out my mistake for the above question in my first edition. I had mentioned that TRUNCATE table can not be rolled back while delete can be.

(B)If locking is not implemented what issues can occur ?

Following are the problems that occur if you do not implement locking properly in SQL SERVER.

Lost Updates

Lost updates occur if you let two transactions modify the same data at the same time, and the transaction that completes first is lost. You need to watch out for lost updates with the READ UNCOMMITTED isolation level. This isolation level disregards any type of locks, so two simultaneous data modifications are not aware of each other. Suppose that a customer has due of 2000\$ to be paid. He pays 1000\$ and again buys a product of 500\$. Lets say that these two transactions are now been entered from two different counters of the company. Now both the counter user starts making entry at the same time 10:00 AM. Actually speaking at 10:01 AM the customer should have $2000\$ - 1000\$ + 500 = 1500\$$ pending to be paid. But as said in lost updates the first transaction is not considered and the second transaction overrides it. So the final pending is $2000\$ + 500\$ = 2500\$$I hope the company does not loose the customer.

Non-Repeatable Read

Non-repeatable reads occur if a transaction is able to read the same row multiple times and gets a different value each time. Again, this problem is most likely to occur with the READ UNCOMMITTED isolation level. Because you let two transactions modify data at the same time, you can get some unexpected results. For instance, a customer wants to book flight, so the travel agent checks for the flights availability. Travel agent finds a seat and goes ahead to book the seat. While the travel agent is booking the seat, some other travel agent books the seat. When this travel agent goes to update the record, he gets error saying that "Seat is already booked". In short the travel agent gets different status at different times for the seat.

Dirty Reads

Dirty reads are a special case of non-repeatable read. This happens if you run a report while transactions are modifying the data that you're reporting on. For example there is a customer invoice report which runs on 1:00 AM in afternoon and after that all invoices are sent to the respective customer for payments. Let us say one of the customer has 1000\$ to be paid. Customer pays 1000\$ at 1:00 AM and at the same time report is run. Actually customer has no money pending but is still issued an invoice.

Phantom Reads

Phantom reads occur due to a transaction being able to read a row on the first read, but not being able to modify the same row due to another transaction deleting rows from the same table. Lets say you edit a record in the mean time somebody comes and deletes the record, you then go for updating the record which does not exist....Panicked.

Interestingly, the phantom reads can occur even with the default isolation level supported by SQL Server: READ COMMITTED. The only isolation level that doesn't allow phantoms is SERIALIZABLE, which ensures that each transaction is completely isolated from others. In other words, no one can acquire any type of locks on the affected row while it is being modified.

(B)What are different transaction levels in SQL SERVER?

Twist :- What are different types of locks in SQL SERVER ?

Transaction Isolation level decides how is one process isolated from other process. Using transaction levels you can implement locking in SQL SERVER.

There are four transaction levels in SQL SERVER :-

READ COMMITTED

The shared lock is held for the duration of the transaction, meaning that no other transactions can change the data at the same time. Other transactions can insert and modify data in the same table, however, as long as it is not locked by the first transaction.

READ UNCOMMITTED

No shared locks and no exclusive locks are honored. This is the least restrictive isolation level resulting in the best concurrency but the least data integrity.

REPEATABLE READ

This setting disallows dirty and non-repeatable reads. However, even though the locks are held on read data, new rows can still be inserted in the table, and will subsequently be interpreted by the transaction.

SERIALIZABLE

This is the most restrictive setting holding shared locks on the range of data. This setting does not allow the insertion of new rows in the range that is locked; therefore, no phantoms are allowed.

Following is the syntax for setting transaction level in SQL SERVER.

SET TRANSACTION ISOLATION LEVEL SERIALIZABLE

(I)What are the different locks in SQL SERVER ?

Depending on the transaction level six types of lock can be acquired on data :-

Intent

The intent lock shows the future intention of SQL Server's lock manager to acquire locks on a specific unit of data for a particular transaction. SQL Server uses intent locks to queue exclusive locks, thereby ensuring that these locks will be placed on the data elements in the order the transactions were initiated. Intent locks come in three flavors: intent shared (IS), intent exclusive (IX), and shared with intent exclusive (SIX).

IS locks indicate that the transaction will read some (but not all) resources in the table or page by placing shared locks.

IX locks indicate that the transaction will modify some (but not all) resources in the table or page by placing exclusive locks.

SIX locks indicates that the transaction will read all resources, and modify some (but not all) of them. This will be accomplished by placing the shared locks on the resources read and exclusive locks on the rows modified. Only one SIX lock is allowed per resource at one time; therefore, SIX locks prevent other connections from modifying any data in the resource (page or table), although they do allow reading the data in the same resource.

Shared

Shared locks (S) allow transactions to read data with SELECT statements. Other connections are allowed to read the data at the same time; however, no transactions are allowed to modify data until the shared locks are released.

Update

Update locks (U) are acquired just prior to modifying the data. If a transaction modifies a row, then the update lock is escalated to an exclusive lock; otherwise, it is converted to a shared lock. Only one transaction can acquire update locks to a resource at one time. Using update locks prevents multiple connections from having a shared lock that want to eventually modify a resource using an exclusive lock. Shared locks are compatible with other shared locks, but are not compatible with Update locks.

Exclusive

Exclusive locks (X) completely lock the resource from any type of access including reads. They are issued when data is being modified through INSERT, UPDATE and DELETE statements.

Schema

Schema modification locks (Sch-M) are acquired when data definition language statements, such as CREATE TABLE, CREATE INDEX, ALTER TABLE, and so on are being executed. Schema stability locks (Sch-S) are acquired when store procedures are being compiled.

Bulk Update

Bulk update locks (BU) are used when performing a bulk-copy of data into a table with TABLOCK hint. These locks improve performance while bulk copying data into a table; however, they reduce concurrency by effectively disabling any other connections to read or modify data in the table.

(I)Can we suggest locking hints to SQL SERVER ?

We can give locking hints that helps you over ride default decision made by SQL Server. For instance, you can specify the ROWLOCK hint with your UPDATE statement to convince SQL Server to lock each row affected by that data modification. Whether it's prudent to do so is another story; what will happen if your UPDATE affects 95% of rows in the affected table? If the table contains 1000 rows, then SQL Server will have to acquire 950 individual locks, which is likely to cost a lot more in terms of memory than acquiring a single table lock. So think twice before you bombard your code with ROWLOCKS.

(I)What is LOCK escalation?

Lock escalation is the process of converting of low level locks (like row locks, page locks) into higher level locks (like table locks). Every lock is a memory structure too many locks would mean, more memory being occupied by locks. To prevent this from happening, SQL Server escalates the many fine-grain locks to fewer coarse-grain locks. Lock escalation threshold was definable in SQL Server 6.5, but from SQL Server 7.0 onwards it's dynamically managed by SQL Server.

(B)What are the different ways of moving data between databases in SQL Server?

There are lots of option available; you have to choose your option depending upon your requirements. Some of the options you have are: BACKUP/RESTORE, detaching and

attaching databases, replication, DTS, BCP, logshipping, INSERT...SELECT, SELECT...INTO, creating INSERT scripts to generate data.

(I)What are advantages of SQL 2000 over SQI 7.0 ?

- √ User-Defined Functions: User-Defined Functions (UDFs) -- one or more Transact-SQL statements can be used to encapsulate code for reuse. User-defined functions cannot make a permanent change to the data or modify database tables. UDF can change only local objects for a UDF, such as local cursors or variables.
- √ Distributed Partitioned Views: Distributed partitioned views allow you to partition tables horizontally across multiple servers. So, you can scale out one database server to a group of database servers that cooperate to provide the same performance levels as a cluster of database servers. Due to distributed partitioned views, SQL Server 2000 now on the first place in the tpc-c tests.
- √ New Data Types: These include: bigint, an 8-byte integer type; sql_variant, a data type that allows the storage of data of different data types; and the table data type, which allows applications to store results temporarily for later use.
- √ INSTEAD OF and AFTER Triggers: There are INSTEAD OF and AFTER Triggers in SQL Server 2000. INSTEAD OF triggers are executed instead of the INSERT, UPDATE or DELETE triggering action. AFTER triggers are executed after the triggering action.
- √ Cascading Referential Integrity Constraints: There are new ON DELETE and ON UPDATE clauses in the REFERENCES clause of the CREATE TABLE and ALTER TABLE statements. The ON DELETE clause controls what actions are taken if you attempt to delete a row to which existing foreign keys point. The ON UPDATE clause defines the actions that are taken if you attempt to update a candidate key value to which existing foreign keys point.
- √ The ON DELETE and ON UPDATE clauses have two options:
 - NO ACTION :-NO ACTION specifies that the deletion/update fail with an error.
 - CASCADE :-CASCADE specifies that all the rows with foreign keys pointing to the deleted/updated row are also deleted and updated.

-
- √ 32 CPU and 64GB Memory Support: SQL Server 2000 Enterprise Edition running under Windows 2000 DataCenter can support up to 32 CPUs and up to 64GB of physical memory (RAM) on a computer.
 - √ XML Support: SQL Server 2000 can use XML to insert, update, and delete values in the database, and the database engine can return data as Extensible Markup Language (XML) documents

(B)What is the difference between a HAVING CLAUSE and a WHERE CLAUSE?

You can use Having Clause with the GROUP BY function in a query and WHERE Clause is applied to each row before they are part of the GROUP BY function in a query.

(B) What is the difference between UNION and UNION ALL SQL syntax ?

UNION SQL syntax is used to select information from two tables. But it selects only distinct records from both the table, while UNION ALL selects all records from both the tables.

Note :- Selected records should have same datatype or else the syntax will not work.

(I)How can you raise custom errors from stored procedure ?

The RAISERROR statement is used to produce an ad hoc error message or to retrieve a custom message that is stored in the sysmessages table. You can use this statement with the error handling code presented in the previous section to implement custom error messages in your applications. The syntax of the statement is shown here.

```
RAISERROR ( {msg_id |msg_str } {,severity ,state }  
[ ,argument [ ,...n ] ] )  
[ WITH option [ ,...n ] ]
```

A description of the components of the statement follows.

msg_id :-The ID for an error message, which is stored in the error column in sysmessages.

`msg_str` :-A custom message that is not contained in `sysmessages`.

`severity` :- The severity level associated with the error. The valid values are 0–25. Severity levels 0–18 can be used by any user, but 19–25 are only available to members of the fixed-server role `sysadmin`. When levels 19–25 are used, the `WITH LOG` option is required.

`state` A value that indicates the invocation state of the error. The valid values are 0–127. This value is not used by SQL Server.

Argument, . . .

One or more variables that are used to customize the message. For example, you could pass the current process ID (`@@SPID`) so it could be displayed in the message.

`WITH` option, . . .

The three values that can be used with this optional argument are described here.

`LOG` - Forces the error to log in the SQL Server error log and the NT application log.

`NOWAIT` - Sends the message immediately to the client.

`SETERROR` - Sets `@@ERROR` to the unique ID for the message or 50,000.

The number of options available for the statement makes it seem complicated, but it is actually easy to use. The following shows how to create an ad hoc message with a severity of 10 and a state of 1.

```
RAISERROR ('An error occurred updating the NonFatal table',10,1)
```

```
--Results--
```

```
An error occured updating the NonFatal table
```

The statement does not have to be used in conjunction with any other code, but for our purposes it will be used with the error handling code presented earlier. The following alters the `ps_NonFatal_INSERT` procedure to use `RAISERROR`.

```
USE tempdb
```

```
go
```

```
ALTER PROCEDURE ps_NonFatal_INSERT
```

```
@Column2 int =NULL
```

```
AS
```

```
DECLARE @ErrorMsgID int
```

```
INSERT NonFatal VALUES (@Column2)
```

```
SET @ErrorMsgID =@@ERROR
```

```
IF @ErrorMsgID <>0
```

```
BEGIN
```

```
    RAISERROR ('An error occured updating the NonFatal table',10,1)
```

```
END
```

When an error-producing call is made to the procedure, the custom message is passed to the client. The following shows the output generated by Query Analyzer.

(I) What is ACID fundamental? What are transactions in SQL SERVER ?

A transaction is a sequence of operations performed as a single logical unit of work. A logical unit of work must exhibit four properties, called the ACID (Atomicity, Consistency, Isolation, and Durability) properties, to qualify as a transaction:

Atomicity

- √ A transaction must be an atomic unit of work; either all of its data modifications are performed or none of them is performed.

Consistency

- √ When completed, a transaction must leave all data in a consistent state. In a relational database, all rules must be applied to the transaction's modifications to maintain all data integrity. All internal data structures, such as B-tree indexes or doubly-linked lists, must be correct at the end of the transaction.

Isolation

- √ Modifications made by concurrent transactions must be isolated from the modifications made by any other concurrent transactions. A transaction either see data in the state it was before another concurrent transaction modified it, or it sees the data after the second transaction has completed, but it does not see an intermediate state. This is referred to as serializability because it results in the ability to reload the starting data and replay a series of transactions to end up with the data in the same state it was in after the original transactions were performed.

Durability

- √ After a transaction has completed, its effects are permanently in place in the system. The modifications persist even in the event of a system failure.

(A) What is DBCC?

DBCC (Database Consistency Checker Commands) is used to check logical and physical consistency of database structure. DBCC statements can fix and detect problems. They are grouped in to four categories :-

- √ Maintenance commands like DBCC DBREINDEX , DBCC DBREPAR etc , they are mainly used for maintenance tasks in SQL SERVER.
- √ Miscellaneous commands like DBCC ROWLOCK , DBCC TRACE0 etc , they are mainly used for enabling row-level locking or removing DLL from memory.
- √ Status Commands like DBCC OPENTRAN , DBCC SHOWCONTIG etc , they are mainly used for checking status of the database.
- √ Validation Commands like DBCC CHECKALLOC, DBCC CHECKCATALOG etc , they perform validation operations on database.

Note :- Check MSDN for list of all DBCC commands, it is very much possible specially during DBA interviews they can ask in depth individual commands.

Below is a sample screen in which DBCC SHOWCONTIG command is run. DBCC SHOWCONTIG is used to display fragmentation information for the data and indexes of the specified table. In the sample screen “Customer” table is checked for fragmentation

information. If you look at the figure “Scan density” is 100 if everything is contiguous in this image it is 95.36% which is decent percentage. So such type of useful information can be collected by DBCC command and database performance and maintenance can be improved.

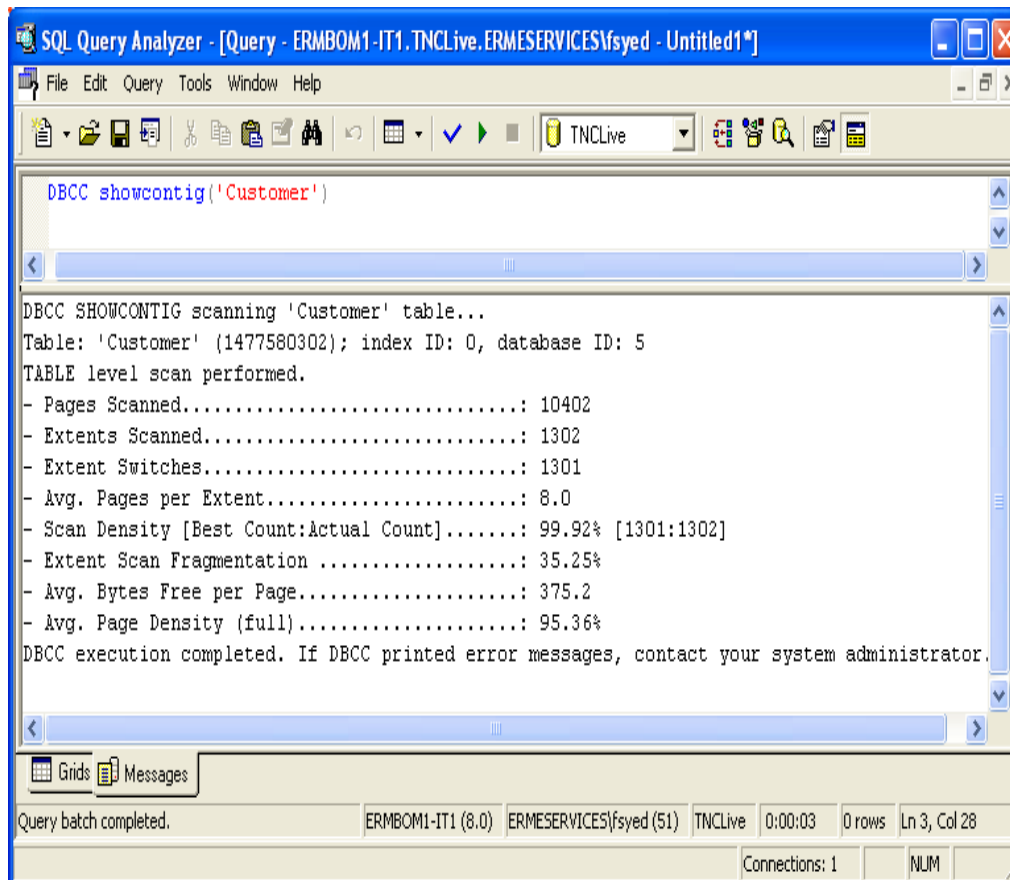

Figure :- 10.6 DBCC SHOWCONTIG command in action.

(A) What is the purpose of Replication ?

Replication is way of keeping data synchronized in multiple databases. SQL server replication has two important aspects publisher and subscriber.

Publisher

Database server that makes data available for replication is called as Publisher.

Subscriber

Database Servers that get data from the publishers is called as Subscribers.

(A) What are the different types of replication supported by SQL SERVER ?

There are three types of replication supported by SQL SERVER:-

Snapshot Replication.

Snapshot Replication takes snapshot of one database and moves it to the other database. After initial load data can be refreshed periodically. The only disadvantage of this type of replication is that all data has to be copied each time the table is refreshed.

Transactional Replication

In transactional replication data is copied first time as in snapshot replication, but later only the transactions are synchronized rather than replicating the whole database. You can either specify to run continuously or on periodic basis.

Merge Replication.

Merge replication combines data from multiple sources into a single central database. Again as usual the initial load is like snapshot but later it allows change of data both on subscriber and publisher, later when they come on-line it detects and combines them and updates accordingly.

(I) What is BCP utility in SQL SERVER ?

BCP (Bulk Copy Program) is a command line utility by which you can import and export large amounts of data in and out of SQL SERVER database.

Below is a sample which shows BCP in action.

```
C:\WINDOWS\System32\cmd.exe
C:\>bcp interview.dbo.customer out c:\x.bcp
Password:

Enter the file storage type of field Custid [int]:
Enter prefix-length of field Custid [0]:
Enter field terminator [none]:

Enter the file storage type of field CustName [nvarchar]:
Enter prefix-length of field CustName [2]:
Enter field terminator [none]:

Enter the file storage type of field CustSurname [nvarchar]:
Enter prefix-length of field CustSurname [2]:
Enter field terminator [none]:

Do you want to save this format information in a file? [Y/n]
Host filename [bcp.fmt]:

Starting copy...

4 rows copied.
Network packet size (bytes): 4096
Clock Time (ms.): total 16

C:\>
```

Figure :- 10.7 Export BCP utility in action

```
C:\WINDOWS\System32\cmd.exe
C:\>bcp interview.dbo.customer1 in c:\x.bcp
Password:
Enter the file storage type of field Custid [int]:
Enter prefix-length of field Custid [0]:
Enter field terminator [none]:
Enter the file storage type of field CustName [nvarchar]:
Enter prefix-length of field CustName [2]:
Enter field terminator [none]:
Enter the file storage type of field CustSurname [nvarchar]:
Enter prefix-length of field CustSurname [2]:
Enter field terminator [none]:
Do you want to save this format information in a file? [Y/n] y
Host filename [bcp.fmt]:
Starting copy...
4 rows copied.
Network packet size (bytes): 4096
Clock Time (ms.): total      171
C:\>
```

Figure :- 10.8 Import BCP utility in action

(I)What are the different types of triggers in SQL SERVER 2000 ?

There are two types of triggers :-

- √ INSTEAD OF triggers

INSTEAD OF triggers fire in place of the triggering action. For example, if an INSTEAD OF UPDATE trigger exists on the Sales table and an UPDATE statement is executed against the Salestable, the UPDATE statement will not change a row in the sales table. Instead, the UPDATE statement causes the INSTEAD OF UPDATE trigger to be executed, which may or may not modify data in the Sales table.

√ AFTER triggers

AFTER triggers execute following the SQL action, such as an insert, update, or delete. This is the traditional trigger which existed in SQL SERVER.

INSTEAD OF triggers gets executed automatically before the Primary Key and the Foreign Key constraints are checked, whereas the traditional AFTER triggers gets executed after these constraints are checked.

Unlike AFTER triggers, INSTEAD OF triggers can be created on views.

(A)If we have multiple AFTER Triggers on table how can we define the sequence of the triggers ?

If a table has multiple AFTER triggers, then you can specify which trigger should be executed first and which trigger should be executed last using the stored procedure sp_settriggerorder. All the other triggers are in an undefined order which you cannot control.

(A)What is SQL injection ?

It is a Form of attack on a database-driven Web site in which the attacker executes unauthorized SQL commands by taking advantage of insecure code on a system connected to the Internet, bypassing the firewall. SQL injection attacks are used to steal information from a database from which the data would normally not be available and/or to gain access to an organization's host computers through the computer that is hosting the database.

SQL injection attacks typically are easy to avoid by ensuring that a system has strong input validation.

As name suggest we inject SQL which can be relatively dangerous for the database. Example this is a simple SQL

```
SELECT email, passwd, login_id, full_name
FROM members
WHERE email = 'x'
```

Now somebody does not put "x" as the input but puts "x ; DROP TABLE members;". So the actual SQL which will execute is :-

```
SELECT email, passwd, login_id, full_name
FROM members
WHERE email = 'x' ; DROP TABLE members;
```

Think what will happen to your database.

What is the difference between Stored Procedure (SP) and User Defined Function (UDF)?

Following are some major differences between a stored procedure and user defined functions:-

- √ UDF can be executed using the “SELECT” clause while SP’s can not be.
- √ UDF can not be used in XML FOR clause but SP’s can be used.
- √ UDF does not return output parameters while SP’s return output parameters.
- √ If there is an error in UDF its stops executing. But in SP’s it just ignores the error and moves to the next statement.
- √ UDF can not make permanent changes to server environments while SP’s can change some of the server environment.

Note :- SQL Server product is equivalently important from interview point of view. Below are questions taken from my second book “SQL Server Interview questions”. If you are interested in buying the book mail bpb@bol.net.in / bpb@vsnl.com or call the nearest BPB book stall for my book. For shop phone numbers you can either see the back or front page of the book.

Database Concepts

What is database or database management systems (DBMS)?

What is the difference between DBMS and RDBMS ?

What are CODD rules?

Is access database a RDBMS?

What is the main difference between ACCESS and SQL SERVER?

What is the difference between MSDE and SQL SERVER 2000?

What is SQL SERVER Express 2005 Edition?

What is SQL Server 2000 Workload Governor?

What is the difference between SQL SERVER 2000 and 2005?

What are E-R diagrams?

How many types of relationship exist in database designing?

Can you explain Fourth Normal Form?

Can you explain Fifth Normal Form?

What's the difference between Fourth and Fifth normal form?

Have you heard about sixth normal form?

What is Extent and Page?

What are the different sections in Page?

What are page splits?

In which files does actually SQL Server store data?

What is Collation in SQL Server?

Can we have a different collation for database and table?

SQL

Revisiting basic syntax of SQL?

What are "GRANT" and "REVOKE" statements?

What is Cascade and Restrict in DROP table SQL?

How to import table using "INSERT" statement?

What is a DDL, DML and DCL concept in RDBMS world?

What are different types of joins in SQL?

What is "CROSS JOIN"?

Who will you select the first record in a given set of rows?

How do you sort in SQL?

How do you select unique rows using SQL?

Can you name some aggregate function is SQL Server?

What is the default “SORT” order for a SQL?

What is a self-join?

What’s the difference between DELETE and TRUNCATE ?

Select addresses which are between ‘1/1/2004’ and ‘1/4/2004’?

What are Wildcard operators in SQL Server?

What’s the difference between “UNION” and “UNION ALL” ?

What are cursors and in which situations you will use them?

What are the steps to create a cursor?

What are the different Cursor Types?

What are “Global” and “Local” cursors?

What is “Group by” clause?

What is ROLLUP?

What is CUBE?

What is the difference between “HAVING” and “WHERE” clause?

What is “COMPUTE” clause in SQL?

What is “WITH TIES” clause in SQL?

What does “SET ROWCOUNT” syntax achieves?

What is a Sub-Query?

What is “Correlated Subqueries”?

What is “ALL” and “ANY” operator?

What is a “CASE” statement in SQL?

What does COLLATE Keyword in SQL signify?

What is CTE (Common Table Expression)?

Why should you use CTE rather than simple views?

What is TRY/CATCH block in T-SQL?

What is PIVOT feature in SQL Server?

What is UNPIVOT?

What are RANKING functions?

What is ROW_NUMBER()?

What is RANK() ?

What is DENSE_RANK()?

What is NTILE()?

What is SQL injection ?

.NET Integration

What are steps to load a .NET code in SQL SERVER 2005?

How can we drop an assembly from SQL SERVER?

Are changes made to assembly updated automatically in database?

Why do we need to drop assembly for updating changes?

How to see assemblies loaded in SQL Server?

I want to see which files are linked with which assemblies?

Does .NET CLR and SQL SERVER run in different process?

Does .NET controls SQL SERVER or is it vice-versa?

Is SQLCLR configured by default?

How to configure CLR for SQL SERVER?

Is .NET feature loaded by default in SQL Server?

How does SQL Server control .NET run-time?

What's a "SAND BOX" in SQL Server 2005?

What is an application domain?

How are .NET Appdomain allocated in SQL SERVER 2005?

What is Syntax for creating a new assembly in SQL Server 2005?

Does Assemblies loaded in database needs actual .NET DLL?

You have an assembly which is dependent on other assemblies, will SQL Server load the dependent assemblies?

Does SQL Server handle unmanaged resources?

What is Multi-tasking?

What is Multi-threading?

What is a Thread ?

Can we have multiple threads in one App domain?

What is Non-preemptive threading?

What is pre-emptive threading?

Can you explain threading model in SQL Server?

How does .NET and SQL Server thread work?

How is the exception in SQLCLR code handled?

Are all .NET libraries allowed in SQL Server?

What is "Hostprotectionattribute" in SQL Server 2005?

How many types of permission level are there for an assembly?

In order that an assembly gets loaded in SQL Server what type of checks are done?

Can you name system tables for .NET assemblies?

Are two version of same assembly allowed in SQL Server?

How are changes made in assembly replicated?

Is it a good practice to drop a assembly for changes?

In one of the projects following steps where done, will it work?

What does Alter assembly with unchecked data signify?

How do I drop an assembly?

Can we create SQLCLR using .NET framework 1.0?

While creating .NET UDF what checks should be done?

How do you define a function from the .NET assembly?

Can you compare between T-SQL and SQLCLR?

With respect to .NET is SQL SERVER case sensitive?

Does case sensitive rule apply for VB.NET?

Can nested classes be accessed in T-SQL?

Can we have SQLCLR procedure input as array?

Can object datatype be used in SQLCLR?

How is precision handled for decimal datatypes in .NET?

How do we define INPUT and OUTPUT parameters in SQLCLR?

Is it good to use .NET datatypes in SQLCLR?

How to move values from SQL to .NET datatypes?

What is System.Data.SqlServer?

What is SQLContext?

Can you explain essential steps to deploy SQLCLR?

How to create function in SQL Server using .NET?

How do we create trigger using .NET?

How to create User Define Functions using .NET?

How to create aggregates using .NET?

What is Asynchronous support in ADO.NET?

What is MARS support in ADO.NET?

What is SQLbulkcopy object in ADO.NET?

How to select range of rows using ADO.NET?

What are the different types of triggers in SQL SERVER 2000 ?

If we have multiple AFTER Triggers on table how can we define the sequence of the triggers ?

How can you raise custom errors from stored procedure ?

ADO.NET

Which are namespaces for ADO.NET?

Can you give a overview of ADO.NET architecture?

What are the two fundamental objects in ADO.NET?

What is difference between dataset and datareader?

What are major difference between classic ADO and ADO.NET?

What is the use of connection object?

What are the methods provided by the command object?

What is the use of "Dataadapter"?

What are basic methods of "Dataadapter"?

What is Dataset object?

What are the various objects in Dataset?

How can we connect to Microsoft Access, FoxPro, Oracle etc?

What's the namespace to connect to SQL Server?

How do we use stored procedure in ADO.NET?

How can we force the connection object to close?

I want to force the datareader to return only schema?

Can we optimize command object when there is only one row?

Which is the best place to store connectionstring?

What are steps involved to fill a dataset?

What are the methods provided by the dataset for XML?

How can we save all data from dataset?

How can we check for changes made to dataset?

How can we add/remove rows in “DataTable” object of “DataSet”?

What’s basic use of “DataView”?

What is the difference between “DataSet” and “DataReader”?

How can we load multiple tables in a DataSet?

How can we add relations between table in a DataSet?

What’s the use of CommandBuilder?

What is the difference between “Optimistic” and “Pessimistic” locking?

How many ways are there to implement locking in ADO.NET?

How can we perform transactions in .NET?

What is the difference between Dataset. clone and Dataset. copy?

What is the difference between Dataset and ADO Recordset?

Notification Services

What are notification services?

What are basic components of Notification services?

Can you explain architecture of Notification Services?

Which are the two XML files needed for notification services?

What is Nscontrols command?

What are the situations you will use “Notification” Services?

Service Broker

What do we need Queues?

What is “Asynchronous” communication?

What is SQL Server Service broker?

What are the essential components of SQL Server Service broker?

What is the main purpose of having Conversation Group?

How to implement Service Broker?

How do we encrypt data between Dialogs?

XML Integration

What is XML?

What is the version information in XML?

What is ROOT element in XML?

If XML does not have closing tag will it work?

Is XML case sensitive?

What’s the difference between XML and HTML?

Is XML meant to replace HTML?

Can you explain why your project needed XML?

What is DTD (Document Type definition)?

What is well formed XML?

What is a valid XML?

What is CDATA section in XML?

What is CSS?

What is XSL?

What is Element and attributes in XML?

Can we define a column as XML?

How do we specify the XML data type as typed or untyped?

How can we create the XSD schema?

How do I insert in to a table which has XSD schema attached to it?

What is maximum size for XML datatype?

What is Xquery?

What are XML indexes?

What are secondary XML indexes?

What is FOR XML in SQL Server?

Can I use FOR XML to generate SCHEMA of a table? How?

What is the OPENXML statement in SQL Server?

I have huge XML file which we want to load in database?

How to call stored procedure using HTTP SOAP?

What is XMLA?

Data Warehousing/Data Mining

What is "Data Warehousing"?

What are Data Marts?

What are Fact tables and Dimension Tables?

What is Snow Flake Schema design in database?

What is ETL process in Data warehousing?

How can we do ETL process in SQL Server?

What is “Data mining”?

Compare “Data mining” and “Data Warehousing”?

What is BCP?

How can we import and export using BCP utility?

During BCP we need to change the field position or eliminate some fields

how can we achieve this?

What is Bulk Insert?

What is DTS?

Can you brief about the Data warehouse project you worked on?

What is an OLTP (Online Transaction Processing) System?

What is an OLAP (On-line Analytical processing) system?

What is Conceptual, Logical and Physical model?

What is Data purging?

What is Analysis Services?

What are CUBES?

What are the primary ways to store data in OLAP?

What is META DATA information in Data warehousing projects?

What is multi-dimensional analysis?

What is MDX?

How did you plan your Data ware house project?

What are different deliverables according to phases?

Can you explain how analysis service works?

What are the different problems that “Data mining” can solve?

What are different stages of “Data mining”?

What is Discrete and Continuous data in Data mining world?

What is MODEL is Data mining world?

How are models actually derived?

What is a Decision Tree Algorithm?

Can decision tree be implemented using SQL?

What is Naïve Bayes Algorithm?

Explain clustering algorithm?

Explain in detail Neural Networks?

What is Back propagation in Neural Networks?

What is Time Series algorithm in data mining?

Explain Association algorithm in Data mining?

What is Sequence clustering algorithm?

What are algorithms provided by Microsoft in SQL Server?

How does data mining and data warehousing work together?

What is XMLA?

What is Discover and Execute in XMLA?

Integration Services/DTS

What is Integration Services import / export wizard?

What are prime components in Integration Services?

How can we develop a DTS project in Integration Services?

Replication

What is the best way to update data between SQL Servers?
What are the scenarios you will need multiple databases with schema?
How will you plan your replication?
What are publisher, distributor and subscriber in “Replication”?
What is “Push” and “Pull” subscription?
Can a publication support push and pull at one time?
What are the different models / types of replication?
What is Snapshot replication?
What are the advantages and disadvantages of using Snapshot replication?
What type of data will qualify for “Snapshot replication”?
What’s the actual location where the distributor runs?
Can you explain in detail how exactly “Snapshot Replication” works?
What is merge replication?
How does merge replication works?
What are advantages and disadvantages of Merge replication?
What is conflict resolution in Merge replication?
What is a transactional replication?
Can you explain in detail how transactional replication works?
What are data type concerns during replications?

Reporting Services

Can you explain how can we make a simple report in reporting services?
How do I specify stored procedures in Reporting Services?

What is the architecture for “Reporting Services “?

Database Optimization

What are indexes?

What are B-Trees?

I have a table which has lot of inserts, is it a good database design to create indexes on that table?

What are “Table Scan’s” and “Index Scan’s”?

What are the two types of indexes and explain them in detail?

What is “FillFactor” concept in indexes?

What is the best value for “FillFactor”?

What are “Index statistics”?

How can we see statistics of an index?

How do you reorganize your index, once you find the problem?

What is Fragmentation?

How can we measure Fragmentation?

How can we remove the Fragmented spaces?

What are the criteria you will look into while selecting an index?

What is “Index Tuning Wizard”?

What is an Execution plan?

How do you see the SQL plan in textual format?

What is nested join, hash join and merge join in SQL Query plan?

What joins are good in what situations?

What is RAID and how does it work ?

Transaction and Locks

What is a “Database Transactions “?

What is ACID?

What is “Begin Trans”, “Commit Tran”, “Rollback Tran” and “Save Tran”?

What are “Checkpoint’s” in SQL Server?

What are “Implicit Transactions”?

Is it good to use “Implicit Transactions”?

What is Concurrency?

How can we solve concurrency problems?

What kind of problems occurs if we do not implement proper locking strategy?

What are “Dirty reads”?

What are “Unrepeatable reads”?

What are “Phantom rows”?

What are “Lost Updates”?

What are different levels of granularity of locking resources?

What are different types of Locks in SQL Server?

What are different Isolation levels in SQL Server?

What are different types of Isolation levels in SQL Server?

If you are using COM+ what “Isolation” level is set by default?

What are “Lock” hints?

What is a “Deadlock” ?

What are the steps you can take to avoid “Deadlocks” ?

How can I know what locks are running on which resource?

11 . UML

(B) What is UML?

The Unified Modeling Language (UML) is a graphical language for visualizing, specifying, constructing, and documenting the artifacts of a software-intensive system. UML provides blue prints for business process, System function, programming language statements, database schemas and reusable components.

(I) How many types of diagrams are there in UML ?

Twist :- Explain in short all types of diagrams in UML ?

There are nine types of diagrams in UML :-

Use case diagram:

They describe "WHAT" of a system rather than "HOW" the system does it. They are used to identify the primary elements and processes that form the system. The primary elements are termed as "actors" and the processes are called "use cases". Use Case diagrams shows "actors" and their "roles".

Class diagram:

From the use case diagram we can now go to detail design of system, for which the primary step is class diagram. The best way to identify classes is to consider all "NOUNS" in use cases as classes, "VERBS" as methods of classes, relation between actors can then be used to define relation between classes. The relationship or association between the classes can be either an "is-a" or "has-a" relationship which can easily be identified from use cases.

Object diagram:

An object is an instance of a class. Object diagram captures the state of classes in the system and their relationships or associations at a specific point of time.

State diagram:

A state diagram, as the name suggests, represents the different states that objects in the system undergo during their life cycle. Object change in response to certain simulation so

this simulation effect is captured in state diagram. So basically it has a initial state and final state and events that happen in between them. Whenever you think that some simulations are complicated you can go for this diagram.

Sequence diagram:

Sequence diagrams can be used to explore the logic of a complex operation, function, or procedure. They are called sequence diagrams because sequential nature is shown via ordering of messages. First message starts at the top and the last message ends at bottom. The important aspect of a sequence diagram is that it is time-ordered. This means that the exact sequence of the interactions between the objects is represented step by step. Different objects in the sequence diagram interact with each other by passing "messages".

Collaboration diagram:

A collaboration diagram groups together the interactions between different objects to fulfill a common purpose.

Activity diagram:

Activity diagram is typically used for business process modeling, for modeling the logic captured by a single use case, or for visualizing the detailed logic of a business rule. Complicated process flows in the system are captured in the activity diagram. Similar to a state diagram, an activity diagram also consists of activities, actions, transitions, initial and final states, and guard conditions. But difference is state diagrams are in context of simulation while activity gives detail view of business logic.

Deployment diagram:

Deployment diagrams show the hardware for your system, the software that is installed on that hardware, and the middleware used to connect the disparate machines to one another. It shows how the hardware and software work together to run a system. In one line its shows the deployment view of the system.

Component diagram:

The component diagram represents the high-level parts that make up the system. From .NET angle point of view they form the "NAMESPACES". This diagram depicts, at a

high level, what components form part of the system and how they are interrelated. Its shows the logical grouping of classes or group of other components.

Note :- The best way to remember all the blocks of UML is “Serve cool SOUP during church ceremony” that covers State chart, Class diagrams, Sequence diagram, Object diagram, Use Case diagram, Package diagram, Deployment diagram, Collaboration diagram, Component diagram.

(B) What are advantages of using UML?

Twist: - What is Modeling and why UML ?

As the name suggest UNIFIED MODELING LANGUAGE. Modelling has been around for years, not only in software field but also in other trades like civil, mechanical etc. Example in civil engineering drawing the main architecture built of diagram is a model by itself. Modelling makes complex and huge system to break up in to simple and discrete pieces that can be individually understood. Example simple flowchart drawing is modeling.

There are two main advantages of modeling:-

- √ **Readability:** - Representing your whole architecture in flowchart, class diagrams, ER diagrams etc makes your project more readable. Especially when programmer's change jobs handover becomes easier. More the project is not readable more the dependencies.
- √ **Reusability:** - After the system is more readable and broken down to pieces, it becomes easier to identify redundant and similar modules. Thus increasing reusability.

So why UML? Well different languages have different ways of coding and syntaxes. In order to bring all languages in one roof UML is in to picture. As the term comes in UNIFIED, it unifies all disparate languages in one roof so that can be understood by people who are working on some other platforms.

(A)What is the sequence of UML diagrams in project?

Twist: - How did you implement UML in your project?

First let me say some fact about this question, you can not implement all the nine diagrams given by UML in one project; you can but can be very rare scenario. The way UML is implemented in project varies from project to project and company to company.

Second very important point to remember is normally all diagrams are not implemented in project, but some basic diagrams are important to have in order that project is readable. When we talk about projects every project have phases example (Requirements phase, design phase, coding phase etc). As every phase of the software cycle proceeds these diagrams come in picture. Some diagrams span across multiple phases.

Note: - If you want to have a detail about software life cycle look out for chapter “Project Management”.

Normally following are different basic phases:-

Requirement phase (Use Case Diagrams, Activity diagrams)

Requirement phase is the phase where you normally gather requirement and Use Cases are the best things to make explanation of the system. In requirement phase you can further make complicated Use Cases more simple and easy to understand by using activity diagrams, but I do not see it as must in every project. If the Use cases are really complicated go for a Activity diagram. Example CRUD (creates, read, update and delete) operation use cases have no significance for making activity diagrams. So in short the outcome UML documents from requirement phase will be Use Case and Activity diagram documents (Activity diagram documents will only be there if there are complicated Use Cases to be simplified).

Just a small Twist: - Do I need all UML diagrams in a project?

Note: - This question is specially asked to know have you actually used UML. I have seen many guys trying to give some jack of all answers saying “YES”. Beware it is a trap.

Not all diagrams are needed in project example: - Activity diagrams will only be needed when you want some simplified look of a complicated use case.

Design phase (Class diagrams, object diagrams, Component diagrams, Collaboration diagrams, Deployment diagrams, Sequence diagrams)

Design phase is the phase where you design your technical architecture of your project. Now again in this you do not use all UML documents of a project.

But the next document after the Use Case document will be the Component diagram. Component diagrams form a high level classification of the system. So after “Use Cases” just try to come out with a high level classification / grouping of related functionalities.

This should be compulsory diagram as outcome of this document will form “NAMESPACES” structure of .NET project.

Ok now once your high level grouping is done you can go ahead with class diagrams. Especially from Use Case you get the “NOUNS” and “VERBS” which can form the class name and the method name respectively. From my point of view class diagrams should be compulsory in projects.

Object diagrams are not compulsory it depends on how complicated your project. Object diagrams shows the relation between instances of class at runtime. In short it captures the state and relation of classes at any given moment of time. Example you have class which creates objects of different classes, its like a factory. In class diagram you will only show that it as a simple class with a method called as “CreateObject”. But in object diagrams actually you will show the types of instances create from that object.

Collaboration diagrams mainly depict interaction between object to depict some purpose. I find this diagram to be more useful than Object diagrams as they are addressed for some purpose example “Login Process” which will use “Login object”, “User Object” etc to fulfill the login purpose. So if you find the process very complicated go for this diagram. I see as a thumb rule if there is an activity diagram which show some serious complicated scenarios. I will like to go for this diagram in order to simplify the explanation.

State chart diagram is again created if your project requires it. If your project has some complicated start and end states to show then this diagram is most useful. Recently I was making a call center project where the agent phone pickup and hang state has to be depicted. So my first state was when agent picks up the phone and the final stage was when agent hangs the phone, in between process was very complicated, which can only be shown by using state chart diagrams.

Sequence diagrams are needed if some sequence is complicated. Do not confuse sequence diagrams with Activity diagram, Activity diagrams map to a Use Case while sequence diagrams show object interaction in sequence.

Deployment diagrams are again not a compulsory requirement. It will show the hardware and software deployment of your system. If you really have leisure in your project go for it or if you want to make the client smile seeing some diagrams.

Implementation phase / Coding phase (Class diagrams for reverse

engineering, Other diagrams for validity check)

In this phase mostly class diagrams are re-engineered with the source code. But other diagrams are also present for validity check example state chart diagrams will be used in case to check that the both activity between those states follow the proper logic. If some things have to be changed then again there is iteration backward to the Requirement phase.

Testing phase

This phase mostly goes for the testing department. I am not talking about preparing UTP plans but SITP plans. Where the testing department will look at all diagrams to prepare a test plan and execute it. Example it will see the Use Case document to see the business rules, it will see the activity diagram and sequence diagrams to see the proper flow of modules. If some things are not proper there is iteration back to the Design phase.

Roll out and close over phases.

All document just to re-check that things are proper, example all modules deployed according to the deployment diagrams, are all business rules in Use Cases satisfied.

Let us revise the following points:-

- √ Not all diagrams are compulsory.
- √ The minimum diagrams according to software life cycle phases are :-
 - Requirement phase: - Use Case Diagrams
 - Design Phase: - Component diagrams, Class diagrams
 - Implementation phase: - All diagrams derived from pervious phases specially class diagram for reverse engineering.
 - Testing phase: - All diagrams derived from requirement and design phases for verification and preparing test plans.
 - Roll out and close over phase: - All document derived from Design phase and requirement phases.

Below is a sample figure which shows all the documents in relevant phases.

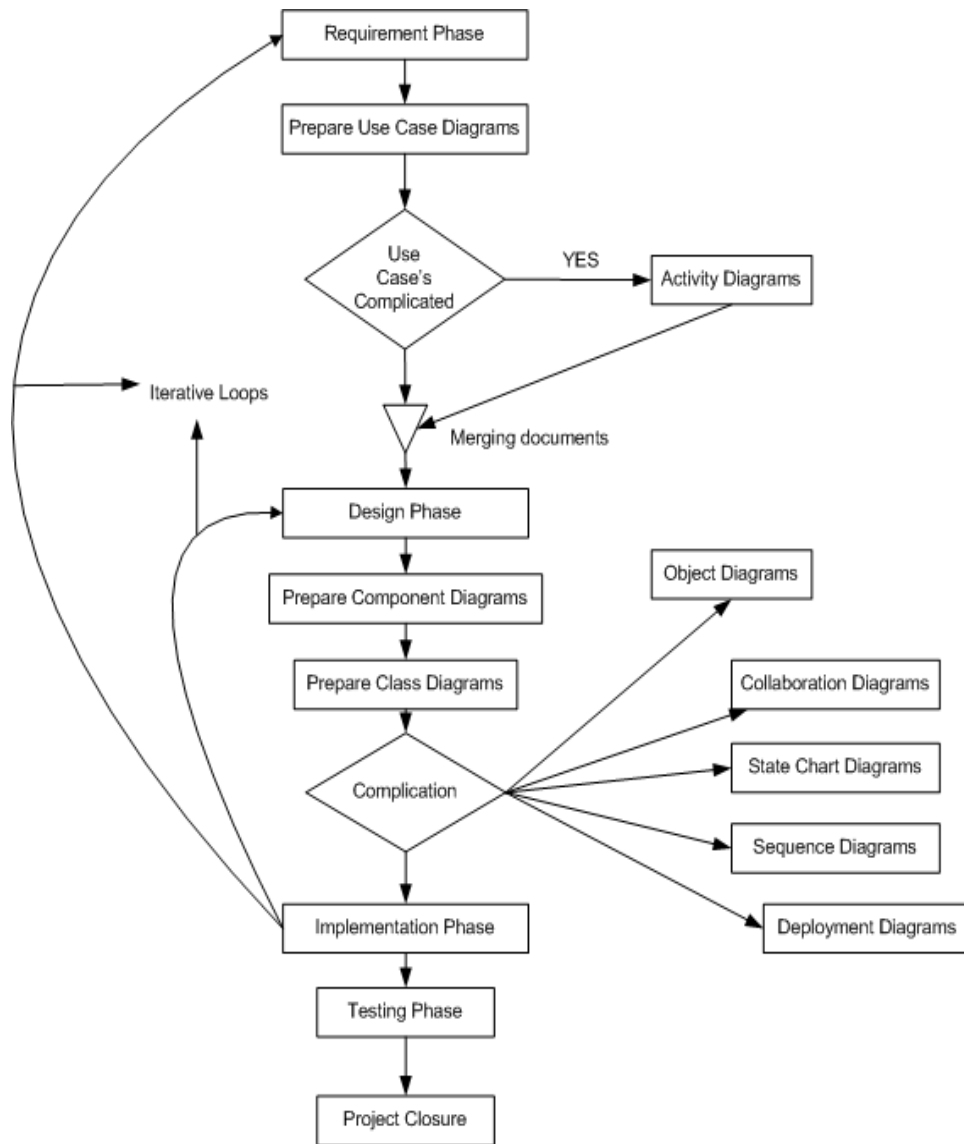

Figure :-11.1 Phase mapping with UML documents

Note:- This book will now attempt to describe every element of a UML diagram. But it is advisable that you should install any decent UML tool and do a small practice of one or two diagrams which will make you comfortable during interview.

(A) Give a small brief explanation of all Elements in activity diagrams?

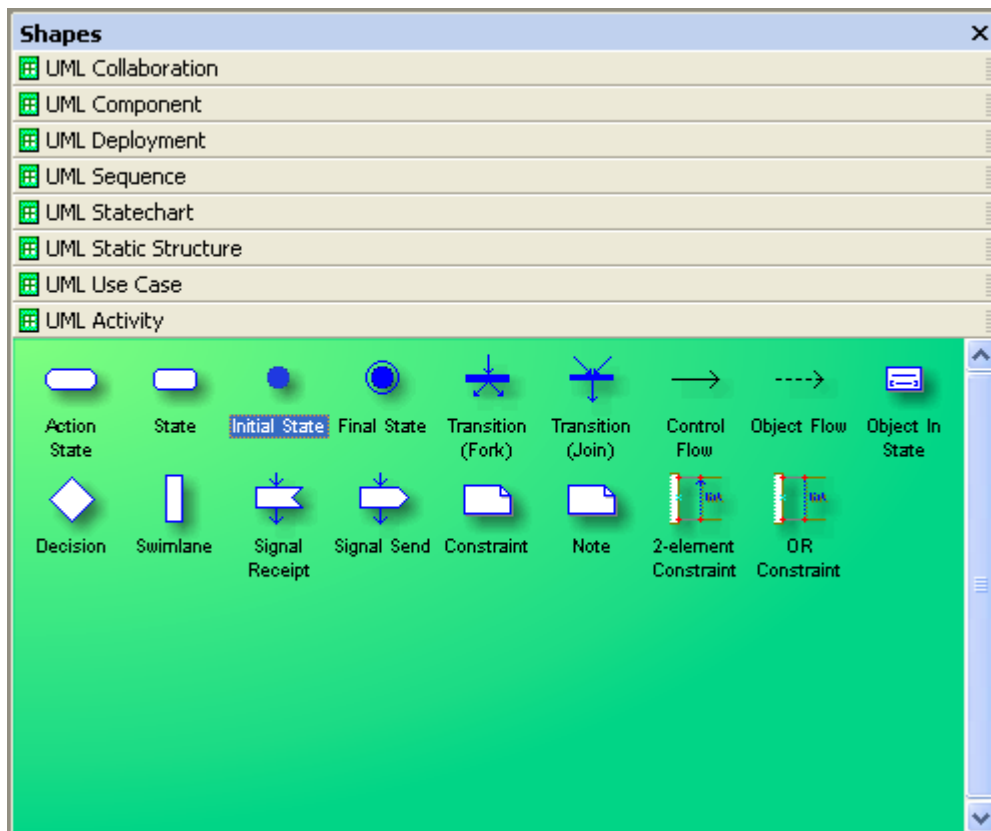

Figure :- 11.2 Elements of Activity Diagram

Action State :- It is a type of state that has an internal action and one outgoing event that would complete the internal action.

State :- It is a condition when following events occur:-

-
- √ Object satisfies a condition.
 - √ Or performs a action.
 - √ Or wait for a event to happen.

Initial State:- It represents a state before any event occurs.

Final State:- Represents completion of an activity.

Transition Fork::- Denotes beginning of parallel path activities.

Transition Join: - Denotes merging of parallel path activities.

Control Flow: - Represents relationship between two states and actions. In short it indicates that an object in one state is entering some other state.

Object Flow: - Connects an object flow state to control flow or action state.

Object in State: - Indicate the object's state after manipulation by multiple activities.

Decisions: - Defines if there are any condition's in the path.

Swim Lanes: - Assigns responsibility to action states.

Signal receipt Shape: - Used to replace an event label on a transition.

Signal Send Shape: - Used to replace an event label on a transition.

Constraint: - Conditions that must be maintained true in order the system is valid.

2-Element Constraint: - It show a constraint on two classes or associations.

OR constraint: - It show an OR constraint on two classes or associations.

(A) Explain Different elements of a collaboration diagram ?

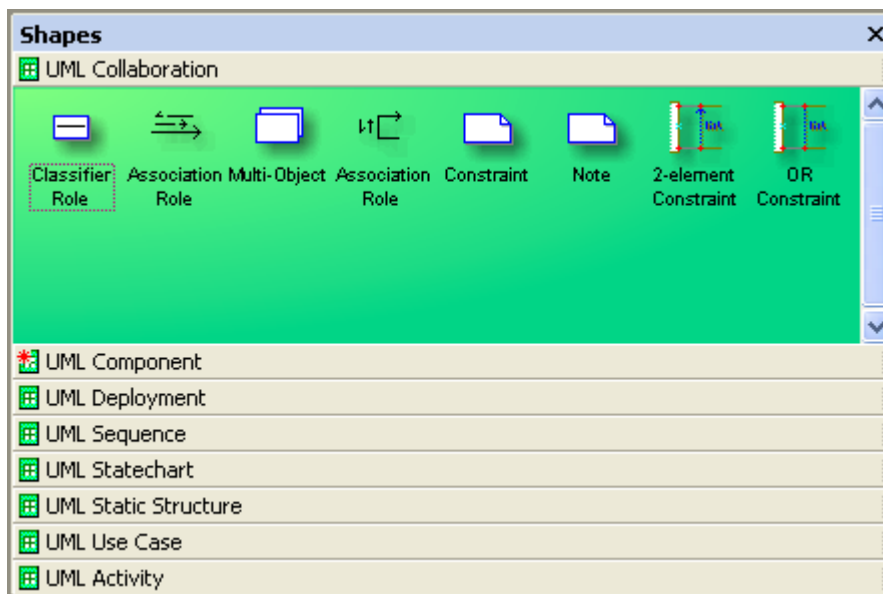

Figure :- 11.3 Elements of Collaboration Diagrams

Classifier Role :- It classifies a role.

Association Role :- It shows the relation between two classifier roles.

Multi-Object :- It used to show operation related to entire set of objects rather than on a single object.

Constraint :- Conditions which must be maintained as true in order that system is valid.

2-Element Constraint: - It shows a constraint on two classes or associations.

OR constraint: - It shows an OR constraint on two classes or associations.

(A) Explain Component diagrams ?

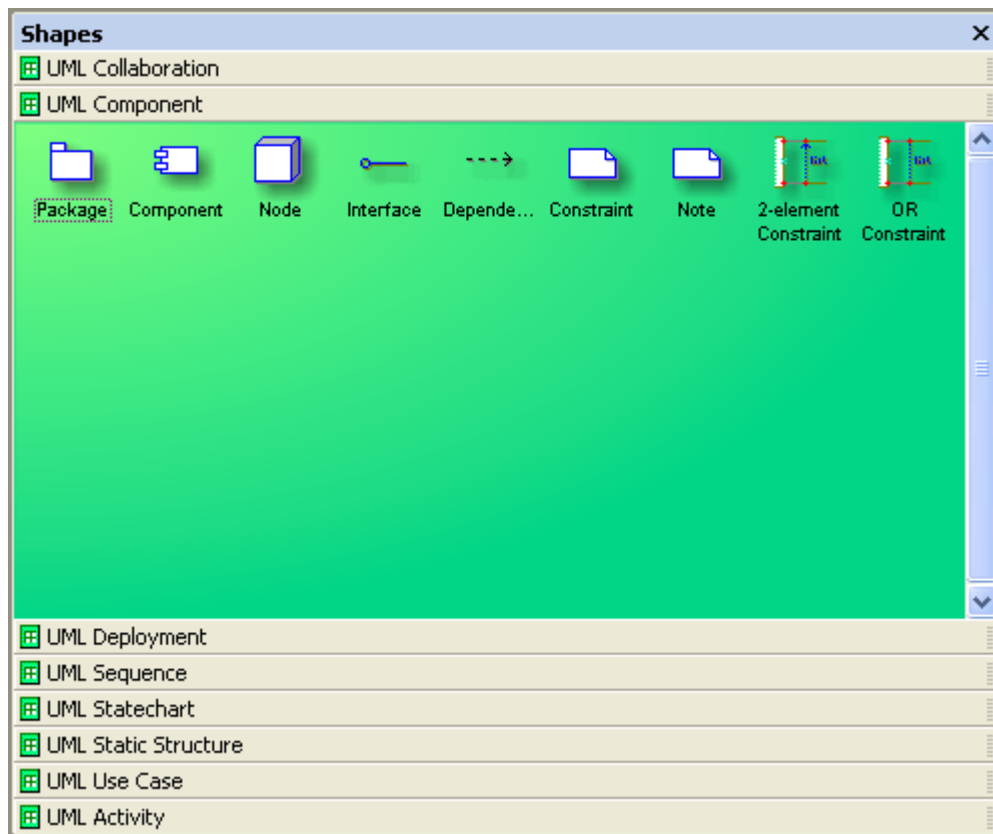

Figure :- 11.4 Elements of component diagrams

Package: - It logically make group of element of a UML model.

Component: - It's the actual implementation or physical module of a UML system.

Node: - A physical system which represents a processing resource, example PC or a host machine.

InterFace :- It specifies the externally operations of a class, component, package, or other element without specifying internal structure.

Dependency :- Shows relationship between two elements.

2-Element Constraint: - It shows a constraint on two classes or associations.

OR constraint: - It shows an OR constraint on two classes or associations.

(A) Explain all parts of a deployment diagram?

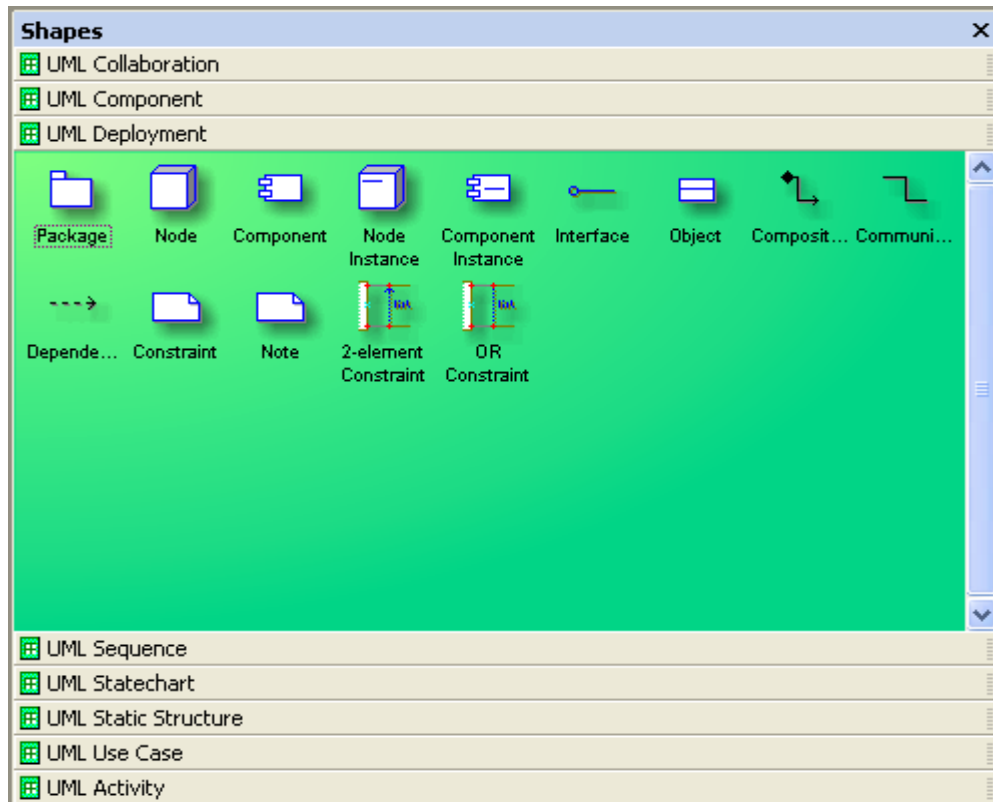

Figure : - 11.5 Elements of Deployment Diagram

Package: - It logically groups element of a UML model.

Node: - A physical system which represents a processing resource, example PC or a host machine.

Component: - It's the actual implementation or physical module of a UML system.

Node instance: - It's a runtime physical instance of a processing resource.

Component Instance: - It represents an implementation unit that has identity at run time and can contain objects. A component could be contained within a node instance.

InterFace :- It specifies the external operations of a class, component, package, or other element without specifying internal structure.

Object: - Instance of a class.

Composition shape: - It is a form of aggregation that indicates that a part may belong to only one element or life time of the element.

Communication: - How an actor Dependency: - Shows relationship between two elements.

2-Element Constraint: - It shows a constraint on two classes or associations.

OR constraint: - It shows an OR constraint on two classes or associations.

(A) Describe the various components in sequence diagrams?

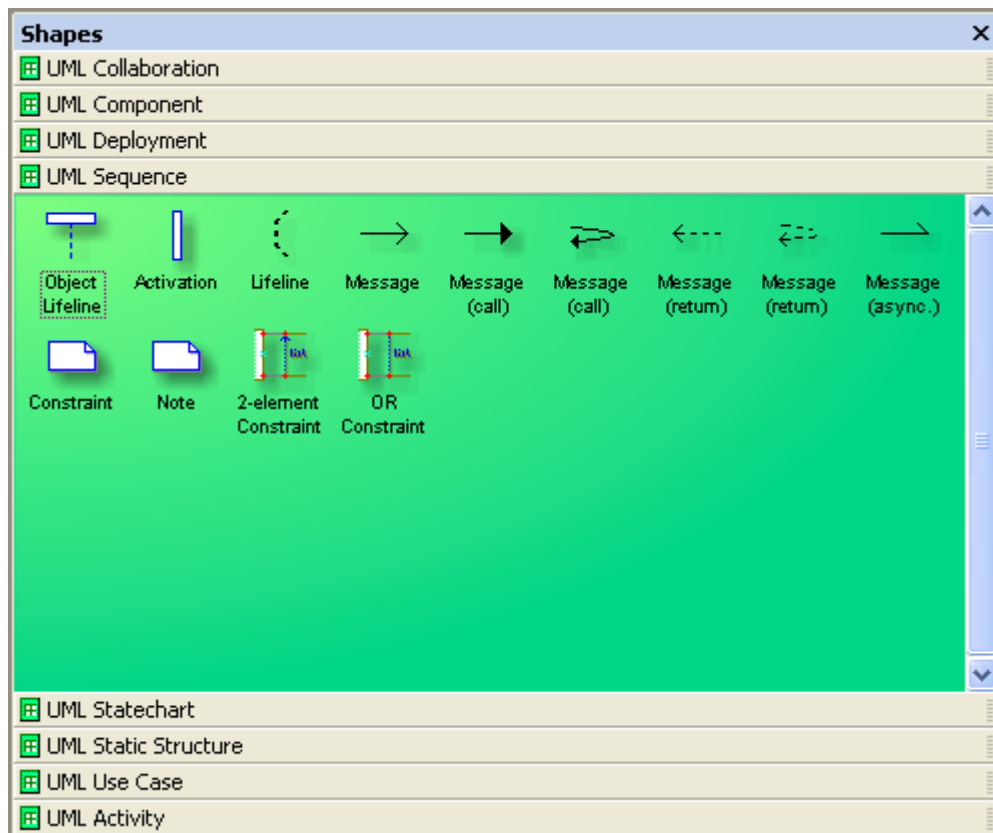

Figure :-11.6 Elements of Sequence diagrams

Object lifeline: - It represents the lifetime of an object creation and its destruction. If the object is created or destroyed during the time period the diagram represents, then the lifeline stops or starts at the appropriate point. An object's destruction is marked with a large X.

Activation: - It's time period during which actor is performing an action.

Lifeline :- This says that there exists some condition on the object lifetime.

Message: - It shows communication between objects that conveys information and results in an action.

Message (call):- It's same like message but also conveys some information and results in action.

All messages have same definition as the Message (Call) given above.

2-Element Constraint: - It shows a constraint on two classes or associations.

OR constraint: - It shows an OR constraint on two classes or associations.

(A) What are the element in State Chart diagrams ?

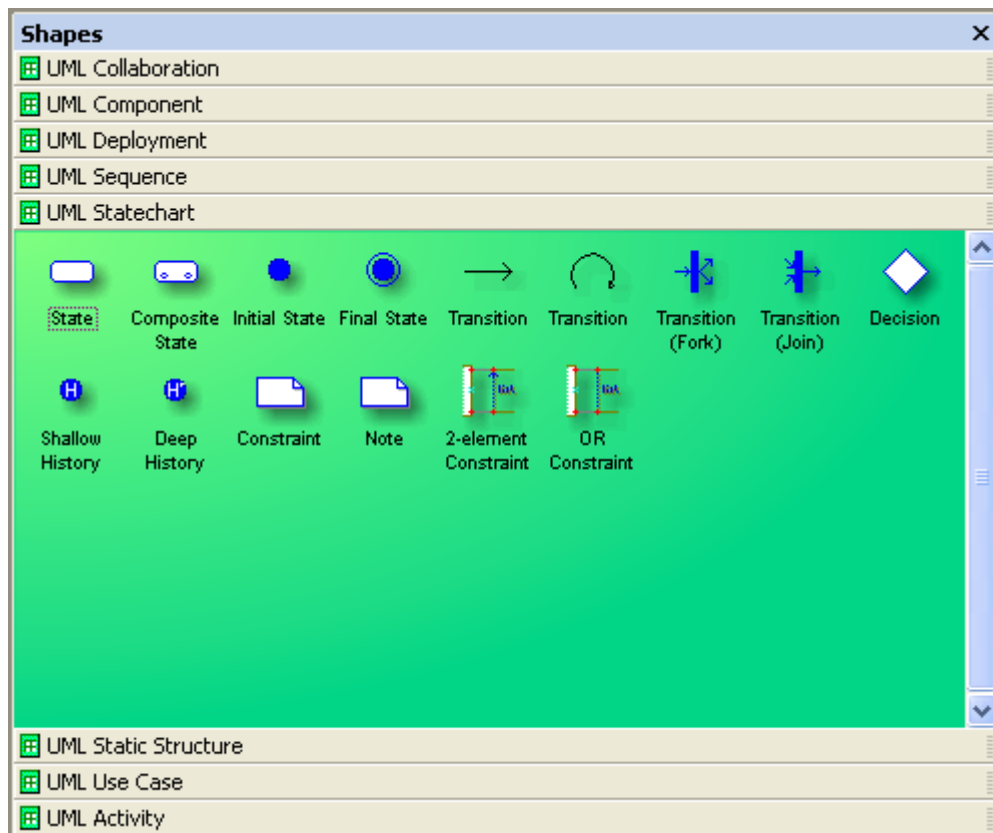

Figure :- 11.7 Elements of State Chart Diagrams

State: - It's a condition when following events occur:-

- √ Object satisfies a condition.
- √ Or performs a action.
- √ Or waits for a event to happen.

Composite State :- It has one or more sub states.

Initial State: - It represents a state before any event occurs.

Final State: - Represents completion of an activity.

Transition :- Shows the change of one state to other.

Transition Fork: - Denotes beginning of parallel path activities.

Transition Join: - Denotes merging of parallel path activities.

Decision: - Indicates condition to move to different states.

Shallow History: - Represents the state last visited. When a transition to the indicator fires, an object resumes the state it last had at the same level as the history indicator.

Deep history: A deep history allows you to return from whatever sub-state, whereas a shallow one only remembers the initial state of a composite state.

2-Element Constraint: - It shows a constraint on two classes or associations.

OR constraint: - It shows an OR constraint on two classes or associations.

(A) Describe different elements in Static Chart diagrams ?

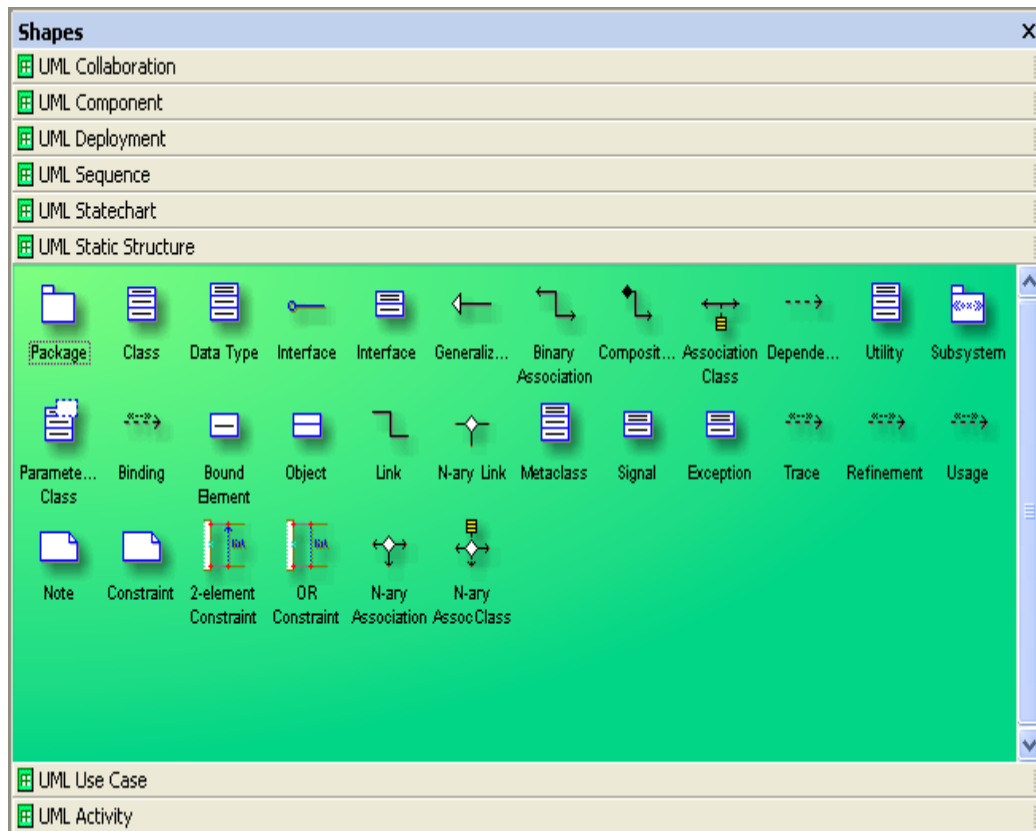

Figure :- 11.8 Elements of Static diagrams

Package: - It logically groups element of a UML model.

Class: - They describe set of objects with similar structure, behavior, and relationships.

Data Type :- A data type is an instance of the DataType metaclass defined in the UML metamodel. A data type declares a type of class attribute. This type is available as a string, you can include it when you define attributes for other elements in a model.

Interface :- It specifies the externally operations of a class, component, package, or other element without specifying internal structure.

Generalization: - It is a relationship between a specific element and a general element, such that the specific element is fully consistent with the general element and includes additional information (such as attributes and associations). For example, the classes Car, Bike, Cycle can all be specific elements of a more general abstract class element named vehicle.

Binary Association: - It's a relationship between two classes.

Composition: - A composition is a form of aggregation that indicates that a part may belong to only one whole and that the lifetime of the whole determines the lifetime of the part.

Dependency: - Shows relationship between two elements.

Utility : - Whatever Attributes and operations you define for a utility become global variables and procedures.

Subsystem: - It is a package that contains the contents of the entire system or an entire model within the system.

Parameterized class: - It is a template that describes a class with one or more unbound formal parameters.

Binding: - It is a kind of dependency that indicates a binding of parameterized class or template, parameters to actual values to create a bound, or no parameterized, element.

Bound element : - Parameters of the parameterized class are bound to actual values.

Object: - Represents instance of a class.

Link: - Represents Links between objects.

N-ary Link: - Represents link between an objects.

Meta-Class: - Whose instances are classes.

Signal: - Specifies stimulus between classes for which there is no reply. It is an element which can be generalized and is defined independently of the classes handling the signal.

Exception: - Signal raised because of bad execution.

Trace: - Indicates historical relationship between two elements.

Refinement: - Refinement is a kind of dependency that indicates a historical or derivation relationship between two elements with a mapping between them.

Usage : - Usage is a kind of dependency that indicates that one element requires the presence of another element for its correct implementation or functioning.

2-Element Constraint: - It shows a constraint on two classes or associations.

OR constraint: - It shows an OR constraint on two classes or associations.

(A) Explain the different elements of a Use Case ?

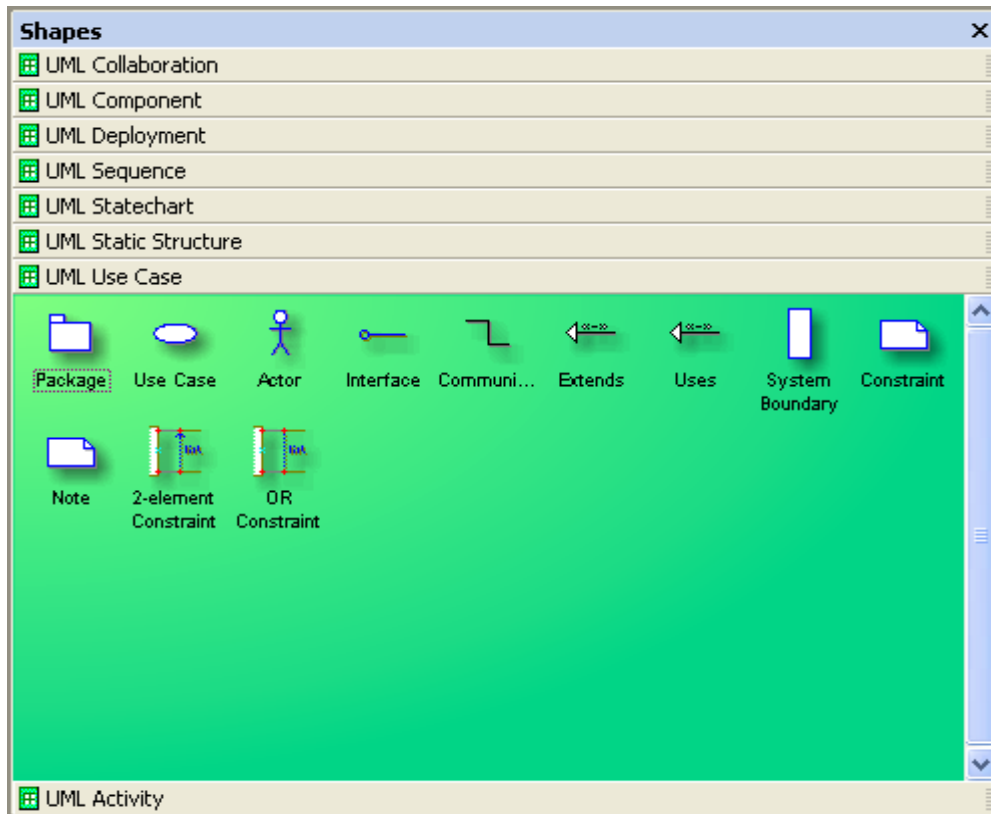

Figure :-11.9 Different Elements of Use Case

Package: - It logically groups element of a UML model.

Use Case :- It represents a set of events.

Actor : - Role played by an outside object.

Interface :- It specifies the externally operations of a class, component, package, or other element without specifying internal structure.

Communication: - How an actor Dependency shows relationship between two elements.

Extends: - Indicates that the elements come in parent child relationship where one element inherits other elements behavior.

Uses: - Here one element uses the other elements behavior. The main difference between Extends and Uses is a “Is a” and “Has a” relationship. “Is a” relationship defines a child parent relationship. Example “XYZ” is a child of “PQR”. “Has a” relationship defines an aggregation relationship that “XYZ” has a “BLUE SHIRT”.

System boundary: - Indicates the system boundary of a Use case.

2-Element Constraint: - It shows a constraint on two classes or associations.

OR constraint: - It shows an OR constraint on two classes or associations.

Twist: - What is the difference between Activity and sequence diagrams?

12. Project Management

Note:- This topic is meant specially for .NET programmers who are looking for better position rather than simple programmer jobs. Project management is not everybody's cup of tea. I have seen 10 year good decent technical guys do not get this position easily. But street smart programmers with average technical guys do really well. How much ever I try to cover this topic in this book.....it has so many variations that it's really difficult to predict every scenario of project management interview. But definitely I will try to cover the basics by which you can at least get a feel of what is asked.

(B) What is project management?

Applying knowledge, skills, tools, techniques in project and deliver project deliverables is a short definition of project management. It's basically managing project time, cost and scope.

(A) Is spending in IT projects constant through out the project?

Note:- It's a tricky question, to know how much depth you have regarding costing of projects.

Normally in initial stage of projects (requirement and design phase) the cost is very less (as you need maximum business analyst and architecture), but as the project proceeds cost factor starts increasing. The cost is maximum in coding phase (this is where you require programmers, project leads and project manager). Later when the project is in testing and acceptance phase cost is less as we will need only one or two programmers for removing bugs, than the whole team.

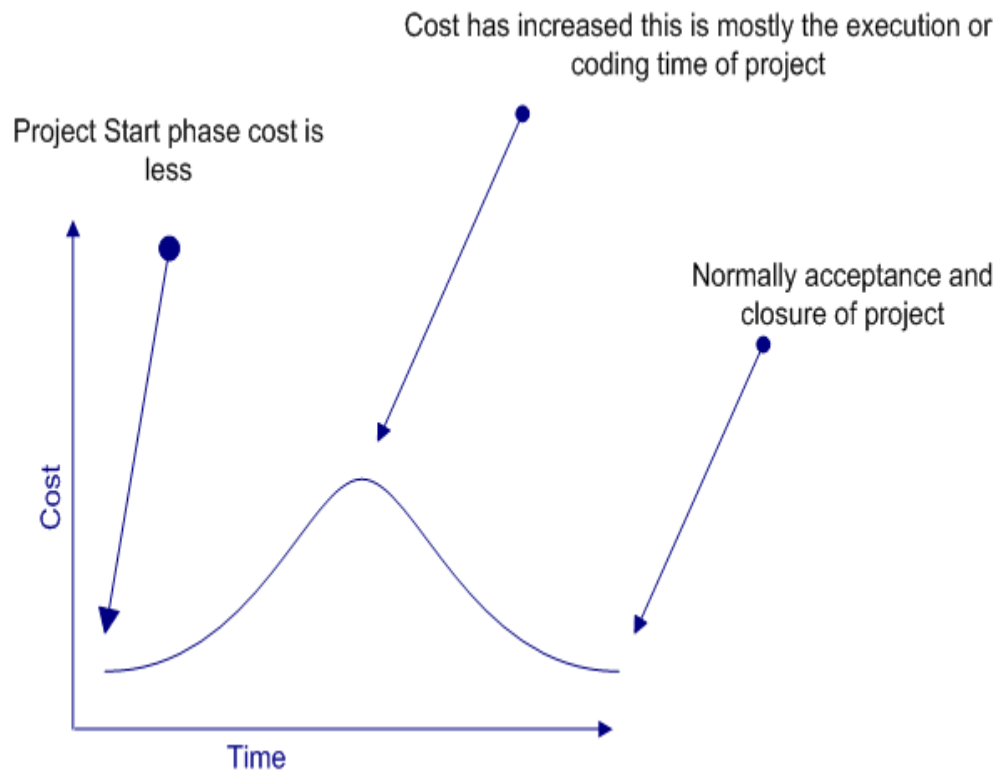

Figure :- 12.1 Graph showing cost variation in project.

(B) Who is a stakeholder ?

A stakeholder is anyone who has something to gain or lose as a result of the completion or failure of this project or phase

Note:- It's not only the end customer the stakeholder. Project managers, Project Lead, even programmers, testing department etc. are stake holders of project. So during project management interview whenever you refer stake holders be clear about the terminology.

(B) Can you explain project life cycle ?

Twist :- How many phases are there in software project ?

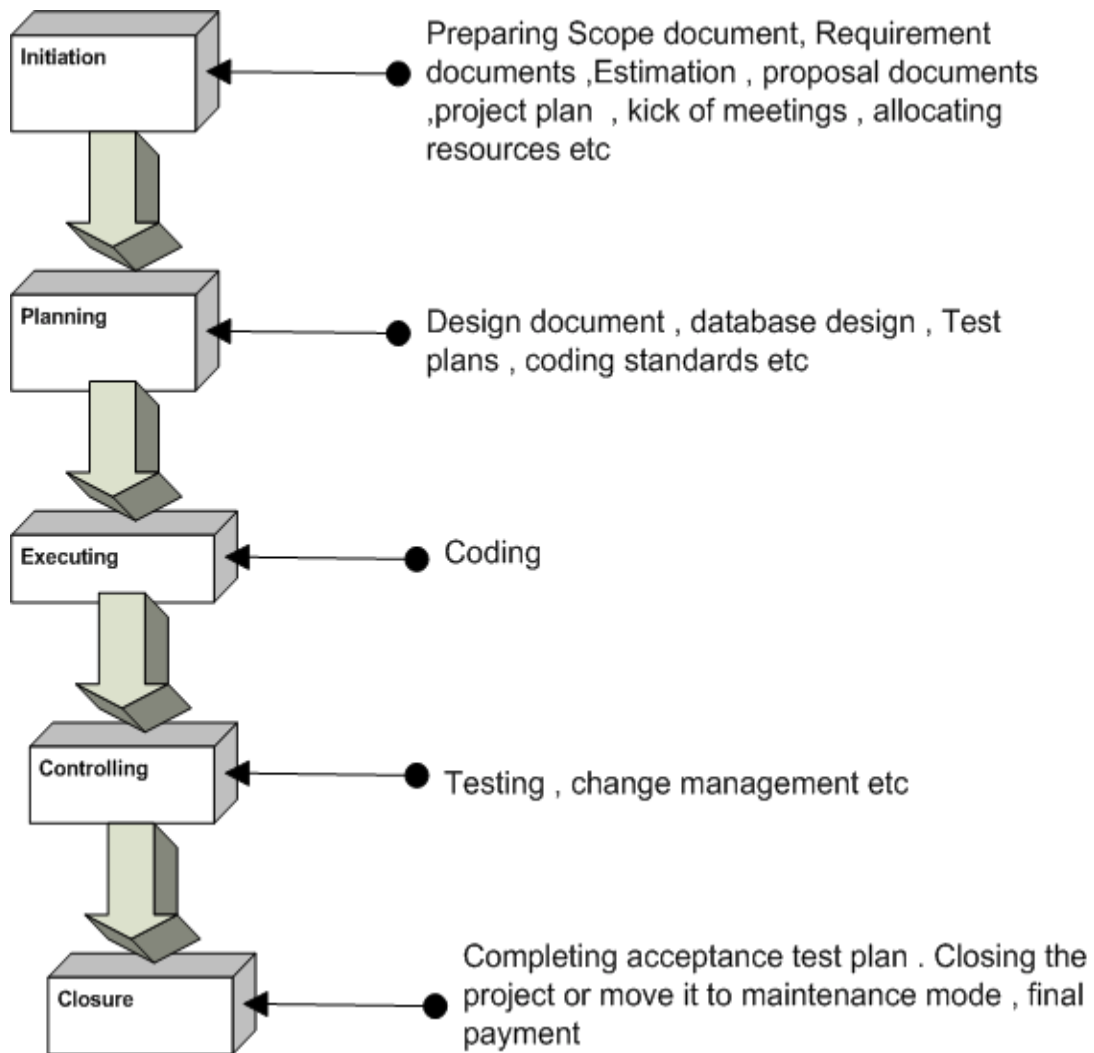

Figure :- 12.2 Life cycle of a project

There are five stages of any project initiating, planning, executing, controlling, and closeout. These are general phases and change according to domain. Example when writing a book

I will have following mappings initiating(contacting publishers,getting copy right etc), planning(Table of contents of book, Number of chapters , tool to use, chapter wise deadlines etc), executing(Actually writing the book), controlling(proof reading, language checks, page alignments etc), and closeout(Finally printing and on the shelf for sale). So this classification is at very broader level , for software development the above figure shows the mapping.

During Software project management interview expected answer is requirement phase, design phase, coding phase, testing phase and project closure. But you can just impress the answer by giving a general answer and then showing the mapping.

(B) Are risk constant through out the project ?

** Never say that risk is high through out the project.*

Risk is high at the start of projects, but by proper POC (Proof of concept) risk is brought in control.Good project managers always have proper risk mitigation plan at the start of project. As the project continues one by one risk is eliminated thus bringing down the risk.

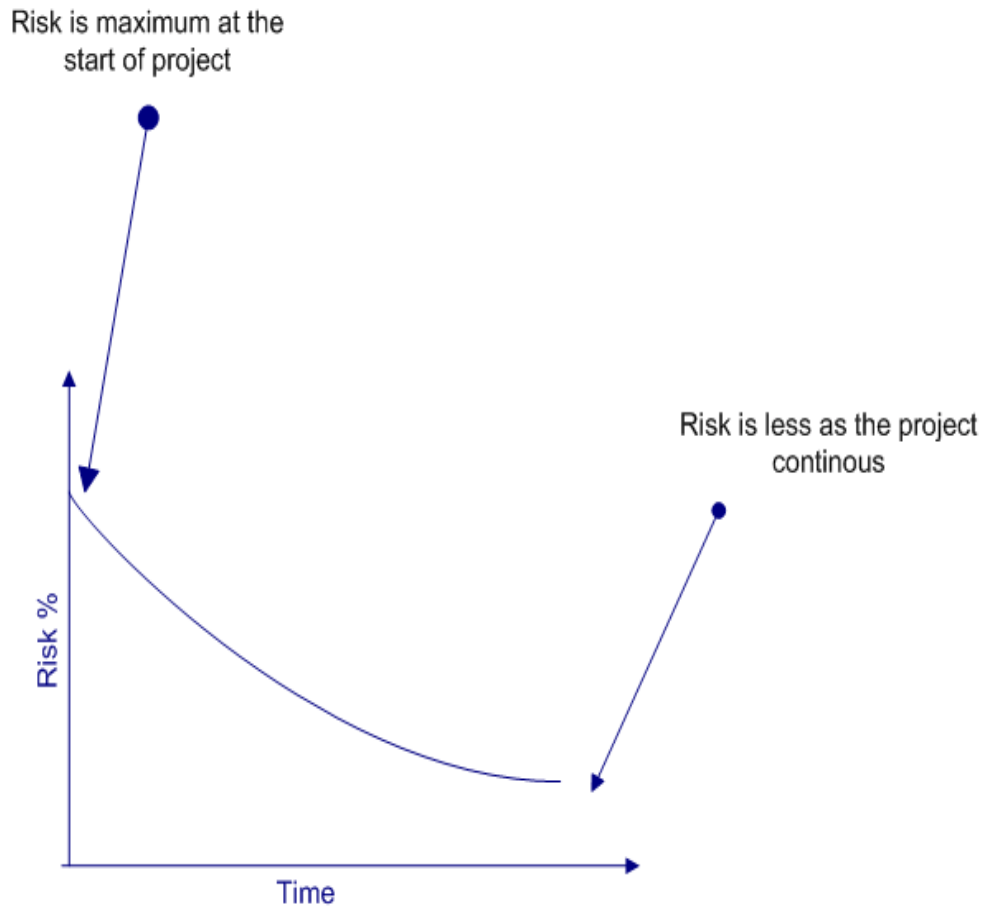

Figure :-12.3 Risk % according to project phases

(A)Can you explain different software development life cycles ?

Note:- This questions is asked to test that as a project manager do you have a know how of all the project life cycles.In PMP (Project management plan) you have to specify saying which

software development model you will follow. Definitely depending on client and project scenarios it's the project manager's responsibility to choose a development cycle.

SDLC (System Development Life Cycle) is overall process of developing information systems through multi stage process systems from investigation of initial requirements through analysis, design, implementation and maintenance. The days are gone when one COBOL programmer used to analyze, test and implement software systems. Systems have become complex, huge team members are involved, architects, analyst, programmers, testers, users etc. To manage this number of SDLC models have been created.

Following are popular models which are listed:-

- √ Waterfall Model.
- √ Spiral Model.
- √ Build and Fix model.
- √ Rapid prototyping Model.
- √ Incremental Model.

This section we will go into depth of different SDLC models.

Water Fall Model

This is the oldest model. It has sequence of stages; output of one stage becomes input of other.

Following are stages in Waterfall model:-

- √ System Requirement: - This is initial stage of the project where end user requirements are gathered and documented.
- √ System Design: - In this stage detail requirements, screen layout, business rules, process diagram, pseudo code and other documentations are prepared. This is first step in technical phase.
- √ Implementation: - Depending on the design document actual code is written here.
- √ Integration and Testing: - All pieces are brought together and tested. Bugs are removed in this phase.

√ Acceptance, Installation and Deployment: - This is final stage where software is put in production and runs actual business.

√ Maintenance: - This is least glamorous phase which runs forever. Code Changes, correction, addition etc are done in this phase.

Waterfall is suited for low risk in areas of User Interface and performance requirements, but high risk in budget and schedule predictability and control. Waterfall assumes that all requirements can be specified in advance. But unfortunately requirement grows and changes through various stages, so it needs feedback from one stage to other.

Spiral Model

Spiral Model removes the drawback of waterfall model, by providing emphasis to go back and reiterate earlier stages a number of times as project progresses. On broader level it's a series of short waterfall cycles, each producing an early prototype representing a part of entire project. It also helps demonstrate a Proof of Concept at early software life cycle.

Build and Fix Model

This is the way free-lancers work Write some code and keep modifying it until the customer is happy. This approach can be quite dangerous and risky.

Rapid Prototyping Model

This model is also called as Rapid Application Development. The initial emphasis is on creating prototype that look and acts like the desired product. Prototype can be created by using tools which is different from those used for final product. Once the prototype is approved, its discarded and real software development is started from scratch. The problem with this model is that sometimes the prototype moves ahead to become the final live product which can be bad from design point of view. It's a effective model but can have higher costing than other models as you require programmers during the initial phase of the software cycle.

Incremental Model

In this model we divide products into builds, where section of product are created and tested separately. Here errors are found in requirement phase itself, user feedback is taken for each stage and code is tested after it is written.

(B) What is triple constraint triangle in project management ?

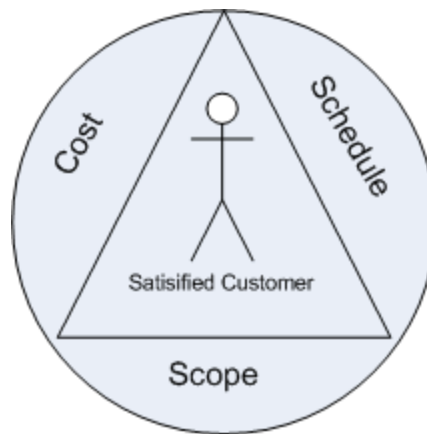

Figure :- 12.4 Project Management Triangle

Project Management triangle is depicted as Cost, Schedule and scope. These three aspects form the sides of triangle and the customer is the center point. As customer is always concerned about Cost, Scope and Schedule, so in order to get customer satisfaction project manager should deliver all scope in propose schedule and cost.

If we want to disturb any one of the legs then the other two legs get affected. Example if customer increases the scope then other two sides of the triangle also get affected a lot.

Note:- During project management interviews it's rare that you will be asked directly about constraint triangle. But when you are asked about what are the main factors that affect customer satisfaction you can refer this triangle.

(B)What is a project baselines ?

It defines a logical closure of any deliverable or cycle. Example you have completed the requirement phase with sign off from the client on the requirement document. So you put a baseline and say that further any changes to this document are change request. Versioning of source code is one type of baseline.

(B)What is effort variance?

Effort Variance = (Actual effort – Estimated Effort) / Estimated Effort.

(B)How is normally a project management plan document organized ?

PMP document forms the bible of a project. It has normally these sections :-

- √ Project summary
- √ Project organization hierarchy
- √ WBS / Activity list to be performed with schedule.
- √ Work product identification (In short who will do what)
- √ Project schedule(GANNT chart or PERT chart).
- √ Estimated Cost and completion.
- √ Project requirements.
- √ Risk identification.
- √ Configuration management section.
- √ Quality section.
- √ Action Item status.

(I)How do you estimate a project?

There are many techniques available for estimating a project:-

-
- √ Function points
 - √ Use Case points
 - √ WBS etc etc.

(B)What is CAR (Causal Analysis and Resolution)?

The basic purpose of CAR is to analyze all defects, problems and good practices/positive triggers in projects, perform a root cause analysis of the same, identify respective corrective and preventive actions and track these to closure. The advantage of CAR is that root causes are scientifically identified and their corrective and preventive actions are carried out. CAR needs to be performed at project initiation, all phase and project ends and on a monthly basis. Fishbone diagram is one of the ways you can do CAR.

(B) What is DAR (Decision Analysis and Resolution) ?

Decision Analysis and Resolution is to analyze possible decisions using a formal evaluation process that identifies alternatives against established criteria.

Example in a project you are said to use third party tools so you will not depend on only one tool but evaluate three to four more tools so that in case of problems you have alternatives. This is called as DAR

(B) What is a fish bone diagram ?

Twist:- What is Ishikawa diagram ?

Dr. Kaoru Ishikawa, invented the fishbone diagram. Therefore, it can be also referred as Ishikawa diagram.

Fishbone diagram is an analysis diagram which provides a systematic way of looking at effects and the causes that create or contribute to those effects. Because of the function of the fishbone diagram, it may be referred to as a cause-and-effect diagram. The design of the diagram looks much like the skeleton of a fish. Therefore, it is often referred to as the fishbone diagram.

Fishbone diagram helps in categorizing potential causes of problems or issues in an orderly way and in identifying root causes.

Below is a sample fish bone diagram which shows why a project dead line was not met. The middle arrow is the main problem "Deadline not met". Then we start analyzing other problems which has led to this problem. Example There is client problem -- as he is always changing the requirement -- this is caused because the company did not sign the SRS --- and this happened as proper project management procedures where not at place. So to solve this problem we either appoint a project manager or give training on project management to senior team members.

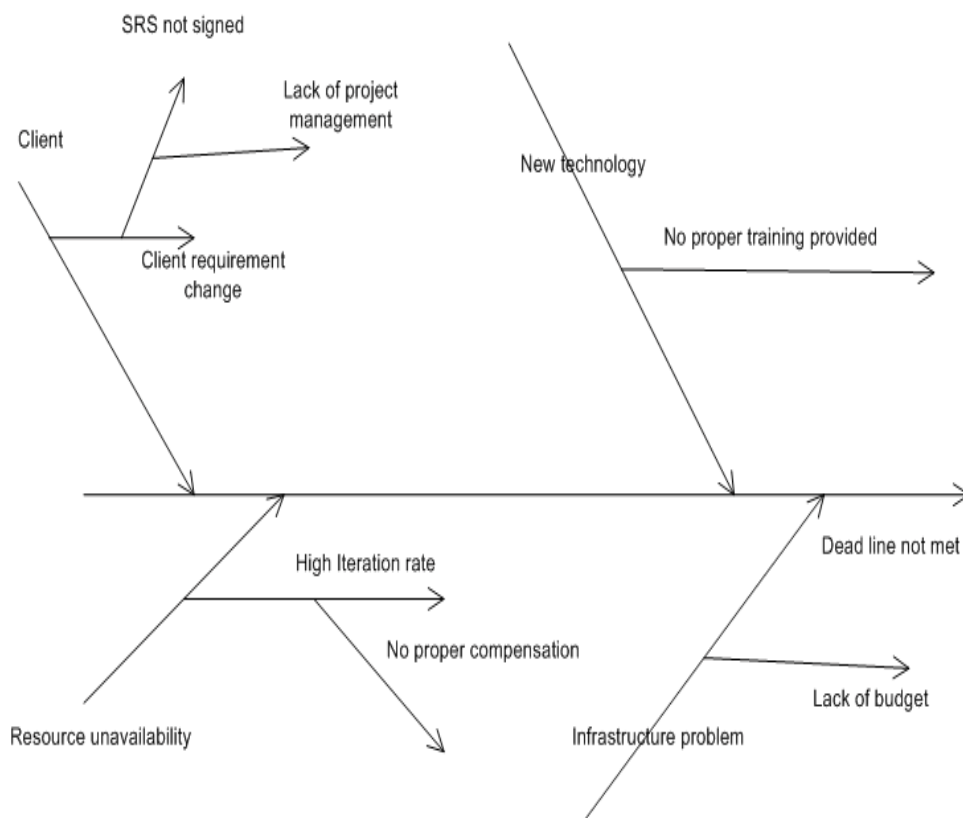

Figure :- 12.5 Sample fish bone diagram

(B) What is pareto principle ?

Twist :- What is 80/20 principle ?

Pareto principle also paraphrased as 80/20 principle is simple effective problem tackling way in management. It says that 20% of your problems lead to other 80 % of problems. So rather than concentrating on the 80% of problem if you concentrate on 20% of problems you can save lot of trouble. So in pareto you analyze the problems and only concentrate on 20% of your vital problems. In projects the first 10% and the last 10% of project form the vital part of project.

(B)How do you handle change request?

Normally change request are handled by preparing an Impact analysis document and then doing re-estimation. Example you have an on going project, which has a customer table. Now customer want to also have addresses assigned to it. So you normally raise a change request and then do an impact analysis of the same. Depending on the impact you estimate and let know the client about the financial aspect of the project. Once client sign off or the upper management agrees to the change request you move ahead with implementation.

(I)What is internal change request?

Internal change request are not normally billable change request, it has no financial gains from the client. Example your architecture division of your company has said in mid of the project that the architecture has to be modified. Definitely this has nothing to do with the client, but you make changes to it this is called as Internal change request.

(B)What is difference between SITP and UTP in testing ?

UTP (Unit Test Plan) are done at smallest unit level or stand alone mode. Example you have Customer and invoicing module. So you will do test on Customer and Invoice module independently. But later when we want test both customer and invoice in one set we integrate them and test it. So that's is SITP (System Integration Test Plan)

UTP can be done using NUNIT. Unit testing is done normally by developers and System testing is done normally by testing department in integration mode.

(B)What is the software you have used for project management?

Many companies have there own software defined. There are many project management software available at this moment in market but this can vary from company to company

, worst it can vary from project to project. But Microsoft project is the most used software at this moment. So just brush your skills on Microsoft project, it's used heavily across industry.

(I) What are the metrics followed in project management?

Twist: - What metrics will you look at in order to see the project is moving successfully?

Most metric sets deal with a variation of these attributes and are chosen to help project managers gain insight into their product (size, software quality, rework), process (rework, software quality) and project (effort, schedule).

But below is a broader classification :-

Project Management Metrics

milestone metrics

- √ number of milestones
- √ number of proved requirements per milestone
- √ controlling level metrics

risk metrics

- √ probability of resources availability
- √ probability of the requirements validity
- √ risk indicators (long schedules, inadequate cost estimating, excessive paperwork, error-prone modules, canceled projects, excessive schedule pressure, low quality, cost overruns, creeping user requirements, excessive time to market, unused or unusable software, unanticipated acceptance criteria, hidden errors)

- √ application risk metrics

workflow metrics

- √ walkthrough metrics

√ traceability metrics

√ variance metrics

controlling metrics

√ size of control elements

√ structure of control elements

√ documentation level

√ tool application level

management database metrics

√ data quality metrics

√ management data complexity

√ data handling level (performance metrics)

√ visualization level

√ safety and security metrics

Quality Management Metrics

customer satisfaction metrics

√ characteristics size metrics

√ characteristics structure metrics

√ empirical evaluation metrics

√ data presentation metrics

review metrics

√ number of reviews in the process

√ review level metrics

-
- √ review dependence metrics
 - √ review structure metrics
 - √ review resources metrics

productivity metrics

- √ actual vs. planned metrics
- √ performance metrics
- √ productivity vs. quality metrics

efficiency metrics

- √ time behavior metrics
- √ resources behavior metrics
- √ actual vs. Planned metrics

quality assurance metrics

- √ quality evaluation metrics
- √ error prevention metrics
- √ measurement level
- √ data analysis metrics

Configuration Management Metrics

change control metrics

- √ size of change
- √ dependencies of changes
- √ change interval metrics
- √ revisions metrics

version control metrics

- √ number of versions
- √ number of versions per customer
- √ version differences metrics
- √ releases metrics (version architecture)
- √ data handling level

Note:- Following are some questions who do not have a specific answer and vary from person to person or are out of the scope of book. This book will list down the questions just go through them.

(B)You have people in your team who do not meet there deadlines or do not perform what are the actions you will take ?

Twist :- Two of your resources have conflicts between them how would you sort it out ?

In such kind of question they want to see your delegation skills. The best answer to this question is a job of a project manager is managing projects and not problems of people, so I will delegate this work to HR or upper authority.... Thanks to my Project Manager for this beautiful answer.

(B)What is black box testing and White box testing?

Black box testing is also termed as functional testing. It ignores how the internal functionality of a system works and depends only what are the outputs on specified inputs. Source code availability is not an important in back box testing. Black box testing is mostly to ensure that it meets the user functionality.

According to IEEE standards following are characteristics of Black box testing:-

- √ “Testing that ignores the internal mechanism of a system or component and focuses solely on the outputs generated in response to selected inputs and execution conditions;”

√ “Testing conducted to evaluate the compliance of a system or component with specified functional requirements.”

One of the ways of black box testing is Manual testing what the tester performs. For instance you can install the application on a machine and tester starts testing is a type of black box testing. In this case the tester is completely unaware of the how the program logic flows and how its coded etc.

White box testing is opposite to Black box it requires internal know how of how the logic flows. As this testing needs know how of the internal structure it can only be done programmers. Unit testing is one of the ways of doing White box testing in which programmers use NUnit or JUnit to test each class individually. White box testing can be done by programmer by either stepping through the code or testing the classes and components in isolation.

(B) What’s the difference between Unit testing, Assembly testing and Regression testing?

Unit testing is also called as Component testing. Unit testing ensures that reliable program unit meets their requirements. Unit testing is normally conducted by programmer under the supervision of the project lead or the team Lead. Main objective of this testing is to test each unit in isolation and individually. This is done by knowing what are the inputs to the unit and what the expected outputs for the same. Unit testing is a white box activity. Unit test normally comes in the implementation phase of the project.

For instance in the below figure we are trying to do unit testing on the customer class. So we create the object of Customer class assign “CustomerCode” and “Age” property and check for the response. For instance in this condition we tried to pass a non-numeric value to the “Age” property and the class threw an error saying “Age should be numeric”. So here the basic unit testing entity is your class.

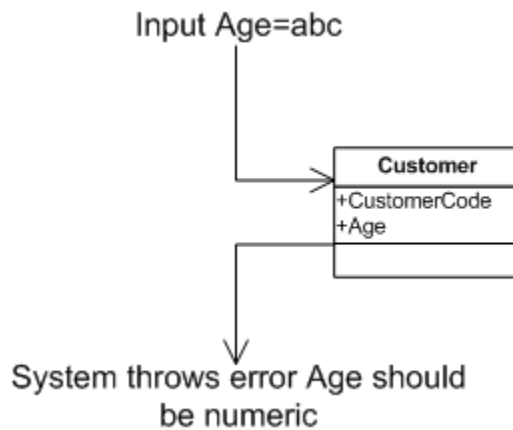

Figure 12.6 : - Unit testing for sample Customer class

But unit testing is not limited to a component, object or function. So definition of a unit testing will depend on the approach. Below are some examples of unit testing:-

- √ Check points in UI like tab orders, error messages, look and feel etc.
- √ Class, object, component level testing as said previously.
- √ In case of functional programming can be a simple method or function.
- √ Logic testing for algorithms. Some projects can have some critical algorithm for instance some kind of custom sorting, security implementation etc. So that logic can be tested independently.

But the general thumb rule of what is Unit in Unit testing is that the module self contained and by itself.

Assembly testing goes one step ahead than unit testing. It demonstrates that can the modules interact in a correct, stable and proper manner as defined by the functional specifications provided by the client. Assembly testing is Black box testing style and also called as Integration testing. For instance in the above unit test of the “Customer” class, testing was done in isolation. But in actually the “Customer” class is not going to be stand alone rather it will be used more in conjunction with the “Product” class and also will have UI to do the same. So in short the “Customer” class will work with two more entity

one is the “UI” and the other is the “Product” class. So normally assembly testing is done through UI but not necessarily.

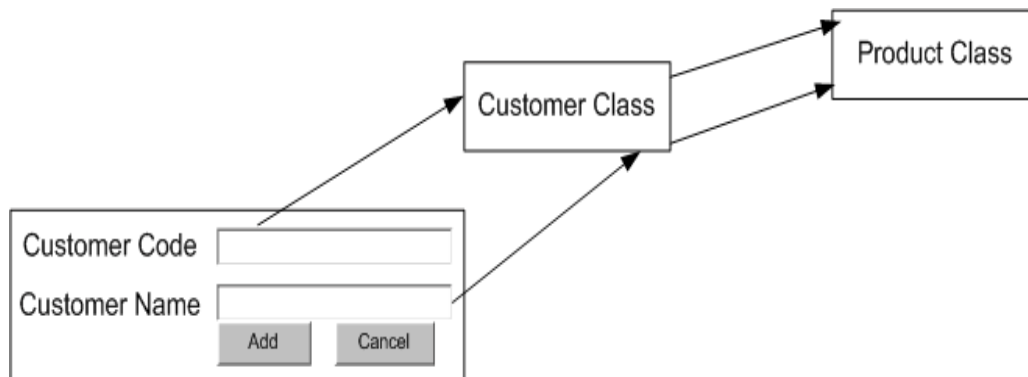

Figure 12.7 : - Integration Testing

The above figure defines a simple scenario for integration testing. The same “Customer” class is now tested with the “UI” and “Product” to see if the interaction between them matches according to functional specifications.

Regression testing ensures that application function properly even if there are changes or enhancements to system. For instance you change the “Product” class still you will run all the test cases for “Product”, “Customer” and “UI” just to make sure that any changes in “Product” class does not affect interaction with other entities. So you will see when testers do a regression testing they run all the scripts to ensure that nothing has been affected.

(I)What is V model in testing?

V model map’s the type of test to the stage of development in a project.

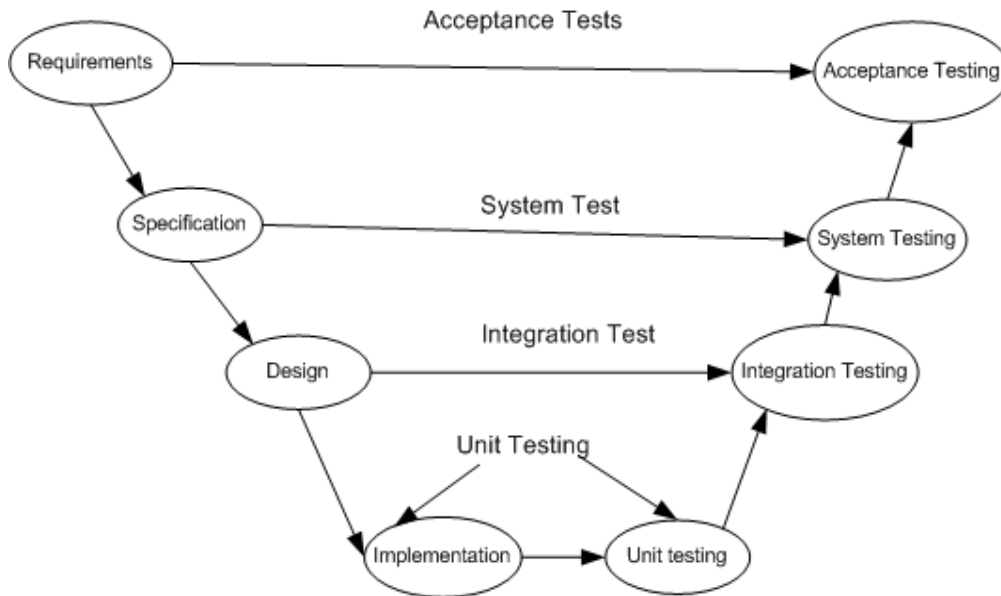

Figure 12.8 : - V Model

Unit Testing

Starting from the bottom the first test level is "Unit Testing". It involves checking that each feature specified in the "Component Design" has been implemented in the component.

In theory an independent tester should do this, but in practice the developer usually does it, as they are the only people who understand how a component works. The problem with a component is that it performs only a small part of the functionality of a system, and it relies on co-operating with other parts of the system, which may not have been built yet. To overcome this, the developer either builds, or uses special software to trick the component into believe it is working in a fully functional system.

Integration Testing

As the components are constructed and tested they are then linked together to check if they work with each other. It is a fact that two components that have passed all their

tests, when connected to each other produce one new component full of faults. These tests can be done by specialists, or by the developers.

Integration Testing is not focused on what the components are doing but on how they communicate with each other, as specified in the "System Design". The "System Design" defines relationships between components.

The tests are organized to check all the interfaces, until all the components have been built and interfaced to each other producing the whole system.

System Testing

Once the entire system has been built then it has to be tested against the "System Specification" to check if it delivers the features required. It is still developer focused, although specialist developers known as systems testers are normally employed to do it.

In essence System Testing is not about checking the individual parts of the design, but about checking the system as a whole. In fact it is one giant component.

System testing can involve a number of specialist types of test to see if all the functional and non-functional requirements have been met. In addition to functional requirements these may include the following types of testing for the non-functional requirements:

- √ Performance - Are the performance criteria met?
- √ Volume - Can large volumes of information be handled?
- √ Stress - Can peak volumes of information be handled?
- √ Documentation - Is the documentation usable for the system?
- √ Robustness - Does the system remain stable under adverse circumstances?

There are many others, the need for which is dictated by how the system is supposed to perform.

Acceptance Testing

Acceptance Testing checks the system against the "Requirements". It is similar to systems testing in that the whole system is checked but the important difference is the change in focus:

Systems testing checks that the system that was specified has been delivered. Acceptance Testing checks that the system will deliver what was requested.

The customer should always do acceptance testing and not the developer . The customer knows what is required from the system to achieve value in the business and is the only person qualified to make that judgment. This testing is more of getting the answer for whether is the software delivered as defined by the customer. It's like getting a green flag from the customer that the software is up to the expectation and ready to be used.

(B)How do you start a project?

Left to the readers

(B)How did you do resource allocations?

Left to the readers

(I) How will you do code reviews ?

The way in which code reviews are done change from person to person and also company to company. But the normally when a project is started project people define their architecture, coding standards etc in their design document. So before starting the code review you will have go through the standards defined in the project.

(A)What is CMMI?

It is a collection of instructions an organization can follow with the purpose to gain better control over its software development process.

(A) What are the five levels in CMMI?

There are five levels of the CMM. According to the SEI,

Level 1 - Initial

At maturity level 1, processes are usually ad hoc and the organization usually does not provide a stable environment. Success in these organizations depends on the competence and heroics of people in the organization and not on the use of proven processes. In spite of this ad hoc, chaotic environment, maturity level 1 organizations often produce products

and services that work; however, they frequently exceed the budget and schedule of their projects.

Maturity level 1 organizations are characterized by a tendency to over commit, abandon processes in the time of crisis, and not be able to repeat their past successes again.

Level 2 - Repeatable

At maturity level 2, software development successes are repeatable. The organization may use some basic project management to track cost and schedule.

Process discipline helps to ensure that existing practices are retained during times of stress. When these practices are in place, projects are performed and managed according to their documented plans.

Project status and the delivery of services are visible to management at defined points (for example, at major milestones and at the completion of major tasks).

Basic project management processes are established to track cost, schedule, and functionality. The necessary process discipline is in place to repeat earlier successes on projects with similar applications.

Level 3 - Defined

At maturity level 3, processes are well characterized and understood, and are described in standards, procedures, tools, and methods.

The organization's set of standard processes, which is the basis for level 3, is established and improved over time. These standard processes are used to establish consistency across the organization. Projects establish their defined processes by the organization's set of standard processes according to tailoring guidelines.

The organization's management establishes process objectives based on the organization's set of standard processes and ensures that these objectives are appropriately addressed.

A critical distinction between level 2 and level 3 is the scope of standards, process descriptions, and procedures. At level 2, the standards, process descriptions, and procedures may be quite different in each specific instance of the process (for example, on a particular project). At level 3, the standards, process descriptions, and procedures for a project are tailored from the organization's set of standard processes to suit a particular project or organizational unit.

Level 4 - Managed

Using precise measurements, management can effectively control the software development effort. In particular, management can identify ways to adjust and adapt the process to particular projects without measurable losses of quality or deviations from specifications.

Sub processes are selected that significantly contribute to overall process performance. These selected sub processes are controlled using statistical and other quantitative techniques.

A critical distinction between maturity level 3 and maturity level 4 is the predictability of process performance. At maturity level 4, the performance of processes is controlled using statistical and other quantitative techniques, and is quantitatively predictable. At maturity level 3, processes are only qualitatively predictable.

Level 5 - Optimizing

Maturity level 5 focuses on persistently improving process performance through both incremental and innovative technological improvements. Quantitative process-improvement objectives for the organization are established, continually revised to reflect changing business objectives, and used as criteria in managing process improvement. The effects of deployed process improvements are measured and evaluated against the quantitative process-improvement objectives. Both the defined processes and the organization set of standard processes are targets of measurable improvement activities.

Process improvements to address common causes of process variation and measurably improve the organization's processes are identified, evaluated, and deployed.

Optimizing processes that are nimble, adaptable and innovative depends on the participation of an empowered workforce aligned with the business values and objectives of the organization. The organization's ability to rapidly respond to changes and opportunities is enhanced by finding ways to accelerate and share learning.

A critical distinction between maturity level 4 and maturity level 5 is the type of process variation addressed. At maturity level 4, processes are concerned with addressing special causes of process variation and providing statistical predictability of the results. Though processes may produce predictable results, the results may be insufficient to achieve the established objectives. At maturity level 5, processes are concerned with addressing common causes of process variation and changing the process (that is, shifting the mean of the

process performance) to improve process performance (while maintaining statistical probability) to achieve the established quantitative process-improvement objectives.

Note: - I am sure during interview specially the SQA guys expect all the different levels of CMMI to be in mind. So below is the figure which will help you remembering the same.

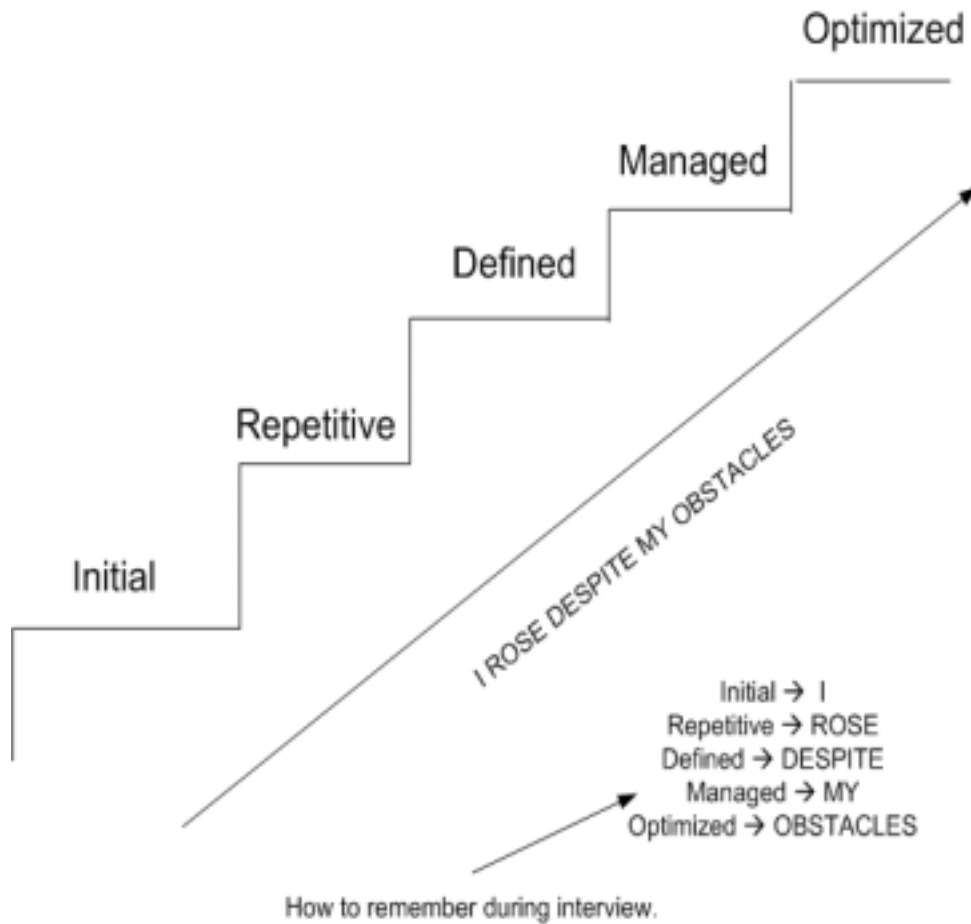

Figure 12.9 : - CMMI Levels

(A) What is continuous and staged representation?

CMMI contains 25 key process areas which organization can follow to adapt CMMI.

- √ Causal Analysis and Resolution (CAR)
- √ Configuration Management (CM)
- √ Decision Analysis and Resolution (DAR)
- √ Integrated Project Management (IPM)
- √ Integrated Supplier Management (ISM)
- √ Integrated Teaming (IT)
- √ Measurement and Analysis (MA)
- √ Organizational Environment for Integration (OEI)
- √ Organizational Innovation and Deployment (OID)
- √ Organizational Process Definition (OPD)
- √ Organizational Process Focus (OPF)
- √ Organizational Process Performance (OPP)
- √ Organizational Training (OT)
- √ Product Integration (PI)
- √ Project Monitoring and Control (PMC)
- √ Project Planning (PP)
- √ Process and Product Quality Assurance (PPQA)
- √ Quantitative Project Management (QPM)
- √ Requirements Development (RD)
- √ Requirements Management (REQM)
- √ Risk Management (RSKM)
- √ Supplier Agreement Management (SAM)
- √ Technical Solution (TS)

√ Validation (VAL)

√ Verification (VER)

The method by which company wants to adapt to CMMI is called a representation. So either organization can adapt for staged or continuous representation.

In the continuous representation process areas are organized by functional area. For example, a company interested to improve its Project Management capability would focus on IPM, ISM, IT, PMC, PP, QPM, RSKM and SAM.

Process Management

OID - Organizational Innovation and Deployment

OPD - Organizational Process Definition

OPF - Organizational Process Focus

OPP - Organizational Process Performance

OT - Organizational Training

Project Management

IPM - Integrated Project Management

ISM - Integrated Supplier Management

IT - Integrated Teaming

PMC - Project Monitoring and Control

PP - Project Planning

QPM - Quantitative Project Management

RSKM - Risk Management

SAM - Supplier Management Agreement

Engineering

PI - Product Integration

REQM - Requirements Management

RD - Requirements Development

TS - Technical Solution

VAL - Validation

VER - Verification

Support

CAR - Casual Analysis and Resolution

CM - Configuration Management

DAR - Decision Analysis and Resolution

MA - Measurement and Analysis

OEI - Organizational Environment for Integration

PPQA - Process and Product Quality Assurance

Staged representation

While in staged representation the concept of levels comes in to picture. In the staged representation process areas are organized by organizational maturity level. For example, a company interested to obtain a Maturity Level 2 rating would require company processes covering all of the Maturity Level 2 process areas.

Maturity Levels 2

CM - Configuration Management

MA - Measurement and Analysis

PMC - Project Monitoring and Control

PP - Project Planning

PPQA - Process and Product Quality Assurance

REQM - Requirements Management

SAM - Supplier Management Agreement

Maturity Level 3

DAR - Decision Analysis and Resolution

IPM - Integrated Project Management

ISM - Integrated Supplier Management

IT - Integrated Teaming

OEI - Organizational Environment for Integration

OPD - Organizational Process Definition

OPF - Organizational Process Focus

OT - Organizational Training

PI - Product Integration

RD - Requirements Development

RSKM - Risk Management

TS - Technical Solution

VAL - Validation

VER - Verification

Maturity Level 4

QPM - Quantitative Project Management

OPP - Organizational Process Performance

Maturity Level 5

CAR - Casual Analysis and Resolution

OID - Organizational Innovation and Deployment

(A)Can you explain the process areas?

Note: - No one is going to ask such a question. But they would like to know at least the purpose of each KPA. Second they would like to know what you did to attain compatibility to these process areas. For instance you say that you did Organizational Process Definition. They would like to know how you did it. For instance you can justify it by saying that you made standard documents for coding standards which was then followed at the organization level for reference. Normally every one follows process it's only that they do not know. So try to map the KPA to the process what you follow. The only purpose to paste all the KPA is if in case you are looking for some higher positions in bug companies they really expect you to speak in term of KPA rather than generic term. This whole stuff can be like a quick reference for you before entering the interview room.

Each process area is defined by a set of goals and practices. There are two categories of goals and practices: generic and specific. Generic goals and practices are a part of every process area. Specific goals and practices are specific to a given process area. A process area is satisfied when company processes cover all of the generic and specific goals and practices for that process area.

Generic goals and practices

Generic goals and practices are a part of every process area.

GG 1 Achieve Specific Goals

GP 1.1 Perform Base Practices

GG 2 Institutionalize a Managed Process

GP 2.1 Establish an Organizational Policy

GP 2.2 Plan the Process

GP 2.3 Provide Resources

GP 2.4 Assign Responsibility

GP 2.5 Train People

GP 2.6 Manage Configurations

GP 2.7 Identify and Involve Relevant Stakeholders

GP 2.8 Monitor and Control the Process

GP 2.9 Objectively Evaluate Adherence

GP 2.10 Review Status with Higher Level Management

GG 3 Institutionalize a Defined Process

GP 3.1 Establish a Defined Process

GP 3.2 Collect Improvement Information

GG 4 Institutionalize a Quantitatively Managed Process

GP 4.1 Establish Quantitative Objectives for the Process

GP 4.2 Stabilize Subprocess Performance

GG 5 Institutionalize an Optimizing Process

GP 5.1 Ensure Continuous Process Improvement

GP 5.2 Correct Root Causes of Problems

Process areas

The CMMI contains 25 key process areas indicating the aspects of product development that are to be covered by company processes.

Causal Analysis and Resolution (CAR)

A Support process area at Maturity Level 5

Purpose

The purpose of Causal Analysis and Resolution (CAR) is to identify causes of defects and other problems and take action to prevent them from occurring in the future.

Specific Practices by Goal

SG 1 Determine Causes of Defects

SP 1.1-1 Select Defect Data for Analysis

SP 1.2-1 Analyze Causes

SG 2 Address Causes of Defects

SP 2.1-1 Implement the Action Proposals

SP 2.2-1 Evaluate the Effect of Changes

SP 2.3-1 Record Data

Configuration Management (CM)

A Support process area at Maturity Level 2

Purpose

The purpose of Configuration Management (CM) is to establish and maintain the integrity of work products using configuration identification, configuration control, configuration status accounting, and configuration audits.

Specific Practices by Goal

SG 1 Establish Baselines

SP 1.1-1 Identify Configuration Items

SP 1.2-1 Establish a Configuration Management System

SP 1.3-1 Create or Release Baselines

SG 2 Track and Control Changes

SP 2.1-1 Track Change Requests

SP 2.2-1 Control Configuration Items

SG 3 Establish Integrity

SP 3.1-1 Establish Configuration Management Records

SP 3.2-1 Perform Configuration Audits

Decision Analysis and Resolution (DAR)

A Support process area at Maturity Level 3

Purpose

The purpose of Decision Analysis and Resolution (DAR) is to analyze possible decisions using a formal evaluation process that evaluates identified alternatives against established criteria.

Specific Practices by Goal

SG 1 Evaluate Alternatives

SP 1.1-1 Establish Guidelines for Decision Analysis

SP 1.2-1 Establish Evaluation Criteria

SP 1.3-1 Identify Alternative Solutions

SP 1.4-1 Select Evaluation Methods

SP 1.5-1 Evaluate Alternatives

SP 1.6-1 Select Solutions

Integrated Project Management (IPM)

A Project Management process area at Maturity Level 3

Purpose

The purpose of Integrated Project Management (IPM) is to establish and manage the project and the involvement of the relevant stakeholders according to an integrated and defined process that is tailored from the organization's set of standard processes.

Specific Practices by Goal

SG 1 Use the Project's Defined Process

SP 1.1-1 Establish the Project's Defined Process

SP 1.2-1 Use Organizational Process Assets for Planning Project Activities

SP 1.3-1 Integrate Plans

SP 1.4-1 Manage the Project Using the Integrated Plans

SP 1.5-1 Contribute to the Organizational Process Assets

SG 2 Coordinate and Collaborate with Relevant Stakeholders

SP 2.1-1 Manage Stakeholder Involvement

SP 2.2-1 Manage Dependencies

SP 2.3-1 Resolve Coordination Issues

SG 3 Use the Project's Shared Vision for IPPD

SP 3.1-1 Define Project's Shared Vision for IPPD

SP 3.2-1 Establish the Project's Shared Vision

SG 4 Organize Integrated Teams for IPPD

SP 4.1-1 Determine Integrated Team Structure for the Project

SP 4.2-1 Develop a Preliminary Distribution of Requirements to Integrated Teams

SP 4.3-1 Establish Integrated Teams

Integrated Supplier Management (ISM)

A Project Management process area at Maturity Level 3

Purpose

The purpose of Integrated Supplier Management (ISM) is to proactively identify sources of products that may be used to satisfy the project's requirements and to manage selected suppliers while maintaining a cooperative project-supplier relationship.

Specific Practices by Goal

SG 1 Analyze and Select Sources of Products

SP 1.1-1 Analyze Potential Sources of Products

SP 1.2-1 Evaluate and Determine Sources of Products

SG 2 Coordinate Work with Suppliers

SP 2.1-1 Monitor Selected Supplier Processes

SP 2.2-1 Evaluate Selected Supplier Work Products

SP 2.3-1 Revise the Supplier Agreement or Relationship

Integrated Teaming (IT)

A Project Management process area at Maturity Level 3

Purpose

The purpose of Integrated Teaming (IT) is to form and sustain an integrated team for the development of work products.

Specific Practices by Goal

SG 1 Establish Team Composition

SP 1.1-1 Identify Team Tasks

SP 1.2-1 Identify Needed Knowledge and Skills

SP 1.3-1 Assign Appropriate Team Members

SG 2 Govern Team Operation

SP 2.1-1 Establish a Shared Vision

SP 2.2-1 Establish a Team Charter

SP 2.3-1 Define Roles and Responsibilities

SP 2.4-1 Establish Operating Procedures

SP 2.5-1 Collaborate among Interfacing Teams

Measurement and Analysis (MA)

A Support process area at Maturity Level 2

Purpose

The purpose of Measurement and Analysis (MA) is to develop and sustain a measurement capability that is used to support management information needs.

Specific Practices by Goal

SG 1 Align Measurement and Analysis Activities

SP 1.1-1 Establish Measurement Objectives

SP 1.2-1 Specify Measures

SP 1.3-1 Specify Data Collection and Storage Procedures

SP 1.4-1 Specify Analysis Procedures

SG 2 Provide Measurement Results

SP 2.1-1 Collect Measurement Data

SP 2.2-1 Analyze Measurement Data

SP 2.3-1 Store Data and Results

SP 2.4-1 Communicate Results

Organizational Environment for Integration (OEI)

A Support process area at Maturity Level 3

Purpose

The purpose of Organizational Environment for Integration (OEI) is to provide an Integrated Product and Process Development (IPPD) infrastructure and manage people for integration.

Specific Practices by Goal

SG 1 Provide IPPD Infrastructure

SP 1.1-1 Establish the Organization's Shared Vision

SP 1.2-1 Establish an Integrated Work Environment

SP 1.3-1 Identify IPPD-Unique Skill Requirements

SG 2 Manage People for Integration

SP 2.1-1 Establish Leadership Mechanisms

SP 2.2-1 Establish Incentives for Integration

SP 2.3-1 Establish Mechanisms to Balance Team and Home Organization Responsibilities

Organizational Innovation and Deployment (OID)

A Process Management process area at Maturity Level 5

Purpose

The purpose of Organizational Innovation and Deployment (OID) is to select and deploy incremental and innovative improvements that measurably improve the organization's processes and technologies. The improvements support the organization's quality and process-performance objectives as derived from the organization's business objectives.

Specific Practices by Goal

SG 1 Select Improvements

SP 1.1-1 Collect and Analyze Improvement Proposals

SP 1.2-1 Identify and Analyze Innovations

SP 1.3-1 Pilot Improvements

SP 1.4-1 Select Improvements for Deployment

SG 2 Deploy Improvements

SP 2.1-1 Plan the Deployment areas

SP 2.2-1 Manage the Deployment

SP 2.3-1 Measure Improvement Effects

Organizational Process Definition (OPD)

A Process Management process area at Maturity Level 3

Purpose

The purpose of Organizational Process Definition (OPD) is to establish and maintain a usable set of organizational process assets.

Specific Practices by Goal

SG 1 Establish Organizational Process Assets

SP 1.1-1 Establish Standard Processes

SP 1.2-1 Establish Life-Cycle Model Descriptions

SP 1.3-1 Establish Tailoring Criteria and Guidelines

SP 1.4-1 Establish the Organization's Measurement Repository

SP 1.5-1 Establish the Organization's Process Asset Library

Organizational Process Focus (OPF)

A Process Management process area at Maturity Level 3

Purpose

The purpose of Organizational Process Focus (OPF) is to plan and implement organizational process improvement based on a thorough understanding of the current strengths and weaknesses of the organization's processes and process assets.

Specific Practices by Goal

SG 1 Determine Process Improvement Opportunities

SP 1.1-1 Establish Organizational Process Needs

SP 1.2-1 Appraise the Organization's Processes

SP 1.3-1 Identify the Organization's Process Improvements

SG 2 Plan and Implement Process Improvement Activities

SP 2.1-1 Establish Process Action Plans

SP 2.2-1 Implement Process Action Plans

SP 2.3-1 Deploy Organizational Process Assets

SP 2.4-1 Incorporate Process-Related Experiences into the Organizational Process Assets

Organizational Process Performance (OPP)

A Process Management process area at Maturity Level 4

Purpose

The purpose of Organizational Process Performance (OPP) is to establish and maintain a quantitative understanding of the performance of the organization's set of standard processes in support of quality and process-performance objectives, and to provide the process performance data, baselines, and models to quantitatively manage the organization's projects.

Specific Practices by Goal

SG 1 Establish Performance Baselines and Models

SP 1.1-1 Select Processes

SP 1.2-1 Establish Process Performance Measures

SP 1.3-1 Establish Quality and Process Performance Objectives

SP 1.4-1 Establish Process Performance Baselines

SP 1.5-1 Establish Process Performance Models

Organizational Training (OT)

A Process Management process area at Maturity Level 3

Purpose

The purpose of Organizational Training (OT) is to develop the skills and knowledge of people so that they can perform their roles effectively and efficiently.

Specific Practices by Goal

SG 1 Establish an Organizational Training Capability

SP 1.1-1 Establish the Strategic Training Needs

SP 1.2-1 Determine Which Training Needs Are the Responsibility of the Organization

SP 1.3-1 Establish an Organizational Training Tactical Plan

SP 1.4-1 Establish Training Capability

SG 2 Provide Necessary Training

SP 2.1-1 Deliver Training

SP 2.2-1 Establish Training Records

SP 2.3-1 Assess Training Effectiveness

Product Integration (PI)

An Engineering process area at Maturity Level 3

Purpose

The purpose of Product Integration (PI) is to assemble the product from the product components, ensure that the product, as integrated, functions properly and deliver the product.

Specific Practices by Goal

SG 1 Prepare for Product Integration

SP 1.1-1 Determine Integration Sequence

SP 1.2-1 Establish the Product Integration Environment

SP 1.3-1 Establish Product Integration Procedures and Criteria

SG 2 Ensure Interface Compatibility

SP 2.1-1 Review Interface Descriptions for Completeness

SP 2.2-1 Manage Interfaces

SG 3 Assemble Product Components and Deliver the Product

SP 3.1-1 Confirm Readiness of Product Components for Integration

SP 3.2-1 Assemble Product Components

SP 3.3-1 Evaluate Assembled Product Components

SP 3.4-1 Package and Deliver the Product or Product Component

Project Monitoring and Control (PMC)

A Project Management process area at Maturity Level 2

Purpose

The purpose of Project Monitoring and Control (PMC) is to provide an understanding of the project's progress so that appropriate corrective actions can be taken when the project's performance deviates significantly from the plan.

Specific Practices by Goal

sSG 1 Monitor Project Against Plan

SP 1.1-1 Monitor Project Planning Parameters

SP 1.2-1 Monitor Commitments
SP 1.3-1 Monitor Project Risks
SP 1.4-1 Monitor Data Management
SP 1.5-1 Monitor Stakeholder Involvement
SP 1.6-1 Conduct Progress Reviews
SP 1.7-1 Conduct Milestone Reviews
SG 2 Manage Corrective Action to Closure
SP 2.1-1 Analyze Issues
SP 2.2-1 Take Corrective Action
SP 2.3-1 Manage Corrective Action

Project Planning (PP)

A Project Management process area at Maturity Level 2

Purpose

The purpose of Project Planning (PP) is to establish and maintain plans that define project activities.

Specific Practices by Goal

SG 1 Establish Estimates
SP 1.1-1 Estimate the Scope of the Project
SP 1.2-1 Establish Estimates of Work Product and Task Attributes
SP 1.3-1 Define Project Life Cycle
SP 1.4-1 Determine Estimates of Effort and Cost
SG 2 Develop a Project Plan
SP 2.1-1 Establish the Budget and Schedule
SP 2.2-1 Identify Project Risks

SP 2.3-1 Plan for Data Management
SP 2.4-1 Plan for Project Resources
SP 2.5-1 Plan for Needed Knowledge and Skills
SP 2.6-1 Plan Stakeholder Involvement
SP 2.7-1 Establish the Project Plan
SG 3 Obtain Commitment to the Plan
SP 3.1-1 Review Plans that Affect the Project
SP 3.2-1 Reconcile Work and Resource Levels
SP 3.3-1 Obtain Plan Commitment

Process and Product Quality Assurance (PPQA)

A Support process area at Maturity Level 2

Purpose

The purpose of Process and Product Quality Assurance (PPQA) is to provide staff and management with objective insight into processes and associated work products.

Specific Practices by Goal

SG 1 Objectively Evaluate Processes and Work Products

SP 1.1-1 Objectively Evaluate Processes

SP 1.2-1 Objectively Evaluate Work Products and Services

SG 2 Provide Objective Insight

SP 2.1-1 Communicate and Ensure Resolution of Noncompliance Issues

SP 2.2-1 Establish Records

Quantitative Project Management (QPM)

A Project Management process area at Maturity Level 4

Purpose

The purpose of the Quantitative Project Management (QPM) process area is to quantitatively manage the project's defined process to achieve the project's established quality and process-performance objectives.

Specific Practices by Goal

SG 1 Quantitatively Manage the Project

SP 1.1-1 Establish the Project's Objectives

SP 1.2-1 Compose the Defined Processes

SP 1.3-1 Select the Subprocesses that Will Be Statistically Managed

SP 1.4-1 Manage Project Performance

SG 2 Statistically Manage Subprocess Performance

SP 2.1-1 Select Measures and Analytic Techniques

SP 2.2-1 Apply Statistical Methods to Understand Variation

SP 2.3-1 Monitor Performance of the Selected Subprocesses

SP 2.4-1 Record Statistical Management Data

Requirements Development (RD)

An Engineering process area at Maturity Level 3

Purpose

The purpose of Requirements Development (RD) is to produce and analyze customer, product, and product-component requirements.

Specific Practices by Goal

SG 1 Develop Customer Requirements

SP 1.1-1 Collect Stakeholder Needs

SP 1.1-2 Elicit Needs

SP 1.2-1 Develop the Customer Requirements

SG 2 Develop Product Requirements

SP 2.1-1 Establish Product and Product-Component Requirements

SP 2.2-1 Allocate Product-Component Requirements

SP 2.3-1 Identify Interface Requirements

SG 3 Analyze and Validate Requirements

SP 3.1-1 Establish Operational Concepts and Scenarios

SP 3.2-1 Establish a Definition of Required Functionality

SP 3.3-1 Analyze Requirements

SP 3.4-3 Analyze Requirements to Achieve Balance

SP 3.5-1 Validate Requirements

SP 3.5-2 Validate Requirements with Comprehensive Methods

Requirements Management (REQM)

An Engineering process area at Maturity Level 2

Purpose

The purpose of Requirements Management (REQM) is to manage the requirements of the project's products and product components and to identify inconsistencies between those requirements and the project's plans and work products.

Specific Practices by Goal

SG 1 Manage Requirements

SP 1.1-1 Obtain an Understanding of Requirements

SP 1.2-2 Obtain Commitment to Requirements

SP 1.3-1 Manage Requirements Changes

SP 1.4-2 Maintain Bidirectional Traceability of Requirements

SP 1.5-1 Identify Inconsistencies between Project Work and Requirements

Risk Management (RSKM)

A Project Management process area at Maturity Level 3

Purpose

The purpose of Risk Management (RSKM) is to identify potential problems before they occur so that risk-handling activities can be planned and invoked as needed across the life of the product or project to mitigate adverse impacts on achieving objectives.

Specific Practices by Goal

SG 1 Prepare for Risk Management

SP 1.1-1 Determine Risk Sources and Categories

SP 1.2-1 Define Risk Parameters

SP 1.3-1 Establish a Risk Management Strategy

SG 2 Identify and Analyze Risks

SP 2.1-1 Identify Risks

SP 2.2-1 Evaluate, Categorize, and Prioritize Risks

SG 3 Mitigate Risks

SP 3.1-1 Develop Risk Mitigation Plans

SP 3.2-1 Implement Risk Mitigation Plans

Supplier Agreement Management (SAM)

A Project Management process area at Maturity Level 2

Purpose

The purpose of Supplier Agreement Management (SAM) is to manage the acquisition of products from suppliers for which there exists a formal agreement.

Specific Practices by Goal

SG 1 Establish Supplier Agreements

SP 1.1-1 Determine Acquisition Type

SP 1.2-1 Select Suppliers

SP 1.3-1 Establish Supplier Agreements

SG 2 Satisfy Supplier Agreements

SP 2.1-1 Review COTS Products

SP 2.2-1 Execute the Supplier Agreement

SP 2.3-1 Accept the Acquired Product

SP 2.4-1 Transition Products

Technical Solution (TS)

An Engineering process area at Maturity Level 3

Purpose

The purpose of Technical Solution (TS) is to design, develop, and implement solutions to requirements. Solutions, designs, and implementations encompass products, product components, and product-related life-cycle processes either alone or in appropriate combination .

Specific Practices by Goal

SG 1 Select Product-Component Solutions

SP 1.1-1 Develop Alternative Solutions and Selection Criteria

SP 1.1-2 Develop Detailed Alternative Solutions and Selection Criteria

SP 1.2-2 Evolve Operational Concepts and Scenarios

SP 1.3-1 Select Product-Component Solutions

SG 2 Develop the Design

SP 2.1-1 Design the Product or Product Component

SP 2.2-3 Establish a Technical Data Package

SP 2.3-1 Establish Interface Descriptions

SP 2.3-3 Design Interfaces Using Criteria

SP 2.4-3 Perform Make, Buy, or Reuse Analyses

SG 3 Implement the Product Design

SP 3.1-1 Implement the Design

SP 3.2-1 Develop Product Support Documentation

Validation (VAL)

An Engineering process area at Maturity Level 3

Purpose

The purpose of Validation (VAL) is to demonstrate that a product or product component fulfills its intended use when placed in its intended environment.

Specific Practices by Goal

SG 1 Prepare for Validation

SP 1.1-1 Select Products for Validation

SP 1.2-2 Establish the Validation Environment

SP 1.3-3 Establish Validation Procedures and Criteria

SG 2 Validate Product or Product Components

SP 2.1-1 Perform Validation

SP 2.2-1 Analyze Validation Results

Verification (VER)

An Engineering process area at Maturity Level 3

Purpose

The purpose of Verification (VER) is to ensure that selected work products meets their specified requirements.

Specific Practices by Goal

SG 1 Prepare for Verification

SP 1.1-1 Select Work Products for Verification

SP 1.2-2 Establish the Verification Environment

SP 1.3-3 Establish Verification Procedures and Criteria

SG 2 Perform Peer Reviews

SP 2.1-1 Prepare for Peer Reviews

SP 2.2-1 Conduct Peer Reviews

SP 2.3-2 Analyze Peer Review Data

SG 3 Verify Selected Work Products

SP 3.1-1 Perform Verification

SP 3.2-2 Analyze Verification Results and Identify Corrective Action

(A)What is SIX sigma?

Sigma means deviation in Greek language. Deviation means how much variations exist in a set of data. For instance let's say in a software maintenance project out of 100 defects 68 defects are rectified to the mark and remaining bounce back that means your bug fixing process is on "2 Sigma" level. I had described only from bug fixing perspective. But this can be applicable to any process organization.

SIGMA LEVEL	DEFECTS PER MILLION OPPORTUNITIES
1	690,000
2	308,537
3	66,807
4	6,210
5	233
6	3.4

Figure 12.10 : - SIX Sigma Values

So I should only have 3.4 defects in a million defects then I can say I am six sigma.

(A)What is DMAIC and DMADV ?

Six Sigma has two key methodologies DMAIC and DMADV. DMAIC is used to improve an existing business process. DMADV is used to create new product designs or process designs in such a way that it results in a more predictable, mature and defect free performance.

DMAIC

Basic methodology consists of the following five phases:

- √ Define- formally define the process improvement goals that are consistent with customer demands and enterprise strategy.
- √ Measure- to define baseline measurements on current process for future comparison. Map and measure process in question and collect required process data.
- √ Analyze- to verify relationship and causality of factors. What is the relationship? Are there other factors that have not been considered?
- √ Improve - to optimize the process based upon the analysis using techniques like Design of experiments.
- √ Control- setup pilot runs to establish process capability, transition to production and thereafter continuously measure the process and institute control mechanisms to ensure that variances are corrected before they result in defects.

DMADV

Basic methodology consists of the following five phases:

- √ Define- formally define the goals of the design activity that are consistent with customer demands and enterprise strategy.
- √ Measures- to identify CTQs, product capabilities, production process capability, risk assessment, etc.
- √ Analyze-to develop and design alternatives, create high-level design and evaluate design capability to select the best design.
- √ Design- to develop detail design, optimize design, and plan for design verification. This phase may require simulations.

-
- √ Verify-to design, setup pilot runs, implement production process and handover to process owners. This phase may also require simulations.

(A)What are the various roles in Six Sigma implementation?

Attaining Six Sigma is team effort and can not be attained individually. Driving Six Sigma itself in an organization is huge project as it involves lot of mentoring and change of attitude of the current workers. So when an organization wants to drive the Six Sigma way they appoint persons with certain roles as defined below.

Executive Leadership includes CEO and other key top management team members. They are responsible for setting up a vision for Six Sigma implementation. They also empower the other role holders with the freedom and resources to explore new ideas for breakthrough improvements.

Champions are responsible for the Six Sigma implementation across the organization in an integrated manner. The Executive Leadership draw them from the upper management. Champions also act as mentor to Black Belts.

Master Black Belts, identified by champions, act as in-house expert coach for the organization on Six Sigma. They devote 100% of their time to Six Sigma. They assist champions and guide Black Belts and Green Belts. Apart from the usual rigor of statistics, their time is spent on ensuring integrated deployment of Six Sigma across various functions and departments.

Black Belts operate under Master Black Belts to apply Six Sigma methodology to specific projects. They devote 100% of their time to Six Sigma. They primarily focus on Six Sigma project execution, whereas Champions and Master Black Belts focus on identifying projects/functions for Six Sigma.

Green Belts are the employees who take up Six Sigma implementation along with their other job responsibilities. They operate under the guidance of Black Belts and support them in achieving the overall results.

Note: - If you are going for project manager position then you will definitely need to prepare yourself in the area of estimation to a good extent. In the coming sections we will run through estimation related questions which are asked for project manager position. Estimation is a real weakness in software industry today. Different technologies, different company approaches and custom processes followed by software companies it still does not have a standard. So we will try to run through the most embraced estimation technologies by software industry.

(I)What are function points?

Twist: - Define Elementary process in FPA?

FPA is breaking huge systems in to smaller pieces and analyzing them. Software application is combination of set of elementary processes. EP is smallest unit of activity that is meaningful to the user. EP must be self contained and leave the application in a consistent state. Elementary process is not necessarily completely independent or can exist by itself. But it should leave the application in a consistent state.

(I)What are the different types of elementary process in FPA?

There are two types of elementary process

- √ Dynamic Elementary process
- √ Static Elementary process

Dynamic elementary process moves data from internal application boundary to external application boundary or vice-versa.

Examples of dynamic elementary process:

- √ Input data screen where user inputs data in to application. Data moves from the input screen inside application.
- √ Transaction exported in export files in XML or any other standard.
- √ Display reports which can come from external application boundary and internal application boundary.

Static elementary process maintains data of application either inside application boundary or in external application boundary.

Examples of static elementary process:

- √ In a customer maintenance screen maintaining customer data is static elementary process.

(I)What are the different elements in Functions points?

The different elements in function points are as follows:-

-
- √ Internal Logical Files (ILF)
 - √ External Interface File (EIF)
 - √ Record Element Type (RET)
 - √ DET (Data element types)
 - √ File Type Reference (FTR)
 - √ External Input (EI)
 - √ External Inquiry (EQ)
 - √ External Output (EO)

Let's run in detail through each of them.

Internal Logical Files (ILF)

Following are points to be noted for ILF:-

- √ ILF are logically related data from user point of view.
- √ They reside in Internal Application boundary and are maintained through elementary process of application.
- √ ILF may have maintenance screen or probably not.

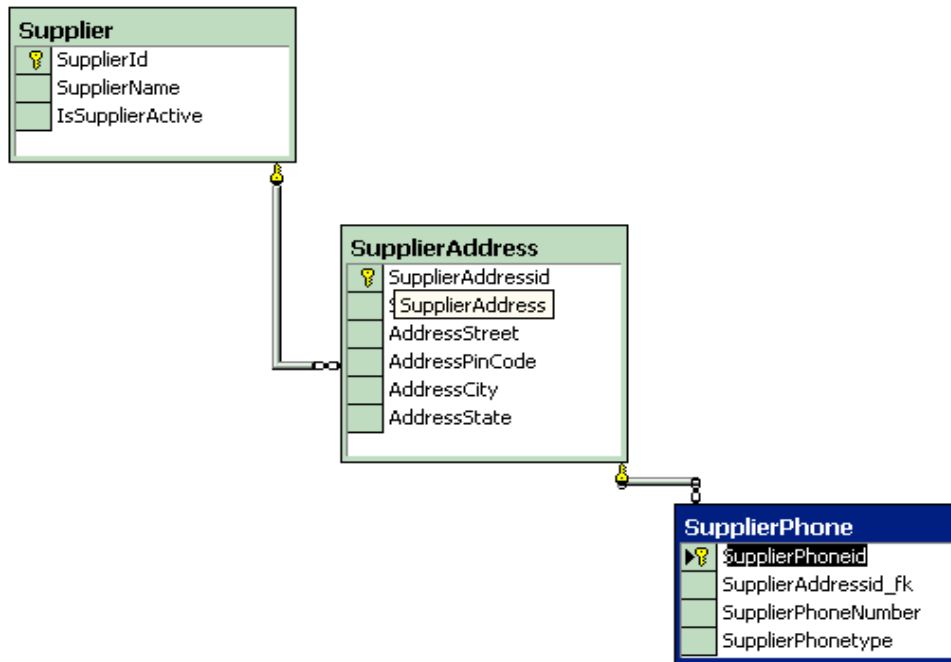

Figure 12.11 : - Supplier ER database diagram

Note: - Do not make a mistake of mapping one to one relationship between ILF and technical database design in that case FPA can go very misleading. The main difference between ILF and technical database is ILF is logical view and database is physical structure (Technical Design). Example Supplier database design will have tables like Supplier, Supplier Address, and Supplier Phone numbers but from ILF point of view it's only Supplier. As logically they are all Supplier details.

External Interface file (EIF)

They are logically related data from user point of view.

- √ EIF reside in external application boundary.
- √ EIF is used only for reference purpose and are not maintained by internal application.
- √ EIF is maintained by external application.

Record Element Type (RET)

Following are points to be noted for RET

- √ RET are sub-group element data of ILF or EIF.
- √ If there is no sub-group of ILF then count the ILF itself as one RET.
- √ A group of RET within ILF are logically related, most probably with a parent Child relationship. Example: - Supplier had multiple addresses and every address can have multiple phone numbers (see the image below which shows database diagrams). So Supplier, SupplierAddress and Supplier phone numbers are RET.

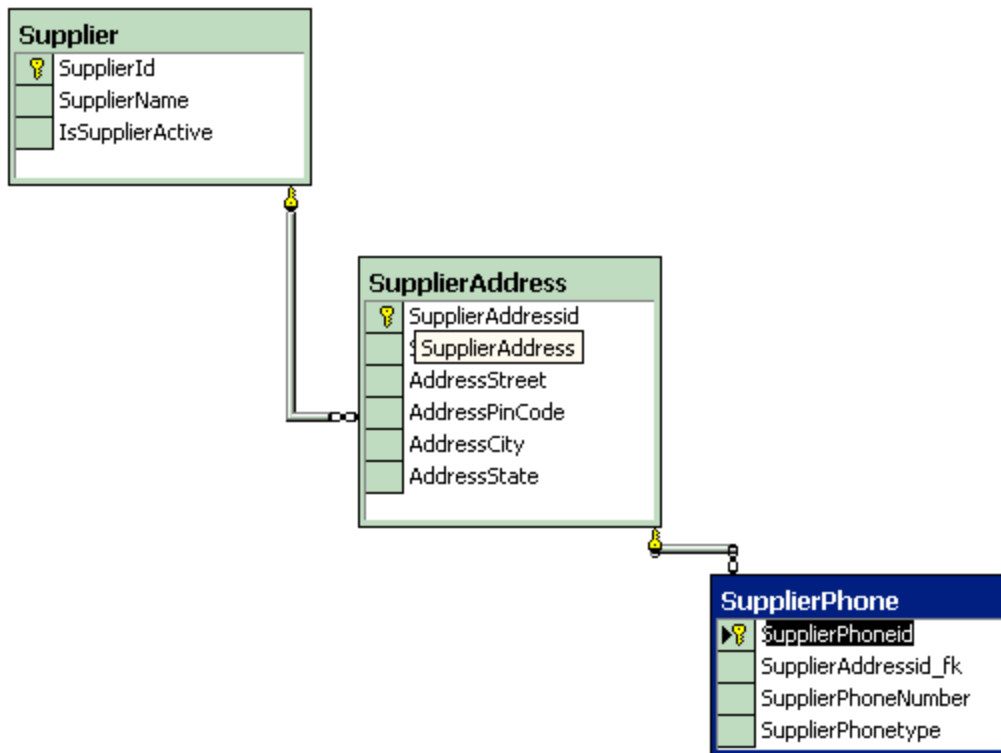

Figure 12.12 : - Whole supplier is one ILF.

Note: - The whole database is one supplier ILF as all belong to one logical section.

-
- √ RET quantifies the relationship complexity of ILF and EIF.

DET (Data element types)

Following are the points to be noted for DET counting:-

- √ Each DET should be User recognizable. Example in the above given figure we have kept auto increment field (Supplierid) for primary key. Supplierid field from user point of view never exists at all, it's only from software designing aspect, so does not qualifies for DET.
- √ DET should be non-recursive field in ILF. DET should not repeat in the same ILF again, it should be counted only once.
- √ Count foreign keys as one DET. "Supplierid" does not qualifies as DET but its relationship in "supplieraddress" table is counted as DET. So "Supplierid_fk" in supplieraddress table is counted as DET. Same holds true for "Supplieraddressid_fk".

File Type Reference (FTR)

Following are points to be noted for FTR:-

- √ FTR is files or data referenced by a transaction.
- √ FTR should be ILF or EIF. So count each ILF or EIF read during process.
- √ If the EP is maintaining an ILF then count that as FTR. So by default you will always have one FTR in any EP.

External Input (EI)

Following are points to be noted for EI:-

- √ It's a dynamic elementary process [For definition see "Dynamic and Static Elementary Process"] in which data is received from external application boundary. Example: - User Interaction Screens, when data comes from User Interface to Internal Application.
- √ EI may maintain ILF of the application, but it is not compulsory rule. Example: - A calculator application does not maintain any data, but still the screen of calculator will be counted as EI.

-
- √ Most of time User Screens will be EI, again no hard and fast rule. Example: - An import batch process running from command line does not have screen, but still should be counted as EI as it helps passing data from External Application Boundary to Internal Application Boundary.

External Inquiry (EQ)

Following are points to be noted for EQ

- √ It's a dynamic elementary process in which result data is retrieved from one or more ILF or EIF.
- √ In this EP some input request has to enter the application boundary.
- √ Output results exits the application boundary.
- √ EQ does not contain any derived data. Derived data means any complex calculated data. Derived data is not just mere retrieval but are combined with additional formulae to generate results. Derived data is not part of ILF or EIF, they are generated on fly.
- √ EQ does not update any ILF or EIF.
- √ EQ activity should be meaningful from user perspective.
- √ EP is self contained and leaves the business in consistent state.
- √ DET and processing logic is different from other EQ's.
- √ Simple reports form good base as EQ.

Note: - No hard and fast rules that only simple reports are EQ. Simple view functionality can also be counted as EQ.

External Output (EO)

Following are points to be noted for EO:-

- √ It's a dynamic elementary process in which derived data crosses from Internal Application Boundary to External Application Boundary.
- √ EO can update an ILF or EIF.
- √ Process should be the smallest unit of activity that is meaningful to end user in business.

-
- √ EP is self contained and leaves the business in a consistent state.
 - √ DET is different from other EO's. So this ensures to us that we do not count EO's twice.
 - √ They have derived data or formulae calculated data.
 - √ Major difference between EO and EQ is that data passes across application boundary. Example: - Exporting Accounts transaction to some external file format like XML or some other format. This can be later imported by the external accounting software. Second important difference is in EQ has non-derived data and EO has derived data.

(A) Can you explain in GSC and VAF in function points?

In GSC (General System Characteristic) there are 14 factors which are rated on 1 to 5 depending on the complexity of the factor. Below are the 14 factors:-

- √ Data communications: - How many communication facilities are there to aid in the transfer or exchange of information with the application or system?
- √ Distributed data processing: - How are distributed data and processing functions handled?
- √ Performance: - Did the user require response at times or throughout?
- √ Heavily used configuration: - How heavily used is the current hardware platform where the application will be executed?
- √ Transaction rate:-How frequently are transactions executed; daily, weekly, monthly, etc.?
- √ On-Line data entry:-What percentage of the information is entered On-Line?
- √ End-user efficiency:-Was the application designed for end-user efficiency?
- √ On-Line update: - How many ILF's are updated by On-Line transaction?
- √ Complex processing:-Does the application have extensive logical or mathematical processing?.
- √ Reusability:-Was the application developed to meet one or many users needs?
- √ Installation ease: - How difficult is conversion and installation?

- √ Operational ease: - How effective and/or automated are start-up, back up, and recovery procedures?
- √ Multiple sites: - Was the application specifically designed, developed, and supported to be installed at multiple sites for multiple organizations?
- √ Facilitate change: - Was the application specifically designed, developed, and supported to facilitate change?

Performance	throughput?	5
Heavily used configuration	How heavily used is the current hardware platform where the application will be executed?	1
Transaction rate	How frequently are transactions executed; daily, weekly, monthly, etc.?	5
On-Line data entry	What percentage of the information is entered On-Line?	5
End-user efficiency	Was the application designed for end-user efficiency?	1
On-Line update	How many ILF's are updated by On-Line transaction?	5
Complex processing	Does the application have extensive logical or mathematical processing?	5
Reusability	Was the application developed to meet one or many user's needs?	5
Installation ease	How difficult is conversion and installation?	5
Operational ease	How effective and/or automated are start-up, back up, and recovery procedures?	5
Multiple sites	Was the application specifically designed, developed, and supported to be installed at multiple sites for multiple organizations?	5
Facilitate change	Was the application specifically designed, developed, and supported to facilitate change?	5
GSC		1.23

Figure 12.13 : - GSC rated in estimation sheet

From the GSC we get the VAF i.e. Value added function points by the below formulae.

$$VAF = 0.65 + ((\text{sum of all GSC factor})/100).$$

(I)What are unadjusted function points and how is it calculated?

Unadjusted function points = ILF + EIF + EI + EQ + EO.

Below is the table referred for getting ILF, EIF, EI, EQ and EO.

EI Rating Table			
	Data Elements		
FTR	1 to 4	5 to 15	> 15
Less than 2	3	3	4
Equal to 2	3	4	6
Greater than 2	4	6	6

EO Rating Table			
	Data Elements		
FTR	1 to 5	6 to 19	> 19
Less than 2	4	4	5
2 or 3	4	5	7
Greater than 2	5	7	7

EQ Rating Table			
	Data Elements		
FTR	1 to 5	6 to 19	> 19
Less than 2	3	3	4
2 or 3	3	4	6
Greater than 2	4	6	6

ILF Rating Table			
	Data Elements		
RET	1 to 19	20 to 50	>= 51
1	7	7	10
2 to 5	7	10	15
Greater than 6	10	15	15

EIF Rating Table			
	Data Elements		
RET	1 to 19	20 to 50	>= 51
1	5	5	7
2 to 5	5	7	10
Greater than 6	7	10	10

Figure 12.14 : - Rating tables

(I)Can you explain steps in function points?

Below are the steps in function points:-

- √ First Count ILF, EIF, EI, EQ, RET, DET, FTR and use the rating tables. After you have counted all the elements you will get the unadjusted function points.
- √ Put rating values 0 to 5 to all 14 GSC. Adding total of all 14 GSC to come out with total VAF. Formula for VAF = $0.65 + (\text{sum of all GSC factor}/100)$.
- √ Finally, make the calculation of adjusted function point. Formula: Total function point = VAF * Unadjusted function point.
- √ Make estimation how many function points you will do per day. This is also called as "Performance factor".
- √ On basis of performance factor, you can calculate Man/Days.

(I) What is the FP per day in your current company?

Twist :- What is your company's productivity factor ?

Left to the readers as every company has his own FP per Day.

Note: - There is a free PDF provided "How to prepare Software Quotations?" Please do refer Function point chapter.

(A)Do you know Use Case points?

In CD we have a complete free PDF tutorial of how to prepare software quotation. It has all the estimation technology that today's software industry uses.

(A)What is COCOMO I, COCOMOII and COCOMOIII?

In CD we have a complete free PDF tutorial of how to prepare software quotation. It has all the estimation technology that today's software industry uses.

(A) What is SMC approach of estimation?

Look for the PDF in the CD.

(A)How do you estimate maintenance project and change requests?

Left for the readers to answer.

13 . XML

Note: - In this chapter we will first just skim through basic XML interview questions so that you do not get stuck up with simple questions.

(B)What is XML?

XML (Extensible markup language) is all about describing data. Below is a XML which describes invoice data.

```
<?xml version="1.0" encoding="ISO-8859-1"?>
<invoice>
<productname>Shoes</productname>
<qty>12</qty>
<totalcost>100</totalcost>
<discount>10</discount>
</invoice>
```

An XML tag is not something predefined but it is something you have to define according to your needs. For instance in the above example of invoice all tags are defined according to business needs. The XML document is self explanatory, any one can easily understand looking at the XML data what exactly it means.

(I)What is the version information in XML?

“version” tag shows which version of XML is used.

(B)What is ROOT element in XML?

In our XML sample given previously <invoice></invoice> tag is the root element. Root element is the top most elements for a XML.

(B)If XML does not have closing tag will it work?

No, every tag in XML which is opened should have a closing tag. For instance in the top if I remove </discount> tag that XML will not be understood by lot of application.

(B)Is XML case sensitive?

Yes, they are case sensitive.

(B)What is the difference between XML and HTML?

XML describes data while HTML describes how the data should be displayed. So HTML is about displaying information while XML is about describing information.

(B)Is XML meant to replace HTML?

No, they both go together one is for describing data while other is for displaying data.

(A)Can you explain why your project needed XML?

Note: - This is an interview question where the interviewer wants to know why you have chosen XML.

Remember XML was meant to exchange data between two entities as you can define your user friendly tags with ease. In real world scenarios XML is meant to exchange data. For instance you have two applications who want to exchange information. But because they work in two complete opposite technologies it's difficult to do it technically. For instance one application is made in JAVA and the other in .NET. But both languages understand XML so one of the applications will spit XML file which will be consumed and parsed by other applications

You can give a scenario of two applications which are working separately and how you chose XML as the data transport medium.

(B)What is DTD (Document Type definition)?

It defines how your XML should structure. For instance in the above XML we want to make it compulsory to provide "qty" and "totalcost", also that these two elements can only contain numeric. So you can define the DTD document and use that DTD document with in that XML.

(B)What is well formed XML?

If a XML document is confirming to XML rules (all tags started are closed, there is a root element etc) then it's a well formed XML.

(B)What is a valid XML?

If XML is confirming to DTD rules then it's a valid XML.

(B)What is CDATA section in XML?

All data is normally parsed in XML but if you want to exclude some elements you will need to put those elements in CDATA.

(B)What is CSS?

With CSS you can format a XML document.

(B)What is XSL?

XSL (the eXtensible Stylesheet Language) is used to transform XML document to some other document. So its transformation document which can convert XML to some other document. For instance you can apply XSL to XML and convert it to HTML document or probably CSV files.

(B)What is element and attributes in XML?

In the below example invoice is the element and the invnumber the attribute.

```
<invoice invnumber=1002></invoice>
```

(B)Which are the namespaces in .NET used for XML?

“System.xml.dll” is the actual physical file which has all XML implementation. Below are the commonly used namespaces:-

- √ System.Xml
- √ System.Xml.Schema
- √ System.Xml.XPath
- √ System.Xml.Xsl

(A)What are the standard ways of parsing XML document?

Twist: - What is a XML parser?

XML parser sits in between the XML document and the application who want to use the XML document. Parser exposes set of well defined interfaces which can be used by the application for adding, modifying and deleting the XML document contents. Now whatever interfaces XML parser exposes should be standard or else that would lead to different vendors preparing there own custom way of interacting with XML document.

There are two standard specifications which are very common and should be followed by a XML parser:-

DOM: - Document Object Model.

DOM is a W3C recommended way for treating XML documents. In DOM we load entire XML document into memory and allows us to manipulate the structure and data of XML document.

SAX: - Simple API for XML.

SAX is event driven way for processing XML documents. In DOM we load the whole XML document in to memory and then application manipulates the XML document. But this is not always the best way to process large XML documents which have huge data elements. For instance you only want one element from the whole XML document or you only want to see if the XML is proper which means loading the whole XML in memory will be quiet resource intensive. SAX parsers parse the XML document sequentially and emit events like start and end of the document, elements, text content etc. So applications who are interested in processing these events can register implementations of callback interfaces. SAX parser then only sends those event messages which the application has demanded.

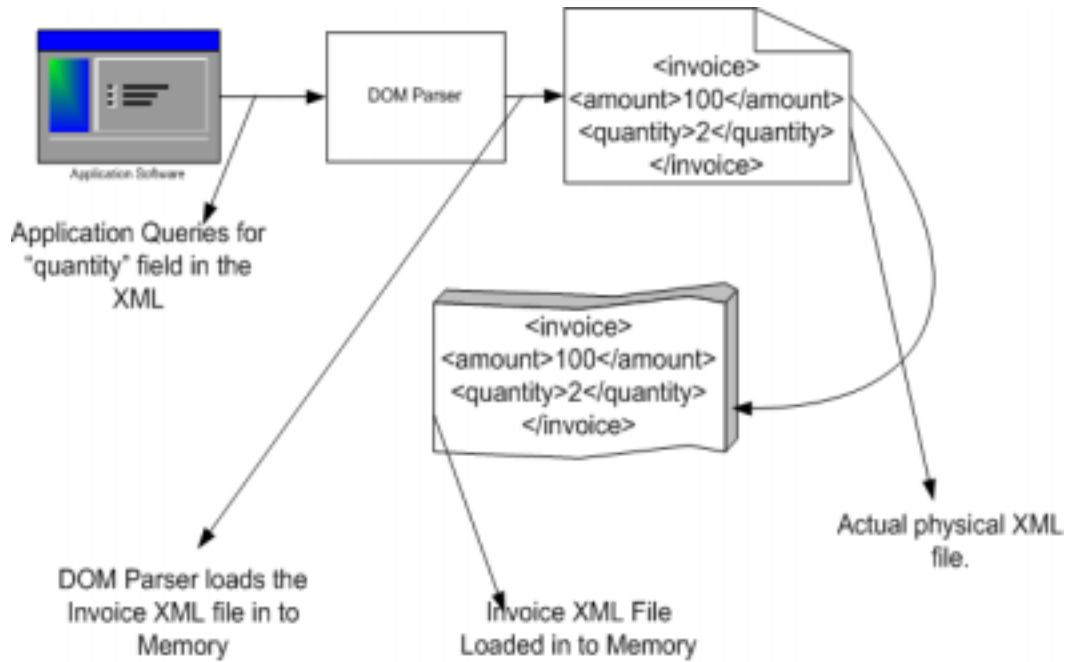

Figure 13.1 : - DOM Parser loading XML document

Above is a pictorial representation of how DOM parser works. Application queries the DOM Parser for “quantity” field. DOM parser loads the complete XML file in to memory.

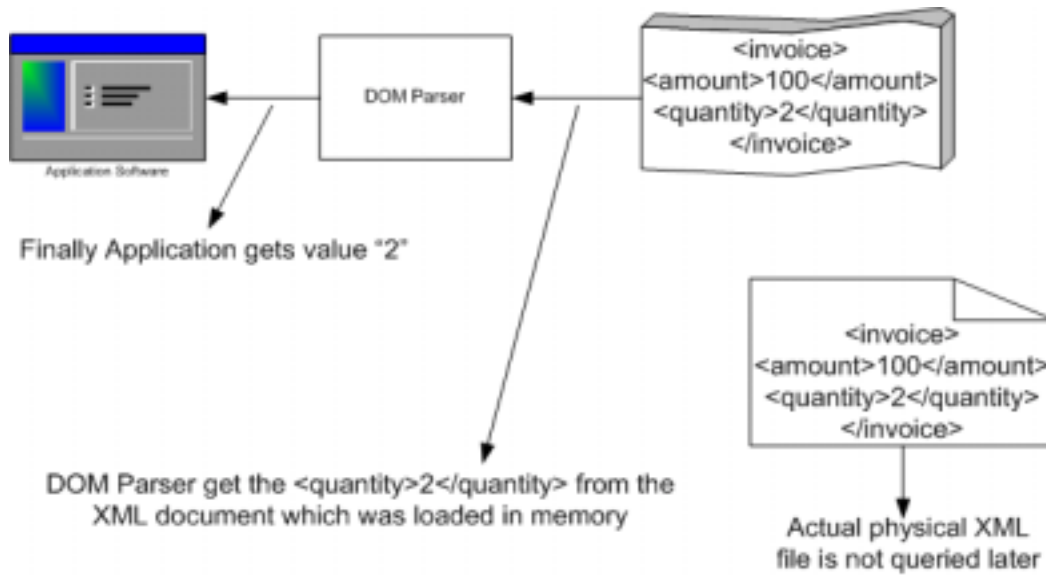

Figure 13.2 : - Returning the Quantity value back to application

DOM parser then picks up the “quantity” tag from the memory loaded XML file and returns back to the application.

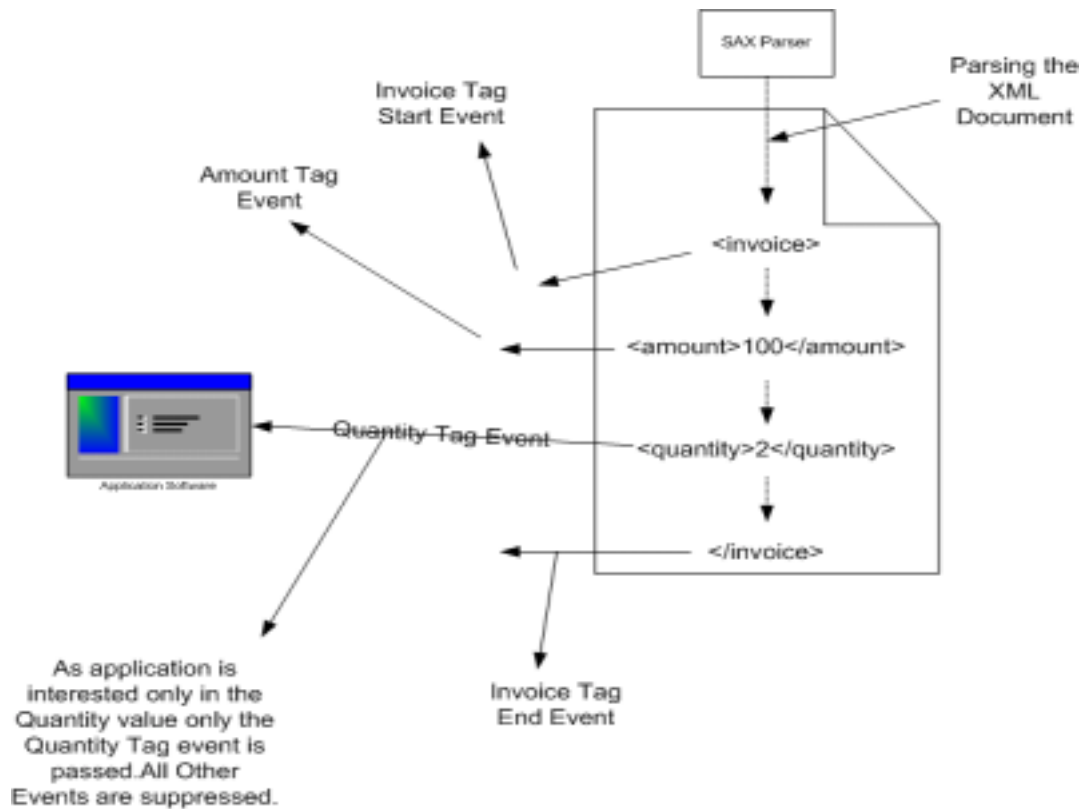

Figure 13.3 : - SAX parser in action

SAX parser does not load the whole DOM in to memory but has event based approach. SAX parser while parsing the XML file emits events. For example in the above figure its has emitted Invoice tag start event, Amount Tag event, Quantity tag event and Invoice end tag event. But our application software is only interested in quantity value. So the application has to register to the SAX parser saying that he is only interested in quantity field and not any other field or element of the XML document. Depending on what interest the application software has SAX parser only sends those events to the application the rest of events is suppressed. For instance in the above figure only quantity tag event is sent to the application software and the rest of the events are suppressed.

(A) In What scenarios will you use a DOM parser and SAX parser?

- √ If you do not need all the data from the XML file then SAX approach is much preferred than DOM as DOM can quiet memory intensive. In short if you need large portion of the XML document its better to have DOM.
- √ With SAX parser you have to write more code than DOM.
- √ If you want to write the XML in to a file DOM is the efficient way to do it.
- √ Some time you only need to validate the XML structure and do not want to retrieve any Data for those instances SAX is the right approach.

(A) How was XML handled during COM times?

During COM it was done by using MSXML 4.0. So old languages like VB6, VC++ used MSXML 4.0 which was shipped with SP1(Service Pack 1).

Note: - This book will not show any samples as such for MSXML 4.0. So if anyone interested please do refer the same in MSDN and try to compile some sample programs.

(A) What is the main difference between MSML and .NET Framework XML classes?

MSXML supports XMLDOM and SAX parsers while .NET framework XML classes support XML DOM and XML readers and writers.

MSXML supports asynchronous loading and validation while parsing. For instance you can send synchronous and asynchronous calls to a remote URL. But as such there is not direct support of synchronous and asynchronous calls in .NET framework XML. But same can be achieved by using “System.Net” namespaces.

(B) What are the core functionalities in XML .NET framework? Can you explain in detail those functionalities?

The XML API for the .NET Framework comprises the following set of functionalities:

XML readers

With XML readers the client application get reference to instance of reader class. Reader class allows you to scroll forward through the contents like moving from node to node or element to element. You can compare it with the “SqlDataReader” object in ADO.NET which is forward only. In short XML reader allows you to browse through the XML document.

XML writers

Using XML writers you can store the XML contents to any other storage media. For instance you want to store the whole in memory XML to a physical file or any other media.

XML document classes

XML documents provides a in memory representation for the data in an XMLDOM structure as defined by W3C. It also supports browsing and editing of the document. So it gives you a complete memory tree structure representation of your XML document.

(B)What is XSLT?

XSLT is a rule based language used to transform XML documents in to other file formats. XSLT are nothing but generic transformation rules which can be applied to transform XML document to HTML, CS, Rich text etc.

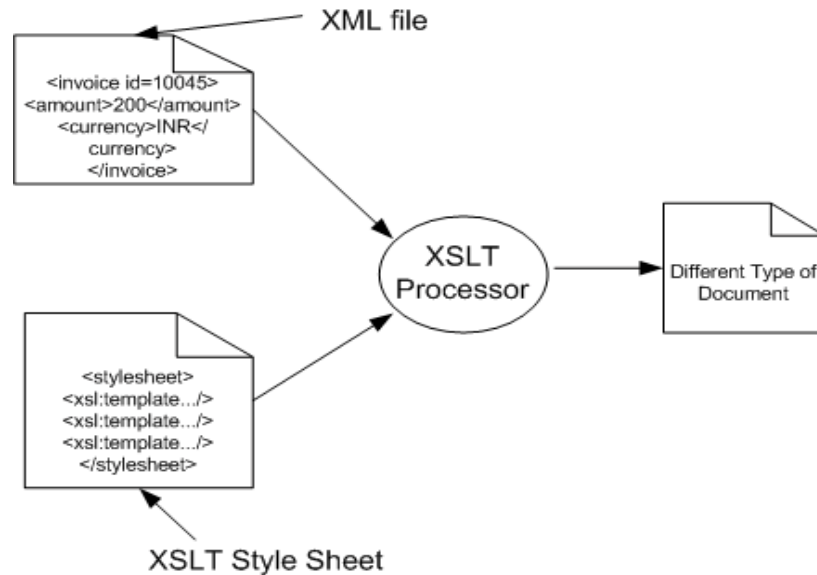

Figure 13.4 : - XSLT Processor in Actions

You can see in the above figure how the XSLT processor takes the XML file and applies the XSLT transformation to produce a different document.

(I) Define XPATH?

It is an XML query language to select specific parts of an XML document. Using XPATH you can address or filter elements and text in a XML document. For instance a simple XPATH expression like “Invoice/Amount” states find “Amount” node which are children of “Invoice” node.

(A) What is the concept of XPOINTER?

XPOINTER is used to locate data within XML document. XPOINTER can point to a particular portion of a XML document, for instance

address.xml#xpointer(/descendant::streetnumber[@id=9])

So the above XPOINTER points streetnumber=9 in “address.xml”.

(B)What is an XMLReader Class?

It is an abstract class available from System.XML namespace. XML reader works on a read-only stream browsing from one node to other in a forward direction. It maintains only a pointer to the current node but has no idea of the previous and the next node. You can not modify the XML document, you can only move forward.

(B)What is XMLTextReader?

The “XmlTextReader” class helps to provide fast access to streams of XML data in a forward-only and read-only manner. It also checks if the XML is well-formed. But XMLTextReader does not validate against a schema or DTD for that you will need “XmlNodeReader” or “XmlValidatingReader” class.

Instance of “XmlTextReader” can be created in number of ways. For example if you want to load file from a disk you can use the below snippets.

```
XmlTextReader reader = new XmlTextReader(fileName);
```

To loop through all the nodes you need to call the “read()” method of the “XmlTextreader” object. “read()” method returns “true” if there are records in the XML document or else it returns “false”.

```
//Open the stream  
XmlTextReader reader = new XmlTextReader(file);  
while (reader.Read())  
{  
// your logic goes here  
string pdata = reader.Value  
}  
// Close the stream  
reader.Close();
```

To read the content of the current node on which the reader object is you use the “value” property. As shown in the above code “pdata” gets the value from the XML using “reader.value”.

(I)How do we access attributes using “XmlReader”?

Below snippets shows the way to access attributes. First in order to check whether there any attributes present in the current node you can use “HasAttributes” function and use the “MoveToNextAttribute” method to move forward in attribute. In case you want to move to the next element use “MoveToElement()”.

```
if (reader.HasAttributes)
{
while(reader.MoveToNextAttribute())
{
// your logic goes here
string pdata = reader.Value
}
}

reader.MoveToElement();
```

(I) Explain simple Walk through of XmlReader ?

In this section we will do a simple walkthrough of how to use the “XmlReader” class. Sample for the same is available in both languages (C# and VB.NET) which you can find in “WindowsApplicationXMLVBNET” and “WindowsApplicationCSharp” folders. Task is to load “TestingXML.XML” file and display its data in a message box. You can find “TestingXML.XML” file in “BIN” directory of both the folders. Below is the display of “TestingXML.XML” file and its content.

```
<invoice id="100">
<amount>200</amount>
<currency>Rupees</currency>
<productname>Interview Question Series</productname>
<authorname>Shivprasad Koirala</authorname>
</invoice>
```

Figure 13.5 : - Testing.XML Data

Both the projects have command button “CmdLoadXML” which has the logic to load the XML file and display the data in messagebox. I have pasted only the “CmdLoadXML” command button logic for simplicity. Following are the basic steps done:-

- √ Declared the “XMLTextReader” object and gave the XML filename to load the XML data.
- √ Read the “XMLTextReader” object until it has data and concatenate the data in a temporary string.
- √ Finally display the same in a message box.

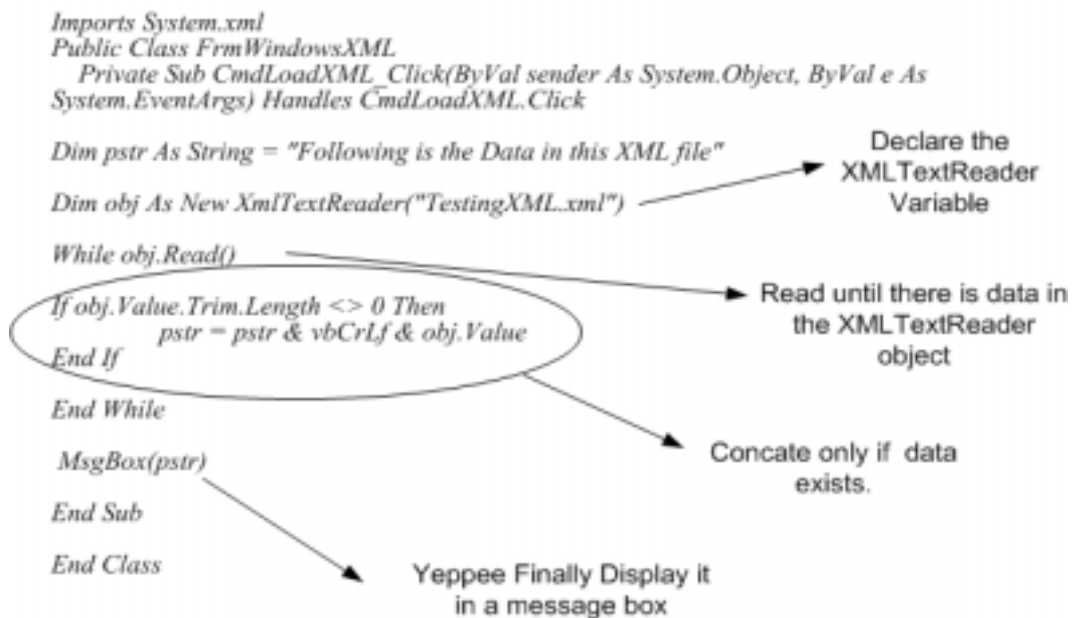

Figure 13.6 : - VB.NET code for XMLReader

Same holds true for C# code as shown below.

```

private void cmdLoadXml_Click(object sender, EventArgs e)
{
    XmlTextReader objxmltextreader = new XmlTextReader("TestingXML.XML");
    string pstr;
    pstr = "Data in this XML";
    while (objxmltextreader.Read())
    {
        if (objxmltextreader.Value.Trim().Length != 0)
        {
            pstr = pstr + '\n' + objxmltextreader.Value;
        }
    }
    MessageBox.Show(pstr);
}
}

```

→ Declare the XmlTextReader Variable
 → Read until there is data in the XmlTextReader object
 → Concatate only if data exists.
 → Yeppee Finally Display it in a message box

Figure 13.7 : - C# code for XMLReader

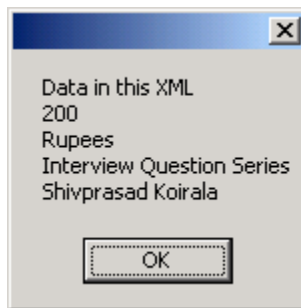

Figure 13.8 : - Data Display for "TestingXML.XML"

(A) What does XmlValidatingReader class do?

XmlTextReader class does not validate the contents of an XML source against a schema. The correctness of XML documents can be measured by two things is the document well formed and is it valid. Well-formed means that the overall syntax is correct. Validation is much deeper which means is the XML document is proper w.r.t schema defined.

So the XmlTextReader only checks if the syntax is correct but does not do validation. There's where XmlValidatingReader class comes in to picture. So this again comes at a price as XmlValidatingReader have to check for DTD and Schema's there are slower compared to XmlTextReader.

14. Localization/Globalization

(B)What is Unicode and why was it introduced?

Note: - This moment is special to me. While sipping tea in morning I received this email from one of my readers.

“I should say your book has everything in the world which a .NET person will need. I am a fresher from Hyderabad. In eight months my sister has to be operated. For that I should get a job some how in 2 weeks so that I am eligible for a loan after 6 months. That’s when I came across your book. I Read it again, and again from top to bottom. LOL got a job in 2 weeks. Thanks for saving my sister and making me a proud brother”.

Reading this email has made me really fresh, more than what my morning tea can give me. Mail me your job search success and struggles to shiv_koirala@yahoo.com.

In order to understand the concept of Unicode we need to move little back and understand ANSI code. ASCII (ask key) stands for American Standard Code for Information Interchange. In ASCII format every character is represented by one byte (i.e. 8 bits). So in short we can have 256 characters (2^8). Before UNICODE came in to picture programmers used code page to represent characters in different languages. Code page is a different interpretation of ASCII set. Code pages keep 128 characters for English and the rest 128 characters are tailored for a specific language.

Below is a pictorial representation of the same.

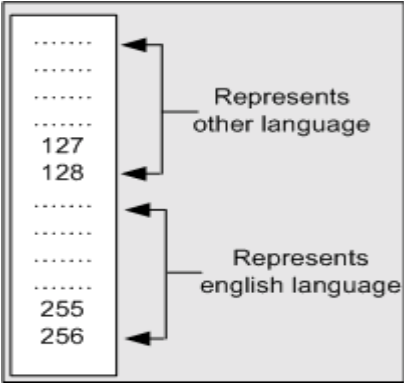

Figure 14.1 :- Code page in action

There are following disadvantages of the CODE page approach:-

- √ Some languages like Chinese have more than 5000 characters which is difficult to represent only 128 character set.
- √ Only two languages can be supported at one time. As said in the previous note you can use 128 for English and the rest 128 for the other language.
- √ The end client should have the code page.
- √ Code Representation change according to Operating system and Language used. That means a character can be represented in different numbers depending on operating system.

For all the above problems UNICODE was introduced. UNICODE represents characters with 2 bytes. So if its two bytes that means 16 bits. You can now have 2^{16} characters i.e. 65536 characters. That's a huge number you can include any language in the world. Further if you use surrogates you can have additional 1 million characters...Hmm that can include type of language including historian characters.

ASCII representation varied according to operating system and language. But in UNICODE it assigns a unique letter for every character irrespective of Language or operating system which makes programmers life much easier while developing international compatible applications.

(I)Does .NET support UNICODE and how do you know it supports?

Yes .NET definitely supports UNICODE. Try to see `sizeof (char)`, you will see 2 bytes. Char type data type stores only one character which needs only 8 bits but because .NET has to support UNICODE it uses 16 bits to store the same.

(A)What's the difference between localization and globalization?

Below are the definition's which is taken from the Microsoft glossary.

Globalization: It is the process of developing a program core whose features and code design are not solely based on a single language or locale.

Localization: The process of adapting a program for a specific local market, which includes translating the user interface, resizing dialog boxes, customizing features (if necessary), and testing results to ensure that the program still works.

You can visualize globalization as more of architecture decisions. While localization is adapting your content to local market. Localization phase occurs before globalization phase.

(A)What architecture decisions you should consider while planning for international software's?

Note: - Many programmers think its only converting the text from one language to other. It's a very wrong assumption that just by translating strings from one language to other language the software is localized. Interviewer will definitely get disappointed by such an answer. So let's try to visualize what are the design considerations to be taken when we design software globally.

- √ Avoid hard coding of strings in the project. Any display right from labels to error messages read it from a resource file.
- √ Length of the string is also of prime importance. It's a noted fact that when we translate English language in to other language the words increase by minimum 30 to 40 %. For instance you can see from the below figure how the Hindi text has increased as compared to English text.

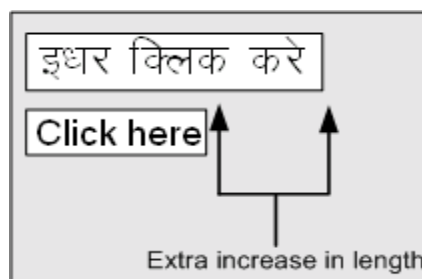

Figure 14.2 : - Text length increase

So all your labels, message boxes have to be designed in such a way that this text size mismatch is adjusted. Do not crowd all your fields on one screen you will definitely end with the text length issue. Leave some room for expansion.

- √ Decimal separator varies from locale to locale. For instance 25, 12.80 in the United States is 25.12,80 in Greece or Germany. Yes you guessed right the decimal separator in Europe is a "," (Comma).
- √ Calendar changes from country to country. Definitely Gregorian calendar is the most used. But there are some other calendars like Hebrew, Islamic, Chinese etc. All these calendars have huge differences. For instance Nepal follows Nepali Calendar which is 56.7 years ahead of Gregorian calendar. So according to cultural settings user can expect the dates accordingly.
- √ Sort order is affected by language. You can see from the figure below Hindi and English languages have different sorting order.

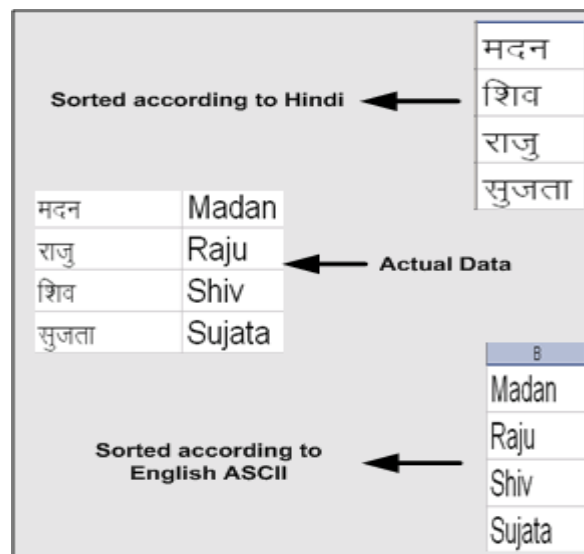

Figure 14.3 : - Different sorting order according to locale

- √ Time varies from locale to locale. For instance an 8 PM in India is 20:00 in Europe. In Europe there is not concept of AM and PM.

- √ If you are using built-in fonts use the resource file to bundle the same. You can load the fonts from the resource file rather than telling the user explicitly to install the fonts in his PC.
- √ Keyboards layout changes according locale and region. So be careful while designing the short cut keys. The function keys are mostly present in all key boards. Probably you can consider the function keys for short cut keys. Below is a sample Hindi key board. If you define CTRL + V as a short cut for paste functionality it can create confusion for Hindi users on the below key board.

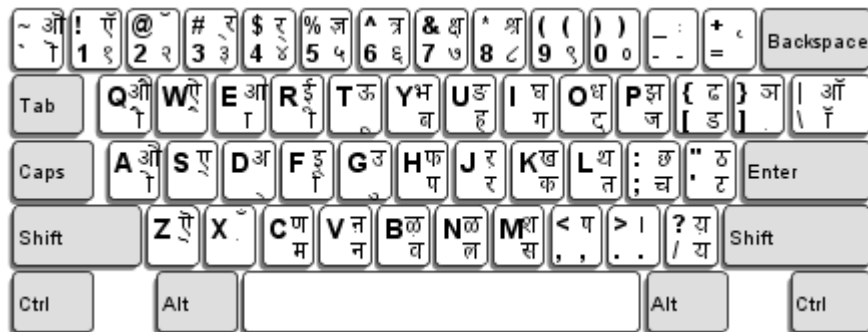

Figure 14.4 : - Localized Hindi keyboard

Courtesy: - Image taken from <http://www-306.ibm.com/>

So you can see from the above points that making software adapt to global culture is not only related to string translation. It's much beyond that.

(I) How do we get the current culture of the environment in windows and ASP.NET?

“CultureInfo.CurrentCulture” displays the current culture of the environment. For instance if you are running Hindi it will display “hi-IN”. Please note one thing in mind “CurrentCulture” will only give you the culture on which your application is running. So if it's a windows application this will work fine. But in ASP.NET 2.0 we need to know what culture the end user has.

For a real international website different users can log in with different culture. For instance you can see from the given figure below different users are logging in with different

regional settings. Client browser sends the information in the request headers to the server. For instance a Korean user will send “KO” in the request headers to server. We can get the value using the” Request.UserLanguages”.

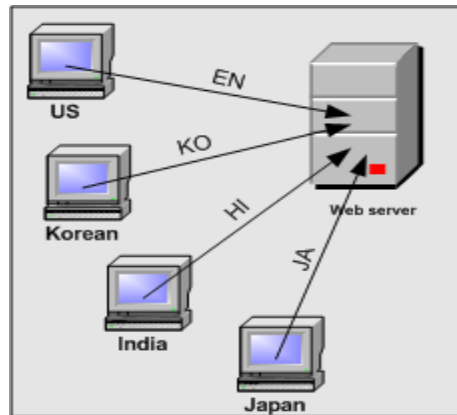

Figure 14.5 : - Different users logging in from different countries

Regional settings are defined on the user’s browser as shown below. Click on Tools – Internet options – Languages. You can then add languages in the language preference box. Using "Move up" and "Move down" you can define the priority of the languages. In the below figure we have four languages defined with “Hindi” language set at the top priority. ” Request.UserLanguages” returns back an array of string with the sorted order defined in your language preference tab of the browser.

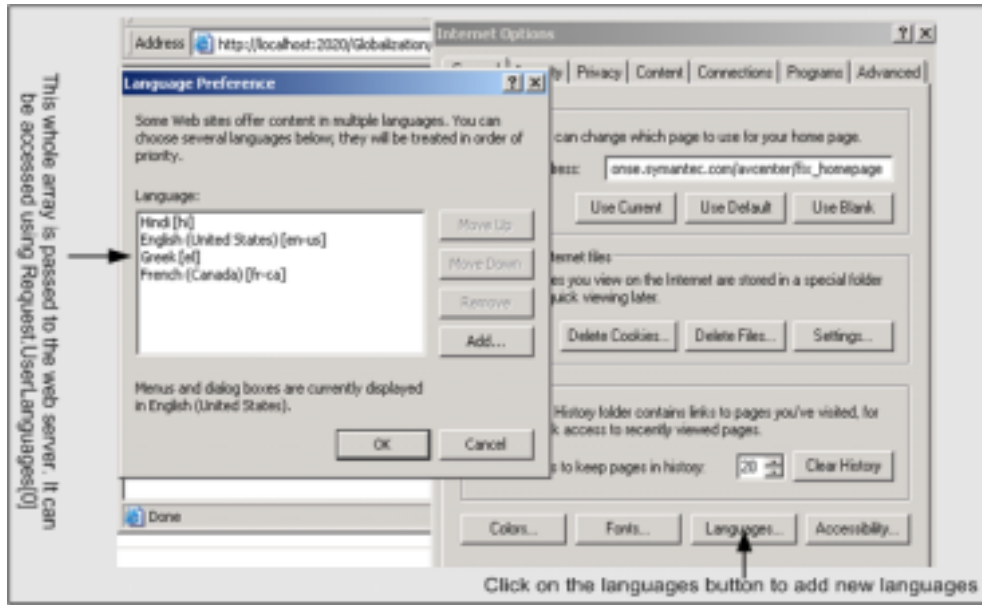

Figure 14.6 : - Setting language preferences in browser

Below is the code snippet which shows how we can display the user languages. The first figure is the code snippet which shows how to use “Request.UserLanguages”. The second figure shows the output for the same.

```
protected void Page_Load(object sender, EventArgs e)
{
    foreach(string strLang in Request.UserLanguages)
    {
        Response.Write(strLang + "<br>");
    }
}
```

This will return a array of languages supported by the end browser.

Figure 14.7 : - Request.UserLangauges in action

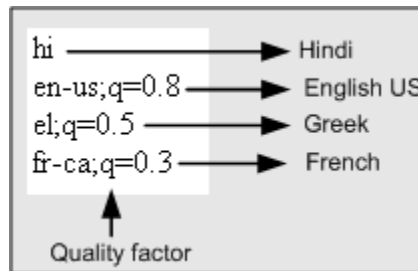

Figure 14.8 : - Output from request.Userlanguages

One of the things to be noted is “q” value. “q” stands for quality factor. In the above figure the quality factor means the following:-

"I prefer Hindi, but will accept English US (with 80% comprehension) or Greek (with 50% comprehension) or French (with 30 % comprehension)."

Just for Non-English speakers meaning of Comprehension.

It is the process of understanding and constructing meaning from a piece of text.

The comprehension is from the perspective of the end user. It says the end browser user will understand with this much comprehension for that language. For instance in the above example the end browser under stands English comprehension of 80 %.

Note: - You can find the sample to display the user languages in “Globalization” folder. Run “DisplayAllLanguageSettings.aspx” and see the output. Just to mention the source is coded in VS.NET 2005 so if you try to open it using VS.NET 2003 you can get errors.

(B) Which are the important namespaces during localization and globalization?

There are two most important namespaces:-

- √ System.Globalization - contains classes that define culture-related information, including the language, the country/region, the calendars in use, the format patterns for dates, currency and numbers, and the sort order for strings.
- √ System.Resources - provides classes and interfaces that allow developers to create, store, and manage various culture-specific resources used in an application. With

this namespace you can read a resource file and display it accordingly to the user's culture.

(B)What are resource files and how do we generate resource files?

Resource files are files which contain program resources. Many programmers think resource files for only storing strings. But you can also store bitmaps, icons, fonts, wav files in to resource files.

In order to generate resource file you need click on tools – generate local resource as shown in the figure below. Do not forget to keep page in designer view or else you will not see the option. Once you generate the resource file you will see the resx file generated in the solution explorer.

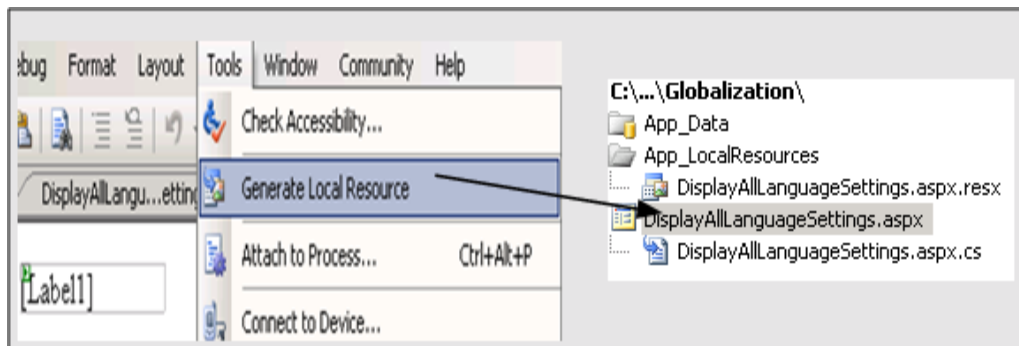

Figure 14.9 : - Generating resource files using IDE

If you see the resource file it has basically key and the value for the key.

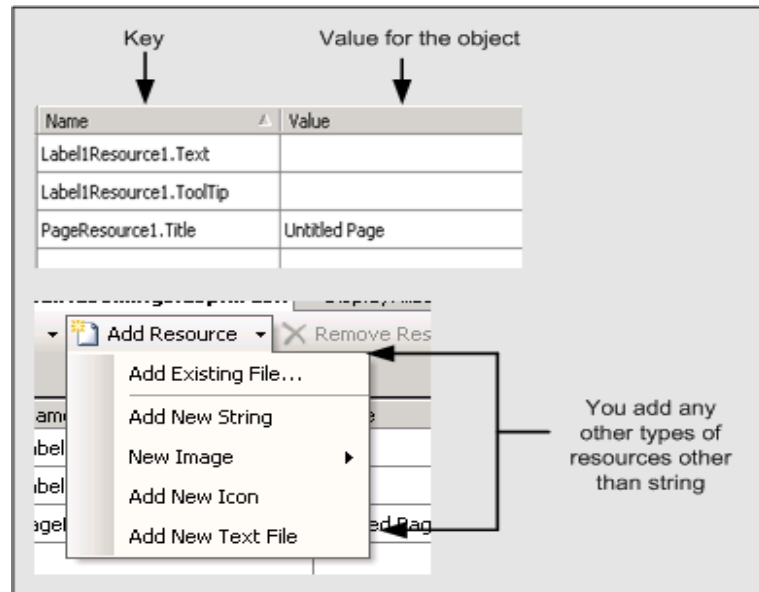

Figure 14.10 : - Resource file in action

If you see the above figure the key is basically the object name. You can see the Label1 has some value stored in the resource file.

(I) Can resource file be in any other format other than resx extensions?

Yes they can be in .txt format in name and value pairs. For instance below is a simple .txt file with values.

lblUserId = User Id

lblPassword = Password

cmdSubmitPassword = Submit

(I)How is resource files actually used in project?

(A)How can we use Culture Auto in project?

Note: - Hmmm we have talked so much theoretically its time to see something practically in action. Let's make small project to understand how we can implement the same. In Globalization folder you can run the "LoginScreen.aspx" to see it practically. Below goes the explanation.

We will make a simple login screen which we will try to use for English as well as Greek.

Note: - I was thinking of using Hindi as the second language. But while writing this tutorial my Hindi culture settings was not properly installed so switched to Greek. Well I worked in Greece for 2 years it was a lovely country. This answer I dedicate to the wonderful days spent in Greece.

The login screen will display English settings when an English user logs in and Greek Settings when a Greek user logs in. So below are the steps to start with.

Name	Value
PageResource1.Title	Login Page
lblUserIdResource1.Text	User ID
lblPasswordResource1.Text	Password

```
<asp:Label ID="lblUserId" runat="server" meta:resourcekey="lblUserIdResource1" Text="User ID" Width="80px"></asp:Label>

<% Page Language="C#"
AutoEventWireup="true"
CodeFile="LoginScreen.aspx.cs"
Inherits="_Default"
Culture="auto"
meta:resourcekey="PageResource1"
UICulture="auto" %>
```

Meta:resourcekey needs to be defined in the page directive

Figure 14.11 : - Culture Auto in action

In the above figure you can see the login page. You can find the same in CD as named “LoginScreen.aspx”. It’s a simple page with two labels and two text boxes. Now the labels values i.e. “User ID” and “Password” should be changed according to regional settings set on the browser. So below are the steps for the same:-

- √ Make two resource files as shown below one for Greece and other for English. There are three values defined for “Userid”, “Password” and the main title of the page. One important thing to note is the naming convention of the files. You need to tag the naming convention with the language code. You can see from the below figure the resource files naming convention is divided in two three parts File name, Language code and resource file extension. In this sample we will demonstrate for English and Greek language so I tagged the file with “el” language code.

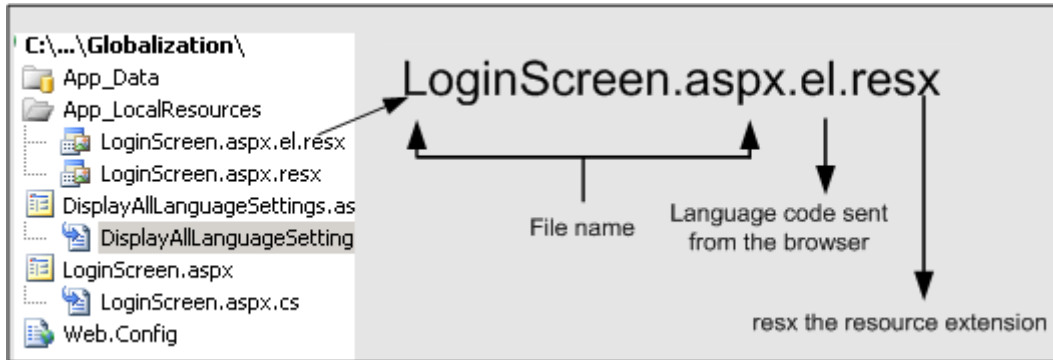

Figure 14.12 : - Resource file naming conventions

Below are the two resource files defined.

Name	Value	Name	Value
lblPasswordResource1.Text	Κωδικός πρόσβασης	PageResource1.Title	Login Page
lblUserIdResource1.Text	Όνομα χρήστη	lblUserIdResource1.Text	User ID
PageResource1.Title	Login Page(GR)	lblPasswordResource1.Text	Password

↑
Greek Resource file
↑
English Resource file

Figure 14.13: - Greek and English resource files

-
- √ Once you have defined your resource files we need to define two attributes “UICulture=Auto” and “Culture=Auto”. See the above figure “Culture Auto in Action”.
 - √ Final step you also need to define resource key at the UI object level. You can see a sample of the same in figure “Culture Auto in Action”.

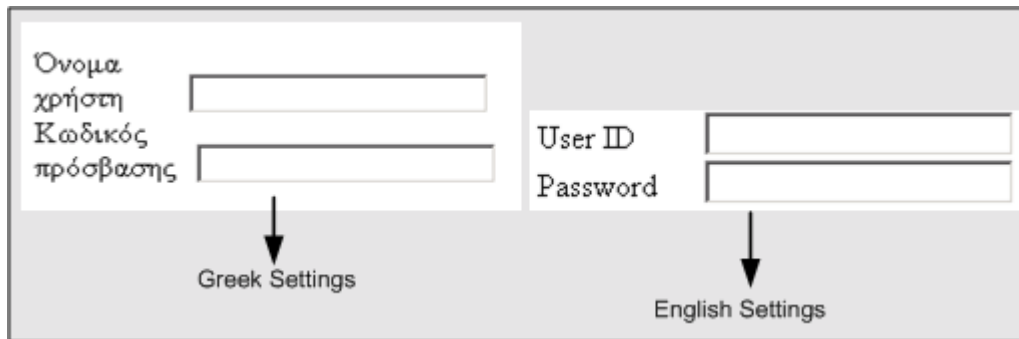

Figure 14.14 : - Login screen according to settings

Compile the project, run and see the output after changing regional settings for both languages. You should see different outputs as shown in the above figure. With out a single line of code everything works.... That’s the magic of “UICulture=Auto” attribute.

Note: - You can the get the above source code in “Globalization” folder. See for “LoginScreen.aspx” page.

Note: - In the further section we will answer all the below questions in one shot.

(B)What are satellite assemblies?

(A)How do we generate Satellite assemblies?

(A)What is AL.EXE and RESGEN.EXE?

In the previous question you have seen how we can use resource files to store data according to the localized languages. But when you actually go for deployment you will not like to also install the “resx” or “txt” files. It’s definitely not a good deployment practice to install data which can be easily modified. In short some how we should install this in a binary

format so that no end user can change it. That's why Microsoft introduced satellite assemblies.

Satellite assemblies are assemblies which do not contain source code. They only contain resource files. You can create a satellite assembly using `rsgen.exe` and `al.exe`. They are in binary DLL format which makes it easier to ship it during deployment. So finally during deployment you do not need to ship the `resx` files but only the compiled satellite DLL.

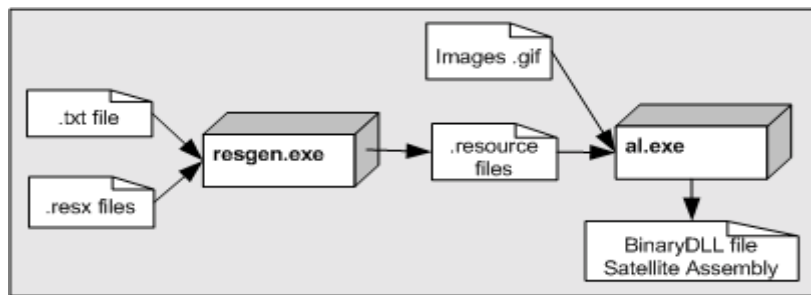

Figure 14.15 : - `resgen.exe` and `al.exe` in action

The above diagram will give you a complete picture of how to generate Satellite assembly. You can see from the above figure we need two exe `resgen.exe` and `al.exe`. Once you made your `resx` file or text file you should first convert in to a “.resource” files. This is done by using the `resgen.exe`. Below is the command snippet for `resgen.exe` where `LoginScreen.aspx.el.resx` is the `resx` file and output is `Greek.resources` file. If you do not provide the output file name it will generate “`LoginScreen.resources`”.

`resgen LoginScreen.aspx.el.resx Greek.resources`

You can also generate `resx` files from `txt` file using `resgen.exe` below is the code snippet for the same:-

`resgen MyLanguage.txt MyLanguage.resx`

The above command snippet will generate a `MyLanguage.resx` using `MyLanguag.txt` file. You can make a DLL using resource files and not `resx` so you should make this conversion.

Now once the resource file is generated its time make the compiled assembly of the same so that it can be shipped during deployment. This is accomplished by using the assembly linker tool `al.exe` provided by Microsoft. Below is the command code snippet for the same.

```
al.exe /out:el.dll /c:de /embed:greek.resources
```

In the /out switch you need to provide the output DLL name. /c you need to specify the culture of the resource file. /embed you need to specify all the resources which are present in the resource file. As said previously other than strings you can also put image files like GIF, BMP etc. So those physical resources you can specify in the /embed switch. You can specify more than one resource use “,” as a separator to specify more than one resource files.

(I)What’s the use of resource manager class?

ResourceManager class helps us to read the resource files and get the values using key.

First you need to create the object of resource manager. You need to specify the resource name and the assembly in the constructor.

```
private ResourceManager objResourceManager = new  
    ResourceManager("Globalization.resource",System.Reflection.Assembly.GetExecutingAssembly());
```

Once the resource manager is populated with details you can then use the GetString function to get by key. For instance in the below code snippet we are using the “cmdAddNew” key to get the value for button “cmdAddNew”.

```
cmdAddNew.Text = objResourceManager.GetString("cmdAddNew");
```

(A)What precautions do we need to take while deploying satellite assemblies?

When we deploy the assembly, the folder structure has to very organized. Below table shows how the folder structure should be organized. MainFolder is the main application folder. All satellite assemblies should be deployed in the Main application folder with in there own respective folder. The respective folder is denoted by the culture code.

Folder structure	Satellite DLL 's in folder	Culture
MainFolder	Language.dll	Invariant Culture
MainFolder/hi	Language.resources.dll	Hindi
MainFolder/el	Language.resources.dll	Greek
MainFolder/en-ca	Language.resources.dll	English Canada
MainFolder/ne	Language.resources.dll	Nepali

Figure 14.16 : - Satellite Assembly folder structure

You can see from the above figure Hindi satellite assembly is deployed in hi folder, Greek satellite assembly is deployed in el folder and so on. If the program does not find resource file for a culture it uses the invariant culture satellite assembly. The above folder structure is a strict requirement when we deploy the satellite assembly. Any mismatch in the folder structure will lead to inappropriate results.

(A)Can we get a strongly typed resource class rather than using resource manager?

In the previous question we had seen how resource manager class can be used to read the string from the resource file. But there has been considerable improvement in VS.Net 2005 for resource support. You no more need to load using resource manager class. Though Microsoft has still kept it for backward compatibility. You can now get strongly typed classes in your VS.NET intellisense as shown in the figure below.

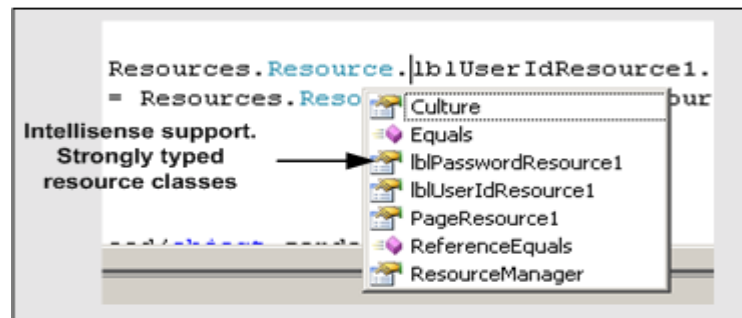

Figure 14.17 : - Strongly typed resource class

All belong to Resources namespace. Let's do a small sample and see how the strongly typed classes work in VS.NET 2005 and the simplicity which they bring while implementing globalization in projects. Below is the screen shot of the project. It's basically a simple login screen with user id and password text boxes. User has options to select the language. Currently only two languages are provided English and Greek. Depending on the languages selected the user id and password label values will be displayed.

A screenshot of a login form. The form contains three main elements: a text input field for the username, a text input field for the password, and a dropdown menu for language selection. The labels for the input fields are in Greek: "Όνομα χρήστη" (Username) and "Κωδικός Πρόσβασης" (Access Code). The dropdown menu is currently set to "Greek" and is open, showing a list of options: "Greek", "English", and "Greek". The second "Greek" option is highlighted in blue.

Figure 14.18 : - Strongly typed project

Note: - In the globalization project you can get the project sample in "LoginScreenUsingStrongType.aspx".

Below is the code snippet which describes the various important sections of the code. First thing are the resource files. We have generated two resource files one for Greece with el and second is the general resource file which will be used when the regional code does not match.

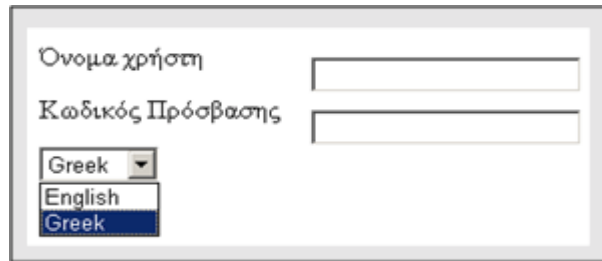
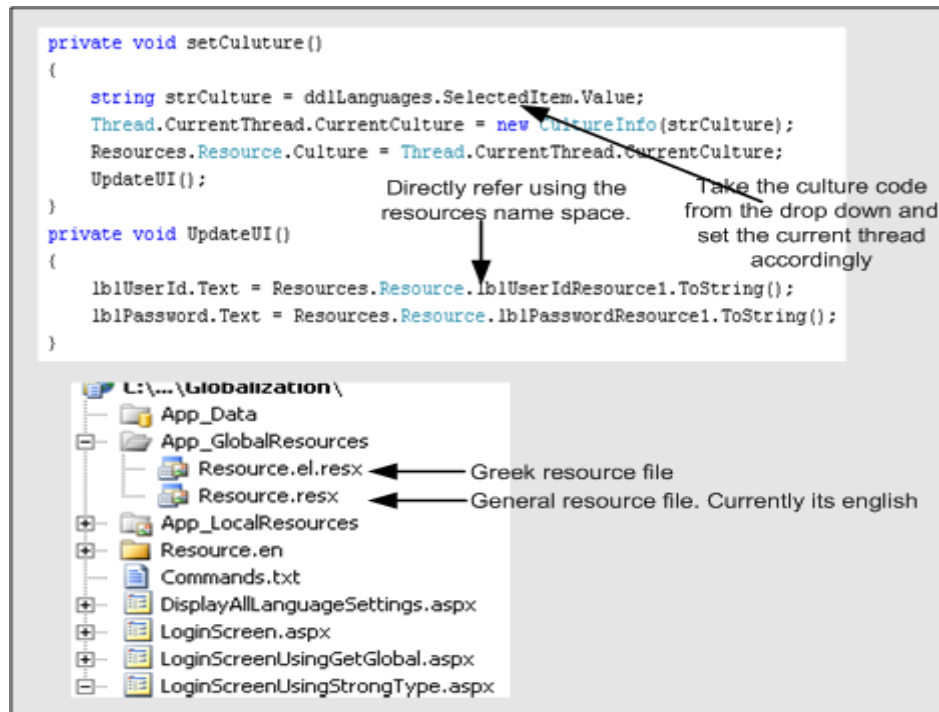

Figure 14.19 : - Walkthrough for using the resources namespace

There are three important steps in the code:-

- √ First is set the culture information for the current thread with the new culture info object. StrCulture has the language code which is currently selected in the drop down.

Thread.CurrentThread.CurrentCulture = new CultureInfo(strCulture);

- √ We set the same culture to the Resource class.

Resources.Resource.Culture = Thread.CurrentThread.CurrentCulture;

- √ Now we are all set to use the value.

lblUserId.Text = Resources.Resource.lblUserIdResource1.ToString();

```
lblPassword.Text = Resources.Resource.lblPasswordResource1.ToString();
```

Note: - You can get the same from globalization folder in "LoginScreenUsingStrongType.aspx". Try to add a new language and most of the fundamentals will be clear.

(A)Can you explain the fundamentals of “GetGlobalResourceObject” and “GetLocalResourceObject” functions?

These two functions belong to the HttpContext object. Using it you can get the object reference of the resource object. For instance you can see from the below code snippet we have got reference to the Global resource object and we are trying to get the value for “lblUserIdresource1” key.

```
lblUserId.Text=HttpContext.GetGlobalResourceObject("Resource",  
"lblUserIdResource1 ").ToString();
```

Note :- In the same globalization folder there is "LoginScreenUsingGetGlobal.aspx" which demonstrates how "GetGlobalResource" works.

One short note because “GetGlobalResourceObject” and “GetLocalResourceObject” operate from within current HttpContext. It uses what the regional settings are sent from the browser end.

(A)Can we sign a satellite assembly?

Yes you can sign the satellite assembly using the /keyfile switch which takes “.snk” file as the input parameter.

```
al /res:MyLanguage.resources /c:de /keyfile:MyLang.snk out:MyLanguages.resources.dll
```

(I)Can you explain collation sequence in sql server?

First let's define collation.

Collation sequences are set of rules which determine how the data is sorted and compared. Sorting rules can be defined with options with case-sensitivity, accent marks, kana character types and character width.

Case sensitivity

If A and a, B and b, etc. are treated in the same way then it is case-insensitive. A computer treats A and a differently because it uses ASCII code to differentiate the input. The ASCII value of A is 65, while a is 97. The ASCII value of B is 66 and b is 98.

Accent sensitivity

If a and á, o and ó are treated in the same way, then it is accent-insensitive. A computer treats a and á differently because it uses ASCII code for differentiating the input. The ASCII value of a is 97 and á is 225. The ASCII value of o is 111 and ó is 243.

Kana Sensitivity

When Japanese kana characters Hiragana and Katakana are treated differently, it is called Kana sensitive.

Width sensitivity

When a single-byte character (half-width) and the same character when represented as a double-byte character (full-width) are treated differently then it is width sensitive.

(A)How do we define collation sequence for database and tables?

You can create a database with language specific collation sequence. For instance in the below create statement tblCustomer is created by Latin language collation sequence.

```
Create database tblCustomer collate Latin1_General_BIN
```

You can also create tables with particular collation sequence. Below is the create table syntax for the same.

```
Create table tblCustomer
```

```
(
```

```
[CustomerCode] char(10) COLLATE Albanian_CI_AI_KS_WS NULL,
```

```
[EntryDate] [char] (8) COLLATE Korean_Wansung_Unicode_CS_AS_KS NOT  
NULL ,
```

```
[CustAbbrev] [char] (2) COLLATE SQL_Latin1_General_CP1_CI_AS NOT  
NULL
```

```
)
```

(A)Can we change the order in a select query with a specified collation sequence?

Yes we can specify a collate sequence in the order by clause. That will change the sort according to the collation defined in the order by claused.

```
ORDER BY  
{  
  order_by_expression  
  [ COLLATE collation_name ]  
  [ ASC | DESC ]  
} [ ...n ] ]
```

(A)Can you list best practices for globalization and localization?

Below are the best practices while developing international language support software:-

- √ Do not hardcode strings or user interface resources.
- √ Make sure your application depends on Unicode.
- √ When ever you read or write data from various encoding make sure you use the System.text namespace. Many programmers assume ASCII data.
- √ While testing test it with actual international data and environments.
- √ Whenever we manipulate data for instance numbers, dates or currency make sure that you are using culture-aware classes defined in System.Globalzation namespace. Below is the table which specifies in more detail about the functionality and the classes to be used to achieve the same.

Functionality	Classes to be used
Sorting	While sorting use the SortKey class.
Comparing	Any string comparisons should use the CompareInfo class.
Date and time formatting	For date and time formatting use the DateTimeFormatInfo class.
Number formatting	For number formatting use the NumberFormatInfo class. This will ease you from the comma and dot separator issue.

Figure 14.20 : - Functionality and classes used

- √ If a security decision is based on the result of a string comparison or case change operation, perform a culture-insensitive operation by explicitly specifying the `CultureInfo.InvariantCulture` property. This practice ensures that the result is not affected by the value of `CultureInfo.CurrentCulture`.
- √ Move all your localizable resources to separate DLL's.
- √ Avoid using images and icons that contain text in your application. They are expensive to localize.
- √ Allow plenty of room for the length of strings to expand in the user interface. In some languages, phrases can require 50-75 percent more space.
- √ Use the `System.Resources.ResourceManager` class to retrieve resources based on culture.
- √ Explicitly set the `CurrentUICulture` and `CultureInfo.CurrentCulture` properties in your application. Do not rely on defaults.
- √ Be aware that you can specify the following three types of encodings in ASP.NET:
 - √ `requestEncoding` specifies the encoding received from the client's browser.
 - √ `responseEncoding` specifies the encoding to send to the client browser. In most situations, this should be the same as `requestEncoding`.
 - √ `FileEncoding` specifies the default encoding for `.aspx`, `.asmx`, and `.asax` file parsing.

(A)Why is the culture set to the current thread?

First let me explain this question. If you look at the code snippet of how to set the culture info.

Thread.CurrentThread.CurrentCulture = new CultureInfo(strCulture);

It uses the current thread to set it. What does that mean? Let's drill down a bit of how IIS handles request to understand this concept. When any user requests a resource from IIS like an ASPX page or any other resource. IIS services that request in his own thread. That means if 100 users have requested some resource from IIS he will serve every request in its own thread. In short IIS will spawn 100 threads to service the 100 request. It's very much practically possible that you can have different locale in different threads. So when we set a culture we can not set it for the whole application as it will affect all the requests. So when we set a culture we set it to a particular thread rather to the whole application.

Note: - Phew!!! Big chapter right. Yes even I feel the same thing. But I am sure that we have covered most of the points. But yes who knows what's up in the mind of the interviewer.... We can be just prepared for the worst.

15. Windows Communication Foundation(Vista Series)

Note: - PHEW... One more mountain to capture, one more road to walk, one more area to prepare, one more new technology to learn.....I think that's what we call, a life of software professional. Hmmm..... Talks and Jokes apart, welcome to one more new technology introduced by Microsoft WCF (Windows Communication Framework).

(B) What is .NET 3.0

In one simple equation .NET 3.0 = .NET 2.0 + Windows Communication Foundation + Windows Presentation Foundation + Windows Workflow Foundation + Windows CardSpace.

Note :- All the above section (WCF , WPF and WWF) have dedicated chapters. We are not covering Windows Cardspace.So we will go through a quick definition for it and then go deeper in to WCF.

(B) What is Windows CardSpace ?

It was previously known by its codename InfoCard. It is a framework by microsoft which securely stores digital identities of a user and provides a unified interface to choose the identity for a particular transaction, such as logging in to a website. Windows Card Space is a central part of microsoft's effort to create an identity metasystem , or a unified , secure and interoperable identity layer for the internet.

(B) What is WCF?

First let's give a short answer to this: - "WCF (Indigo was the code name for WCF) is a unification of .NET framework communication technologies ". Ok let me tell you a story.

Note: - I am bad at story telling but if you are reading this at night it can serve you as good technical bed time story.

Long Long time ago there lived a hard working and a nice architecture. He used to work for a travel agent with his small and happy team software professionals. Travel agent had tie ups with many big flight carriers. The nice and hardworking architecture and his team developed a nice booking engine by which you can book tickets through any of the flight

carriers. The Travel Agent Company was very happy with the architecture and his team member's achievements.

As time passed by the travel agent's business grew in multiples. Travel agent started his own franchise. Travel agent wanted to provide this booking engine service to his franchise. So one fine morning he called the hard working architecture. Architecture was very excited of the new work and started on it day and night. He prepared a list of franchise and made personal visits to see what infrastructure they had. He saw all the franchise worked in Microsoft Windows platform. Booking engine was located in the main head office and all the franchise should communicate to this booking engine. After discussing with his team members he concluded that the best way to communicate is .NET remoting because the head office where the booking engine was hosted was also on windows platform and the other franchise where also on the same. He then worked day and night with his team members to implement .NET remoting to enable communication between the franchise and the booking engine hosted in the head office. After months he rolled out his project successfully.

Travel Agent was very happy with his architecture and the team. Travel agent was now providing his booking service to his franchise in the most efficient manner. Time passed by and because of the good automated booking service more companies wanted to take the franchise from the travel agent. But the big issue was many of the franchise did not have windows operating system. They worked on Linux and other Non-Microsoft operating systems. Due to this limitation travel agent was losing lot of franchise business. So one fine day they again called the Architecture and said that the booking engine should also be available to Non-Microsoft platforms. Architecture again went in to action. He setup a high level team meeting and discussed the best solution on Non-Microsoft platforms. After long discussion's they concluded Web services as the solution. His team again went in to action and implemented the solution. So now his booking engine architecture was working with two technologies .NET remoting and Web services. He kept .NET remoting so that he can get speed and performance benefits from common windows platform and he also kept Web services so that he can operate seamlessly with Non-Microsoft platforms.

Travel agent was now at his peak of happiness as he had the world at his tips. Franchise now started making huge ticket bookings through the booking engine. Booking engine had the capacity of serving 20 tickets / second but it had now to serve 50 tickets / second. End franchise client had to wait to get response and was not able to process the next ticket booking until the first one was served. Travel Agent started receiving huge

complaints because of this synchronous processing. They again called the architecture and proposed the problem before him. Now architecture was really at a fix as he did not want to touch the booking engine logic to increase performance. So he concluded to use MSMQ (Microsoft Message Queuing) service. He analyzed that the main problem was that the travel agent had to wait until his first ticket booking is not completed. So when the travel agent makes a booking it will come and fall in the queue and release the travel agent. Booking engine will always poll for this queue. When the booking engine finishes he will publish the booking results back to the queue. Travel agent client can then come at his leisure and see the results. Again he and his team mates implemented this solution.

Every one in the travel company was really happy and impressed by the architect and his team members. As time passed by the booking engine was serving huge ticket bookings. Travel Agent then felt a huge necessity of a good security model with the booking engine. Again the architecture was called; he again had a kick of meeting and proposed WSE as the security solution. Implemented the same and everything was fine.

After some days travel agent wanted to start a scheme to book group family ticket bookings through the booking engine. Till now the travel agent was booking one ticket at a time. But soon he started getting lot of orders to book group family tickets. He wanted to incorporate the same in the booking engine with consistency. Consistency means if any of the ticket booking fails in the family booking all the tickets should be cancelled. In short either all the tickets in the family are booked or none of them. Looking at the need Architecture thought to use COM+ Services to manage transactions.

Below is the top level design document of the project. Architecture and his team were now feeling the pressure and heat of managing multiple technologies to achieve. The happy architecture now started becoming frustrated. His team members started slogging for night as they had to work on multiple technologies at one time.

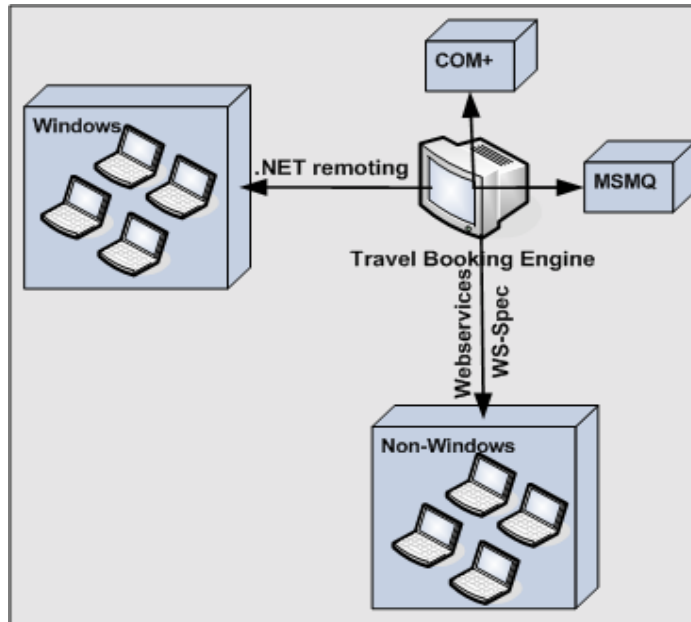

Figure: 15.1 - Travel Design Architecture

The frustrated architect finally went to www.microsoft.com to find one solution. He was then introduced to WCF. And after implementing WCF the architect lived happily for ever. Hope so.... ?

Hmmmm did you like the story ok it was fiction. Jokes apart.

In short WCF is a unification technology which unites the following technologies:-

- √ .NET remoting
- √ MSMQ
- √ Web services
- √ COM+.

Below figure depicts WCF fundamentals pictorially.

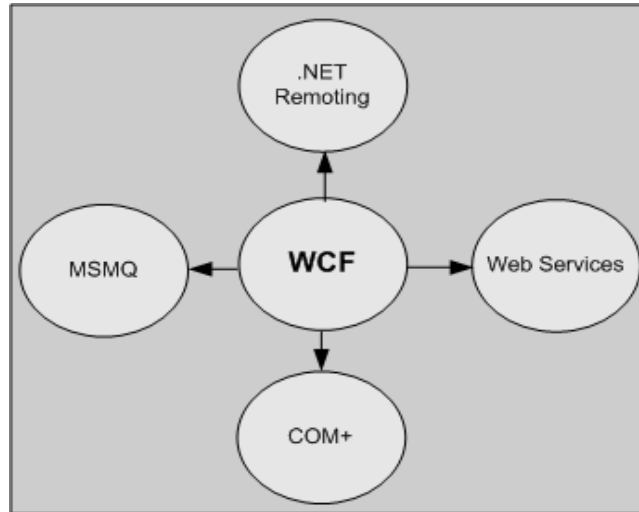

Figure: 15.2 - WCF Components

(I) what are the important principles of SOA (Service oriented Architecture)?

WCF is based on SOA. All big companies are playing big bets on SOA. So how can Microsoft remain behind? So in order to implement SOA architecture easily you need to use WCF.

SOA is based on four important concepts:-

√ Boundaries are well defined

In SOA everything is formalized. The client who is consuming the service does not need to know how the implementation of the service is done. If you look at some old methodologies of communication like DCOM. Any changes at server level the client also has to change. So the server and client implementation was so much bound that changes need to be done at all places. In SOA the rule is if you do enhancement you do not need to change anything at the client. SOA based application only understands that there is an end point, contract and bindings.

Note: - Just to clarify shortly about end point and contract. Any SOA service is exposed through an end point. End point defines three important aspects What, Where and How. We will understand more details of the same in the later questions.

√ Services evolve

Change is the law of nature and services will also evolve. In SOA services can be versioned and you can host those services in new end points. For instance you have a service called as "SearchTickets (TicketNumber)" which gives details based on TicketNumber and its exposed on end point "ep1". Tomorrow you want make your SearchTickets service more useful by also providing an extra option of allowing him to search by passenger name. So you just declare a new end point "ep2" with service "SearchTickets (TicketNumber, Passenger Name)". So the client who is consuming the service at end point ep1 continues and at the other end we have also evolved our service by adding new end points ep2.

√ Services share only schemas and contracts

Services use Schemas to represent data and contracts to understand behavior. They do not use language dependent types or classes in order to understand data and behavior. XML is used to define schemas and contracts. Due to this there is not heavy coupling between environments.

√ Service compatibility is policy based

Policy describes the capabilities of the system. Depending on policies the service can degrade to match the service for the client. For instance your service needs to be hosted for two types of client one which uses Remoting as the communication methodology while other client uses DCOM. An ideal SOA service can cater to both of them according to there communication policies.

Note: - Many people assume Web services are the base for SOA. The answer is 50 % right. What web services lack is the policy based Service compatibility. If you host a web service it can only serve with HTTP communication channel and SOAP message. Any other type of client trying to communicate he will not degrade it self. This is what is provided by WCF. You can host the service in one or more mode. For instance you can host a WCF service using remoting and ASMX.

(I) what are end points, contract, address and bindings?

The above terminologies are the core on which SOA stands. Every service must expose one or more end points by which the service can be available to the client. End point consists of three important things where, what and how:-

√ Contract (What)

Contract is an agreement between two or more parties. It defines the protocol how client should communicate with your service. Technically it describes parameters and return values for a method.

√ Address (Where)

An Address indicates where we can find this service. Address is a URL which points to the location of the service.

√ Binding (How)

Bindings determine how this end point can be accessed. It determines how communications is done. For instance you expose your service which can be accessed using SOAP over HTTP or BINARY over TCP. So for each of these communications medium two bindings will be created.

Below figure show the three main components of end point. You can see the stock ticker is the service class which has an end point hosted on www.soa.com with HTTP and TCP binding support and using Stock Ticker interface type.

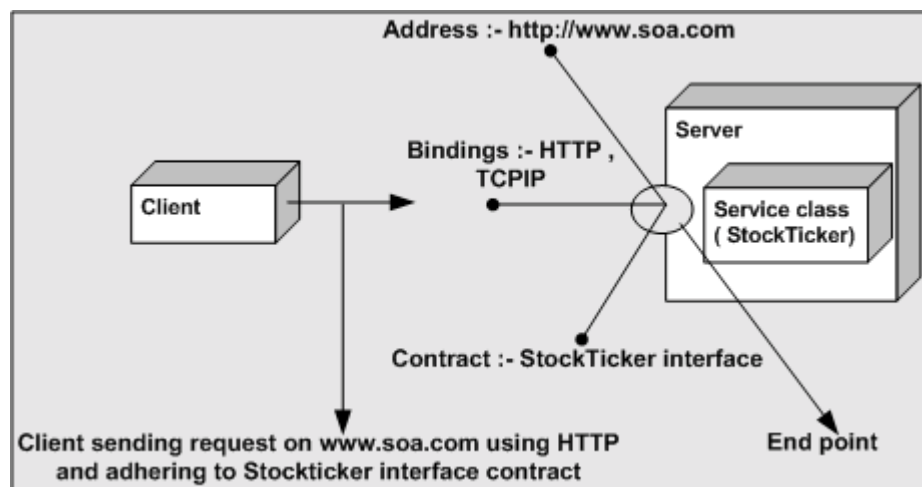

Figure 15.3 : - Endpoint Architecture

Note: - You can also remember the end point by ABC where A stands for Address, B for bindings and C for Contract.

(A) Which specifications does WCF follow?

WCF supports specifications defined by WS-* specifications. WS-* specifications are defined together by Microsoft, IBM, SUN and many other big companies so that they can expose their service through a common protocol. WCF supports all specifications defined we will understand them one by one.

Messaging (WS-Addressing):- SOAP is the fundamental protocol for web services. WS-Addressing defines some extra additions to SOAP headers which makes SOAP free from underlying transport protocol. One of the good things about Message transmission is MTOM, also termed as Message Transmission Optimization Mechanism. They optimize transmission format for SOAP messages in XML-Binary format using XML optimized packaging (XOP). Because the data will be sent in binary and optimized format it will give us huge performance gain.

Security (WS-Security, WS-Trust and WS-SecureConversation):- All the three WS- define authentication, security, data integrity and privacy features for a service.

Reliability (WS-ReliableMessaging):- This specification ensures end-to-end communication when we want SOAP messages to be traversed to and fro many times.

Transactions (WS-Coordination and WS-AtomicTransaction):- These two specifications enable transaction with SOAP messages.

Metadata (WS-Policy and WS-MetadataExchange):- WSDL is an implementation of WS-MetadataExchange protocol. WS-Policy defines more dynamic features of a service which can not be expressed by WSDL.

We have stressed on the WS-* specification as it's a specification which a service has to follow to be compatible with other languages. Because WCF follows WS-* specifications other languages like JAVA, C++ can also exploit features like Messaging, Security, Reliability and transactions written in C# or VB.NET. This is the biggest achievement of WCF to integrate the above features with other languages.

Note: - During interview the interviewer expects that you know what WS- specifications are supported by WCF and its advantages with respect to interacting with other languages.*

(A) What are the main components of WCF?

We need to define three main components in WCF:-

- √ Service class.
- √ Hosting environment
- √ End point

(I) Can you explain how End points, Contract, Address and Bindings are done in WCF?

(I) what is a service class?

(I) what is a service contract, operation contract and Data Contract?

Note: - This section will answer all the questions above. The best way to understand the above concepts is to do a sample.

In this example we will make simple service which displays the total cost of the complete product group. In simple words this service will take three parameters per product cost, number of products and the product name. In return the service will return the total cost of all the products by multiplying number of products * cost per product. As we go ahead in this explanation we will try to understand all the terminologies which are asked in the above question.

First you need to create a Winfx service project. You can see in the below figure we have selected the Winfx project.



Figure 15.4: - Create new WinFX Service class

In this project we add a new class and name it as “serviceGetCost.cs”. This class will have our core implementation and this is the class which has all the action. The service class which has to be exposed to the external client. We need to use the ServiceContract attribute to mark it as a service class.

Service Contract attribute define saying which application interface will be exposed as a service.

You can see in the below code snippet we have made an interface and marked it as Service Contract. It's not essential that you need to use an interface you can also use a simple class and mark it as Service but interface represent a contract and do not have

implementation. In short they stand at a very higher level of abstraction. So as a good design practice using interface to represent a service contract makes more sense.

The next thing to note is the `OperationContract` attribute.

`OperationContract` dictates which methods should be exposed to the external client using this service.

It defines individual exchange or request and replies. In the current sample we have defined `GetTotalCost` method which will be used by the end client to get the total cost results.

The next thing to note in the code snippet is the `DataContract` attribute. In the previous two steps we have exposed class as a service by using `ServiceContract` and methods by using `OperationContract`. Every operation will definitely do some kind of data transfer.

`Data Contract` attributes defines which type of complex data will be exchanged between the client and the service. They determine which parameters to be serialized.

When you are using simple data types like `int`, `bool` etc it's not necessary that you need to mark the data contract attribute. Because you will always find matching types on the client. But complex structure like one shown in the below code snippet you will need to define a data contract. Remember data contract define how this data will be passed during transmission. In short data contract attribute define how data will be serialized will transmission.

Note: - Some interviewers really get impressed if you say Data Contract define how the data will be serialized during transmission. This sentence will really show the depth of understanding the Data Contract concept.

In the below sample we have marked the structure `productdata` to be serialized.

```
[ServiceContract()] ← Service Contract defines message patterns
public interface IServiceGetCost
{
    [OperationContract] ← This attribute defines that this method will be exposed as a
    string GetTotalCost(productData objProductData);
}
[DataContract] ← This attribute defines the data types which will be exchanged between
public struct productData
{
    [DataMember] public int Qty;
    [DataMember] public string strProductName;
    [DataMember] public double costPerProduct;
}
public class serviceGetCost : IServiceGetCost ← Service Contract define message
{
    public string GetTotalCost(productData objProductData)
    {
        double totalCost = objProductData.Qty * objProductData.costPerProduct;
        return " The Product Name is " + objProductData.strProductName +
            "and total cost is " + totalCost.ToString();
    }
}
```

Figure 15.5:- The Service class

As data contract are all about serialization you need to import System.Runtime.Serialization name space.

In the next step we implement the GetTotalCost function. It just returns a simple string with product name and the total cost of all products.

Once our service class is done its time to host this service. There are various ways of hosting a WCF service we will look in to the same in the next question. For the current example we will host in their own process.

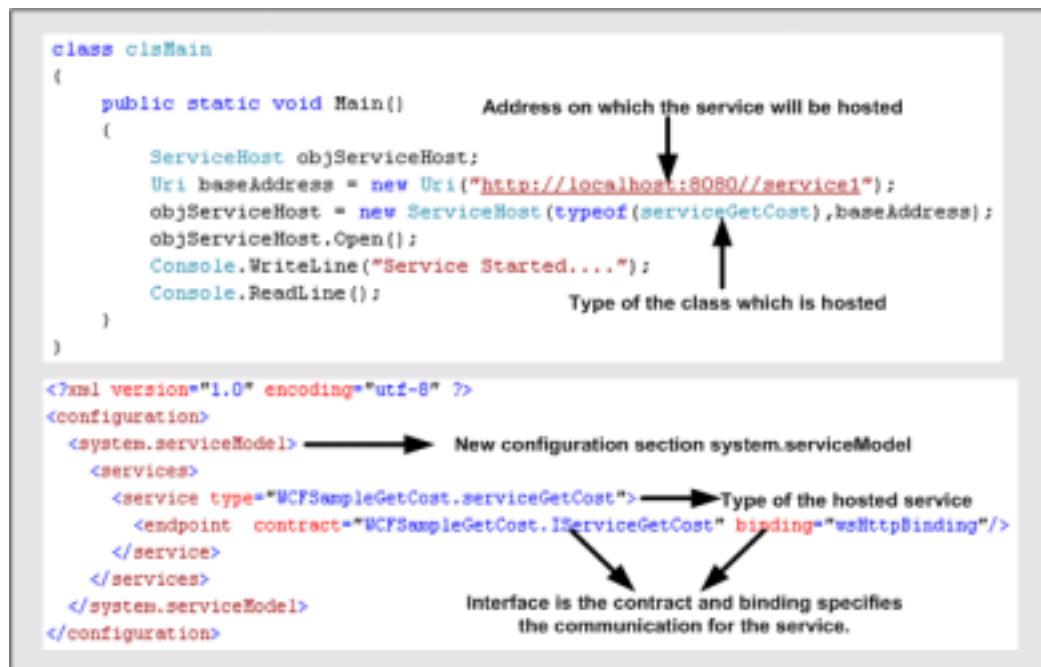

Figure 15.6 : - Hosting the service

Hosting the WCF service needs two things one is the config file and second is the hosting code on startup. Because we are hosting this service in its own application process this needs to be a windows application. So first let's have a look what entries do we need to make in the App.config file. In the above figure everything is clear but let's understand all the section defined in the App.config file.

In the configuration section we need to add a new section `<system.serviceModel>`. The most important part of `<system.serviceModel>` is the endpoint tag. As said in the previous answer End point gives three important answers Where, What and How. In short where is the service, what the contract of the service is and how do we communicate with the service.

In the above code snippet we have only defined the contract i.e. what and how that is bindings. The where is defined in the application entry point static void main ().

So the contract attribute defines the interface and binding says that the end clients can communicate using “HTTP” protocol.

In Static void Main method we create an object of ServiceHost class and use the open method to host the service. We have used the URI object to define the address where the service will be hosted.

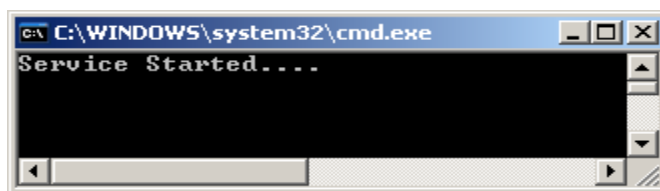

Figure 15.7 : - Service Started

If you compile the project you will see something as shown in the above figure. This says that the service is up and running and ready to serve any WCF client. Now its time to develop consumer which will consume this WCF service. Microsoft has provided a decent automation to generate the client. So below figure depicts the various steps.

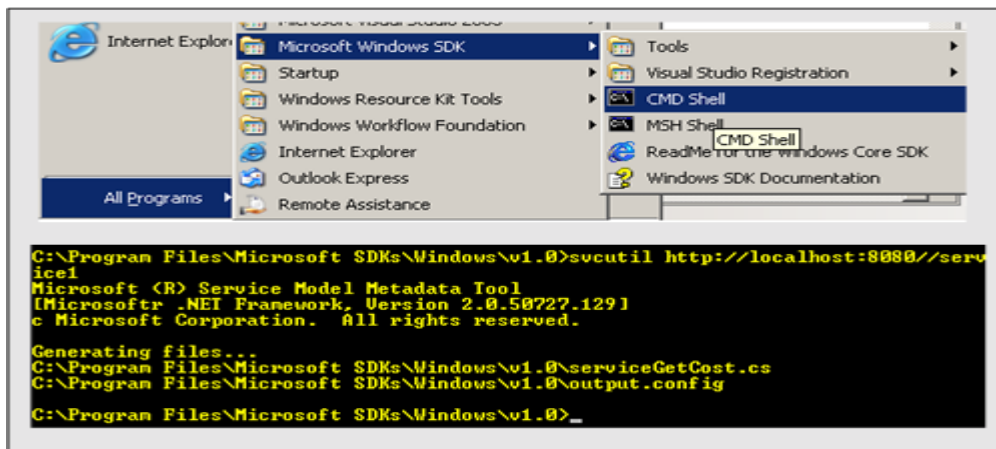

Figure 15.8 : - svcutil in action

Go to command prompt of windows SDK and run the following command:-

Svcutil <Service hosted URI>

In the above command <Service Hosted URI> is the URI on which the service is hosted. One you run the command against the URI it will generate two files one is the config file and the other is the proxy. You can see in the above figure two files are generated serviceGetCost.cs and output.config file. With the help of these two files we will make our client.

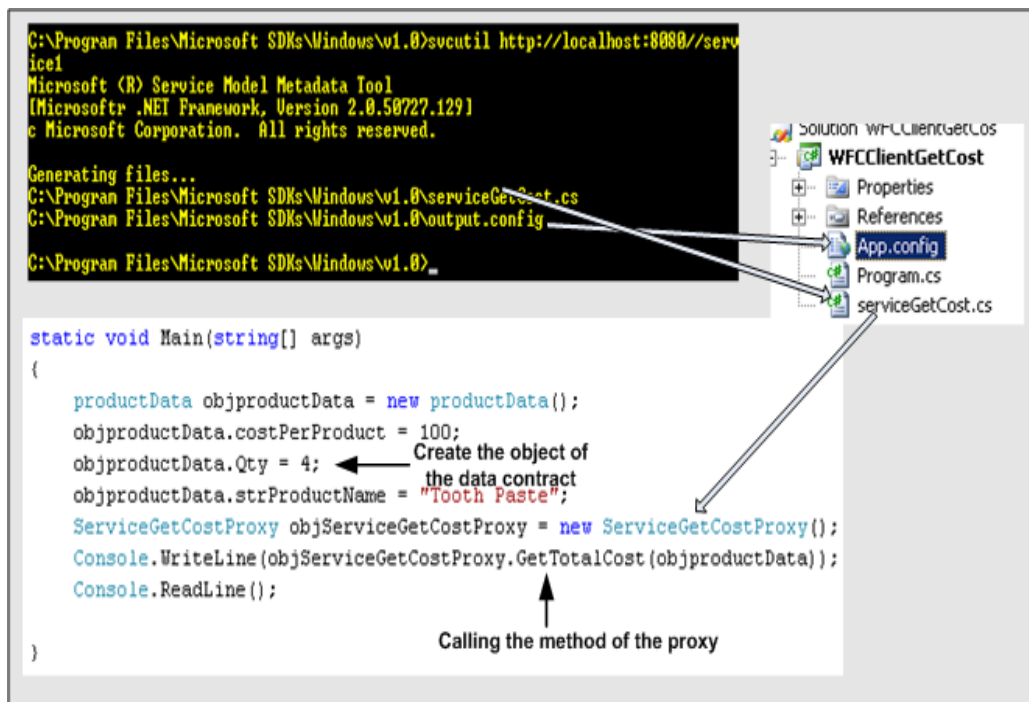

Figure 15.9 : - Client code walkthrough

You can see in the above figure we have made WFClientGetCost project. In that we have added output.config and serviceGetCost.cs to the client project. We have renamed output.config to app.config.

Once we have done with everything its time to write the client code which calls the proxy who in turn will call the service hosted. In the above figure you can see we have the client code also. It's a simple code we first created the object of the data structure set the values. Then we create the object of the service and call the GetTotalCost function.

If everything is compiled and you run the server and client, you should get your output as shown below.

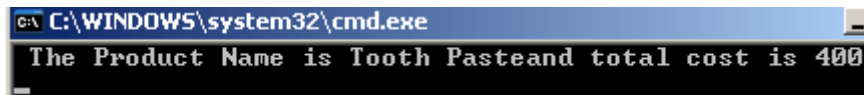

Figure 15.10 : - Output of WCF service

Note: - You can find source code for GetCost service in WCFGetCost folder in the CD.

(I) what are the various ways of hosting a WCF service?

There are three major ways to host a WCF service:-

- √ Self hosting the service in his own application domain. This we have already covered in the first section. The service comes in to existence when you create the object of ServiceHost class and the service closes when you call the Close of the ServiceHost class.
- √ Host in application domain or process provided by IIS Server.
- √ Host in Application domain and process provided by WAS (Windows Activation Service) Server.

Note: - This book does not cover the last hosting methodology provided. In the next question we will cover how to host a service in IIS process or application domain.

(I) How do we host a WCF service in IIS?

Note: - The best to know how to host a WCF in IIS is by doing a small sample. So what we will do is host the same GetCost sample which was self hosted in the previous question.

First thing you will need is to create the SVC file which exposes the service class. SVC file contains the pointer to the class. You can see from the figure below the class attribute points to the class whose interface is exposed by the service.svc.cs file. Also note the actual interface is in service.svc.cs file. Below figure has both the files service.svc which

has the class attribute which points to the service class and the interface which resides in service.svc.cs file. We have taken the same sample which was self hosted in the previous question.

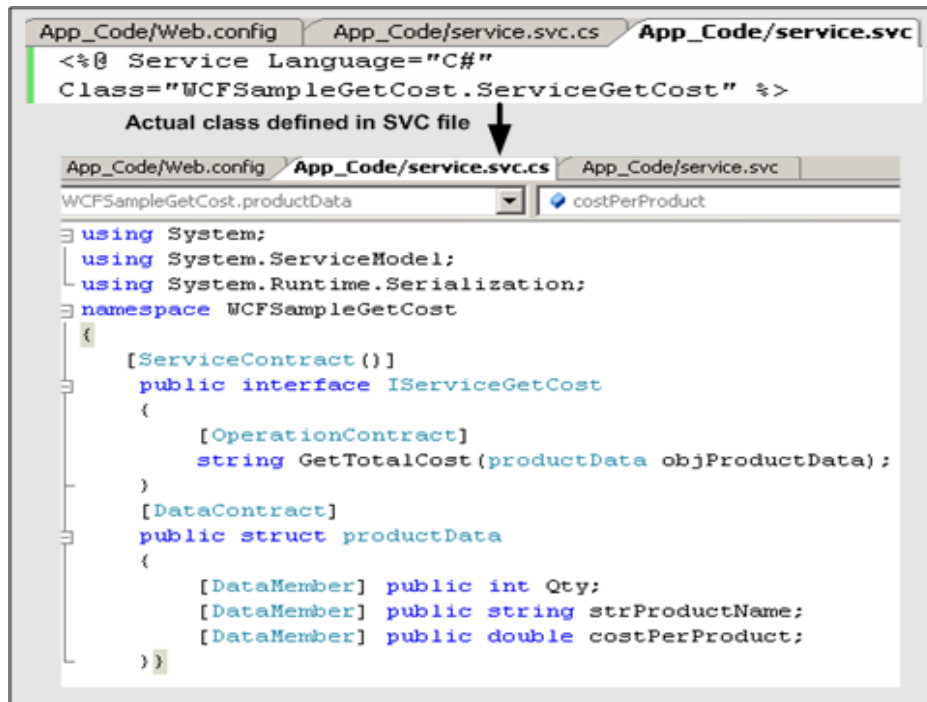

The screenshot shows a Visual Studio IDE with three tabs: 'App_Code/Web.config', 'App_Code/service.svc.cs', and 'App_Code/service.svc'. The 'App_Code/service.svc' tab is active and displays the following XML snippet:

```
<?@ Service Language="C#"
Class="WCFSampleGetCost.ServiceGetCost" ?>
```

Below this, a label 'Actual class defined in SVC file' has a black arrow pointing down to the 'App_Code/service.svc.cs' tab. This tab is active and shows the following C# code:

```
using System;
using System.ServiceModel;
using System.Runtime.Serialization;
namespace WCFSampleGetCost
{
    [ServiceContract()]
    public interface IServiceGetCost
    {
        [OperationContract]
        string GetTotalCost(productData objProductData);
    }
    [DataContract]
    public struct productData
    {
        [DataMember] public int Qty;
        [DataMember] public string strProductName;
        [DataMember] public double costPerProduct;
    }
}
```

Figure 15.11: - The SVC file and the behind code

We also need to provide implementation for the interface. So we have made a class ServiceGetCost which has the actual implementation. Below figure shows the same in detail. In the below figure you can also see the solution files.

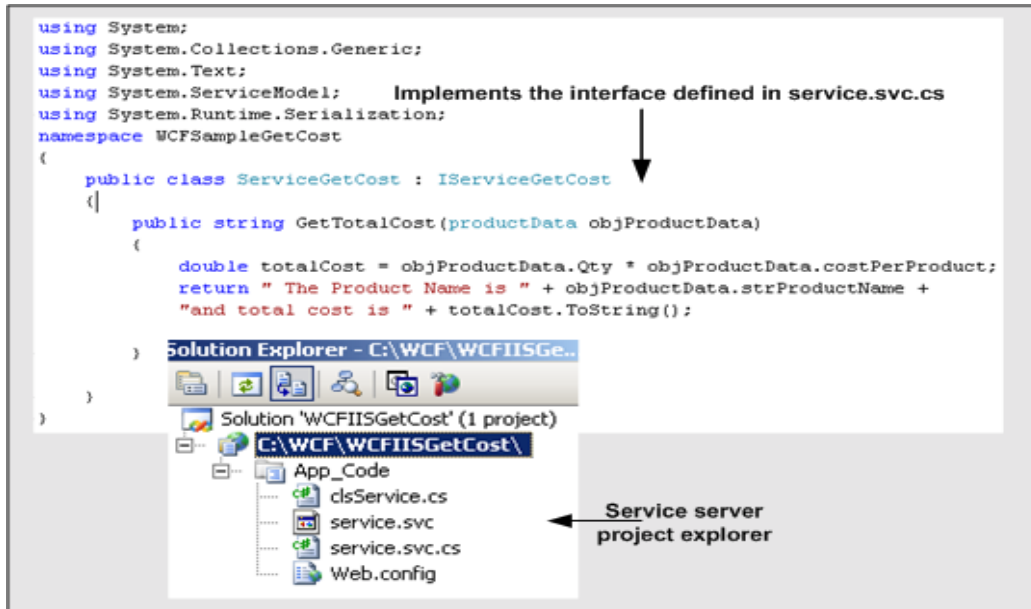

Figure 15.12: - Implementation of Service.svc.cs

We also need to specify the service type and endpoint in web.config file. Also note we have specified HTTP binding because we will be hosting the service on IIS.

```
App_Code/clsService.cs App_Code/Web.config App_Code/service.svc.cs App_Code/service.svc Start P...
<?xml version="1.0"?>
<configuration>
  <system.serviceModel>
    <services>
      <service type="WCFSampleGetCost.ServiceGetCost">
        <endpoint address="" contract="WCFSampleGetCost.IServiceGetCost"
          binding="wsHttpBinding"/>
      </service>
    </services>
  </system.serviceModel>
  <appSettings/>
  <connectionStrings/>
  <system.web>
    <compilation debug="false" />
    <!-- <authentication mode="Windows" /> -->
  </system.web>
</configuration>
```

Annotations in the image:

- An arrow points from the text "Interface of the service hosted on the end point" to the `contract="WCFSampleGetCost.IServiceGetCost"` attribute.
- An arrow points from the text "Need to specify HTTP protocol as it will be hosted on IIS" to the `binding="wsHttpBinding"/>` element.

Figure 15.13: - Web.config file for hosting service on IIS

Now that we are done with the coding part. We need to create the virtual directory in IIS. In the below figure in Step1 and Step2 we have shown how to create the virtual directory in IIS. One important thing to note while creating virtual directory set the access permission to execute.

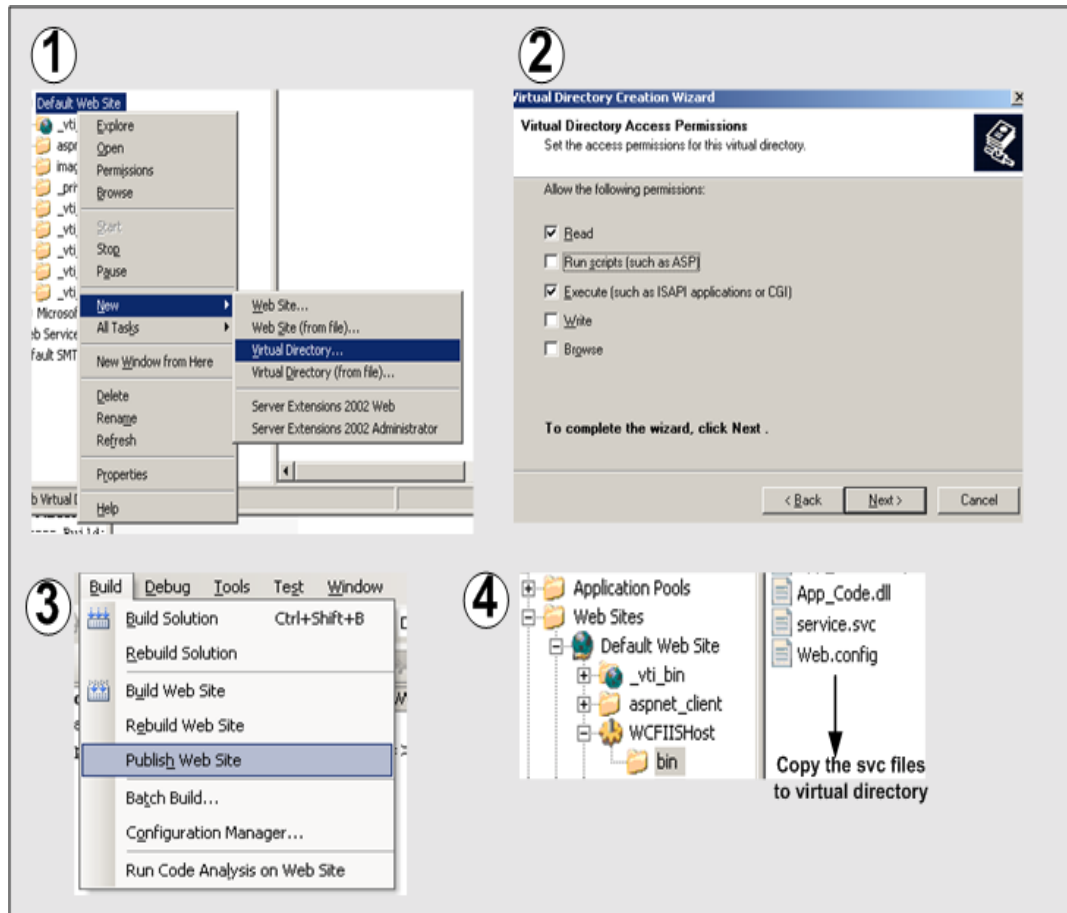

Figure 15.14 :- IIS Configuration

In the third step we will publish the website to our virtual directory. Note the fourth step in which we have copied the svc file so that the service can be requested.

Note: - ASP.NET compilation has changed in ASP.NET 2.0. In 2.0 there is no concept of solution files. So if you want to have full compiled DLL you need to publish the project to a virtual directory.

Once you have hosted the SVC file you can test the same by request the service.svc file. If everything works fine you will get something as shown in the below figure.

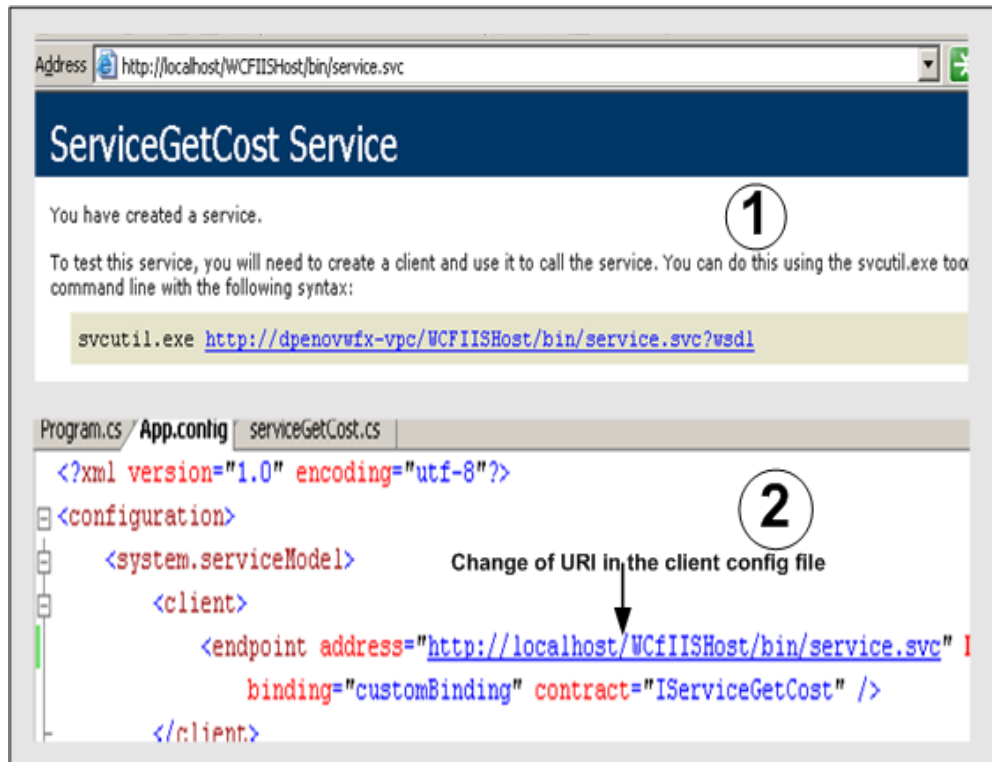
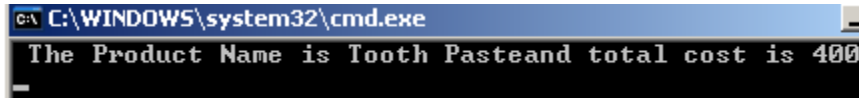

Figure 15.15:- IIS WCF client

Using the Svcutil.exe you will need to generate the proxy class and the config file. The proxy and config will be same as we had done for self hosting. The one important change is the address. The config file URL now points to the service.svc which is hosted on IIS. You can run the same client which we had created for self hosting. The only change you will need to do is change the endpoint address.



```
C:\WINDOWS\system32\cmd.exe
The Product Name is Tooth Pasteand total cost is 400
```

Figure 15.16:- Output of WCF client at IIS

LOL...You should get the same output which we had received for self hosting.

Note: - You can get the complete source code in CD in WCFIISGetCost folder.

(I) what are the advantages of hosting WCF Services in IIS as compared to self hosting?

There are two main advantages of using IIS over self hosting:-

Automatic activation

IIS provides automatic activation that means the service is not necessary to be running in advance. When any message is received by the service it then launches and fulfills the request. But in case of self hosting the service should always be running.

Process recycling

If IIS finds that a service is not healthy that means if it has memory leaks etc, IIS recycles the process. Ok let us try to understand what is recycling in IIS process. For every browser instance a worker process is spawned and the request is serviced. When the browser disconnects the worker process stops and you loose all information. IIS also restarts the worker process. By default the worker process is recycled at around 120 minutes. So why does IIS recycle. By restarting the worker process it ensures any bad code or memory leak do not cause issue to the whole system.

In case of self hosting both the above features you will need to code yourself. Lot of work right!!. That's why IIS is the best option for hosting services until you are really doing something custom.

Below figure shows where the recycle option is located in IIS. You need to click on the DefaultAppool and then Properties.

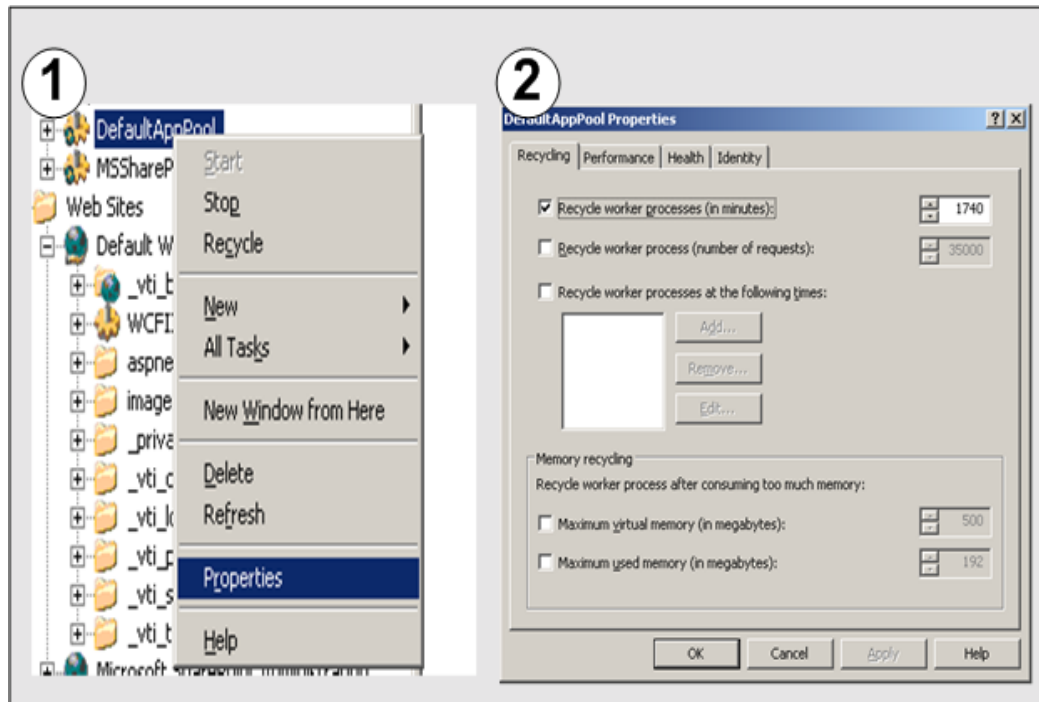

Figure 15.17:- IIS recycle option

(I) what are the major differences between services and Web services?

(I) what is the difference WCF and Web services?

Web services can only be invoked by HTTP. While Service or a WCF component can be invoked by any protocol and any transport type. Second web services are not flexible. But Services are flexible. If you make a new version of the service then you need to just expose a new end point. So services are agile and which is a very practical approach looking at the current business trends.

(A) What are different bindings supported by WCF?

WCF includes predefined bindings. They cover most of bindings widely needed in day to day application. But just incase you find that you need to define something custom WCF does not stop you. So let's try to understand what each binding provides.

BasicHttpBinding: - This binding is used when we need to use SOAP over HTTP. This binding can also be configured to be used as HTTPS. It can be also configured to send data in plain text or in optimized form like MTOM.

Note: - MTOM is discussed in one of the pervious questions in this chapter.

WsHttpBinding: - It is same like BasicHttpBinding. In short it uses SOAP over HTTP. But with it also supports reliable message transfer, security and transaction. Reliable message is supported by WS-ReliableMessaging, security with WS-Security, and transactions with WS-AtomicTransaction.

NetTcpBinding:- This binding Sends binary-encoded SOAP, including support for reliable message transfer, security, and transactions, directly over TCP. The biggest disadvantage of NetTcpBinding is that both server and client should be also made in .NET language.

NetNamedPipesBinding:-Ths binding Sends binary-encoded SOAP over named pipes. This binding is only usable for WCF-to-WCF communication between processes on the same Windows-based machine.

Note: - An interprocess control (IPC) protocol is used for exchanging information between two applications, possibly running on different computers in a network. The difference between Named pipes and TCP is that named pipes have good performance in terms of communication with in processes. But when it comes to communicate across network TCP holds the best choice. So if you are using WCF to communicate with process it's the best choice to use in terms for performance. Named pipes do not perform when the traffic is heavy as compared to TCPIP.

NetMsmqBinding:- This binding sends binary-encoded SOAP over MSMQ. This binding can only be used for WCF-to-WCF communication.

(A) Which are the various programming approaches for WCF?

(A) What is one way operation?

IsOneWay equal to true ensures that the client does not have to wait for the response. So methods marked by IsOneWay to true should always return void. In this the caller does

not get anything in return so it is called as one-way communication.

In order to understand one way implementation in WCF lets make a code walkthrough of a sample.

Note: - You can find code for the same in "WCFIsOneWay" folder in CD.

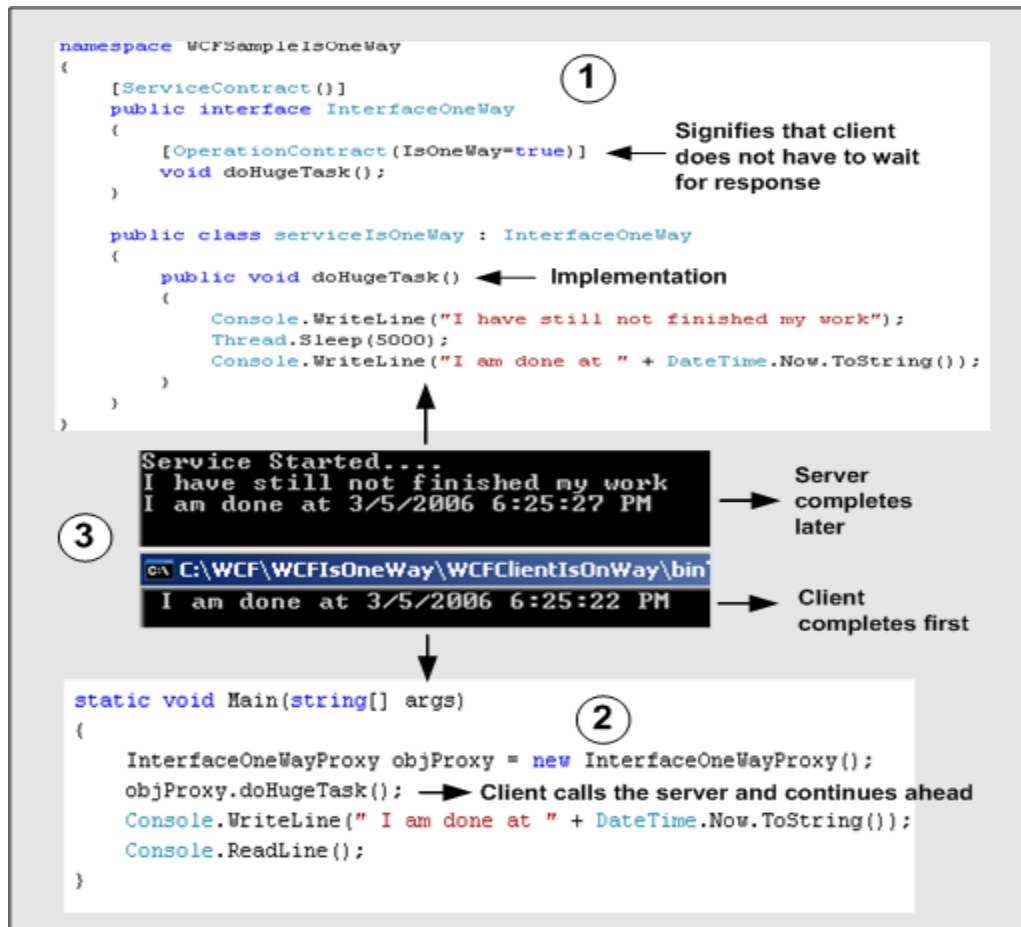

Figure 15.18: - One way in action

Above is the code snippet which describes practically how one way works in WCF. The above given code snippet is numbered. Below is the explanation according to the numbers marked in figure:-

1 - This is the code snippet of the server service. We have created a method called as doHugeTask. doHugeTask basically makes the method sleep for 5000 MS and then displays the time when the task is completed.

2 - This code snippet is for client. It creates a proxy object of serviceIsOneWay and calls the doHugeTask method. After calling the doHugeTask the client execution continues ahead. So as a proof we display the time when the method calling was completed.

3 - This screen shot shows the output given by both server and client. The top window displays the server output and the below windows displays the client output.

Note: - You can find the code for the same in WCFIsOneWay folder. For generating the proxies you have to follow the same steps which are shown in the previous steps.

So run the server program first i.e. ServiceIsOneWay and run the client later. You will see the client runs the doHugeTask and moves ahead. So the client completion time is less than the server. One more thing to understand is that one way does not give any notification back of completion. So it's like fire and forget.

(A) Can you explain duplex contracts in WCF?

In duplex contracts when client initiates an operation the server service provides a reference call back Uri back to the client. So the client initiates a call using the proxy class and when server finishes its work it notifies the client using the callback channel. This is called as duplex messaging in WCF. If you remember in the previous question we had no way to know when the server finished its task.

```

[ServiceContract (Namespace="http://WCFSampleDuplex", Session=true ,
    CallbackContract = typeof(InterfaceDuplexCallBack))] → 1
public interface InterfaceDuplex → 2
{
    [OperationContract (IsOneWay=true)]
    void doHugeTask();
}
public interface InterfaceDuplexCallBack → 3
{
    [OperationContract (IsOneWay = true)]
    void Completed();
}
[ServiceBehavior (InstanceContextMode=InstanceContextMode.PerSession)]
public class serviceDuplex : InterfaceDuplex → 4
{
    public void doHugeTask() → 5
    {
        Console.WriteLine("Called by client at " + DateTime.Now.ToString());
        Thread.Sleep(5000);
        Console.WriteLine("I am done at " + DateTime.Now.ToString());
        OperationContext.Current.GetCallbackChannel<InterfaceDuplexCallBack>().Completed() → 6
    }
}

<services>
  <service type="WCFSampleDuplex.serviceDuplex">
    <endpoint binding="wsDualHttpBinding" bindingConfiguration="DuplexBinding"
      contract="WCFSampleDuplex.InterfaceDuplex" />
  </service>
</services>

<bindings>
  <wsDualHttpBinding → 7
    <binding name="DuplexBinding" clientBaseAddress="http://localhost:8089/MyClient">
    </binding>
  </wsDualHttpBinding>
</bindings>

```

Specify the same in binding configuration

Figure 15.19:- Duplex Service code

Let's try to understand the duplex concept by doing a small sample. The code snippet is as shown in the above figure. We will extend the previous sample which was shown in the first question only that now we will provide the notification to the client once the doHugeTask is completed.

The first step is to change the service class. Above is the code snippet of the service class. Again we have numbered them so that we can understand how to implement it practically line by line. So below is the explanation number by number:-

1 -- In the service contract attribute we need to specify the callbackcontract attribute. This CallbackContract attribute will have the interface which will define the callback.

2 -- This is the interface which client will call. In order that it should be asynchronous we have defined the one way attribute on the doHugeTask method.

3-- This is the most important interface. As it forms the bridge of communication between server and client. The server will call the client using Completed method. Client needs to provide implementation for the completed method at the client side and server will call that method once it completes the doHugeTask method.

4 and 5 -- In this we implement the InterfaceDuplex interface and provide implementation for doHugeTask () method.

6 -- This is an important step. The OperationContext.Current.GetCallbackChannel will be used to make callback to the client.

7 - We will expose the service using HTTP protocol. In this sample because we want to do duplex communication we need to use wsDualHttpBinding rather than just using simple HttpBinding. This new binding configuration is then assigned to the end point on which the service is hosted.

This completes the server side explanation for duplex.

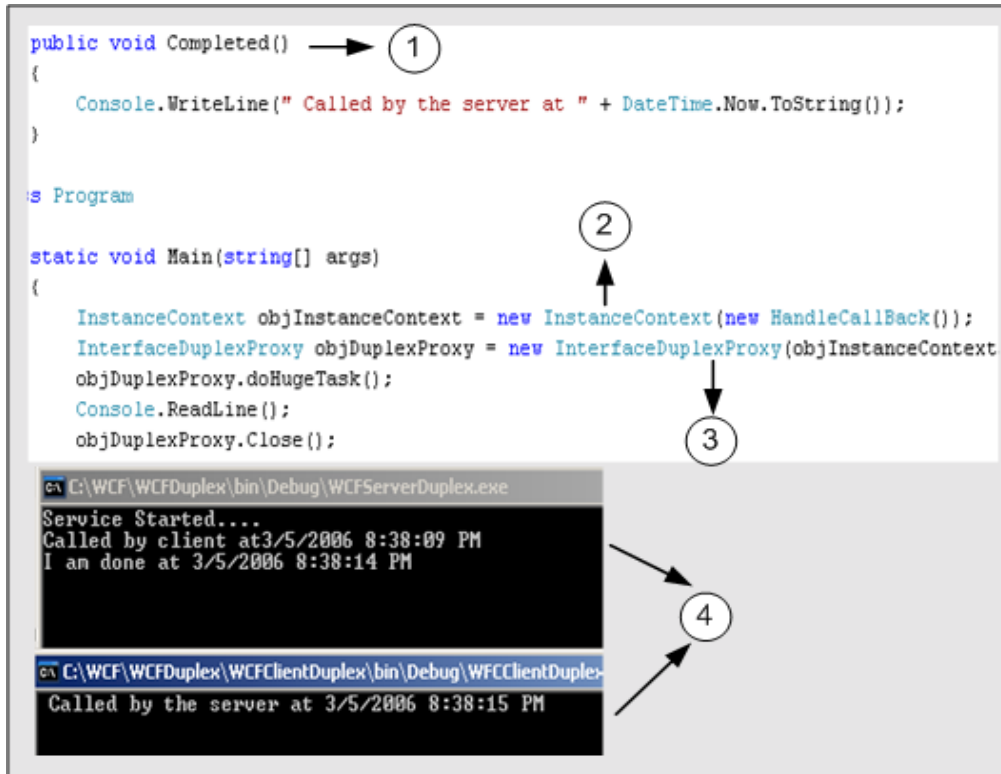

Figure: - 15.20 Duplex Client side code

Above is the code snippet for client side. So let's explain the above code with numbers.

- 1-- We implement the completed method. This is the callback method which the server will call when doHugeTask is completed.
- 2-- In this step we create object of the InstanceContext class. InstanceContext represents context information of a service. The main use of InstanceContext is to handle incoming messages. In short proxy is used to send messages to server and InstanceContext is used to accept incoming messages.
- 3 -- In this step we pass the InstanceContext object to the constructor of the proxy. This is needed as the server will use the same channel to communicate to the client.

4 -- In this section two windows are shown. The top windows is the servers output and the below windows is of the client. You can see in the below window that server as made a callback to the client.

Note: - You can get source code for the same in WCFDuplex folder. Feel Free to experiment with it. Try making one simple project of client to client that using WCF duplex fundamentals I am sure your doubts will be cleared in and out.

(A) How can we host a service on two different protocols on a single server?

Let's first understand what this question actually means. Let's say we have made a service and we want to host this service using HTTP as well as TCP. You must be wondering why to ever host services on two different types of protocol. When we host a service it's consumed by multiple types of client and it's very much possible that they have there own protocol of communication. A good service has the capability to downgrade or upgrade its protocol according the client who is consuming him.

Let's do a small sample in which we will host the ServiceGetCost on TCP and HTTP protocol.

Note: - You can the below sample in "WCFMultipleProtocolGetHost" folder in the CD provided.

Below is the code snippet pasted from the same sample. As usual we have numbered them and here is the explanation of the same:-

1 and 2 -- As we are hosting the service on two protocols we need to create two objects if the URI. You can also give the URI through config file. Pass these two objects of the URI in the constructor parameter when creating the service host object.

```
public static void Main()
{
    ServiceHost objServiceHost;
    Uri httpUri = new Uri("http://localhost:8088/servicemulti");
    Uri tcpUri = new Uri("net.tcp://localhost:8089/servicemulti");
    objServiceHost = new ServiceHost(typeof(serviceGetCost), tcpUri, httpUri);
    objServiceHost.Open();
    Console.WriteLine("Service Started...");
    Console.ReadLine();
}

<system.serviceModel >
  <services>
    <service type="WCFSampleGetCost.serviceGetCost">
      <endpoint binding="wsHttpBinding" contract="WCFSampleGetCost.IServiceGetCost" />
      <endpoint binding="netTcpBinding" contract="WCFSampleGetCost.IServiceGetCost" />
    </service>
  </services>
</system.serviceModel>
```

Figure 15.21:- Server side code for Multi Protocol hosting

3 – In the config file we need to define two bindings and end point as we are hosting the service in multiple protocols.

Once we are done the server side coding its time to see make a client by which we can switch between the protocols and see the results. Below is the code snippet of the client side for multi-protocol hosting.

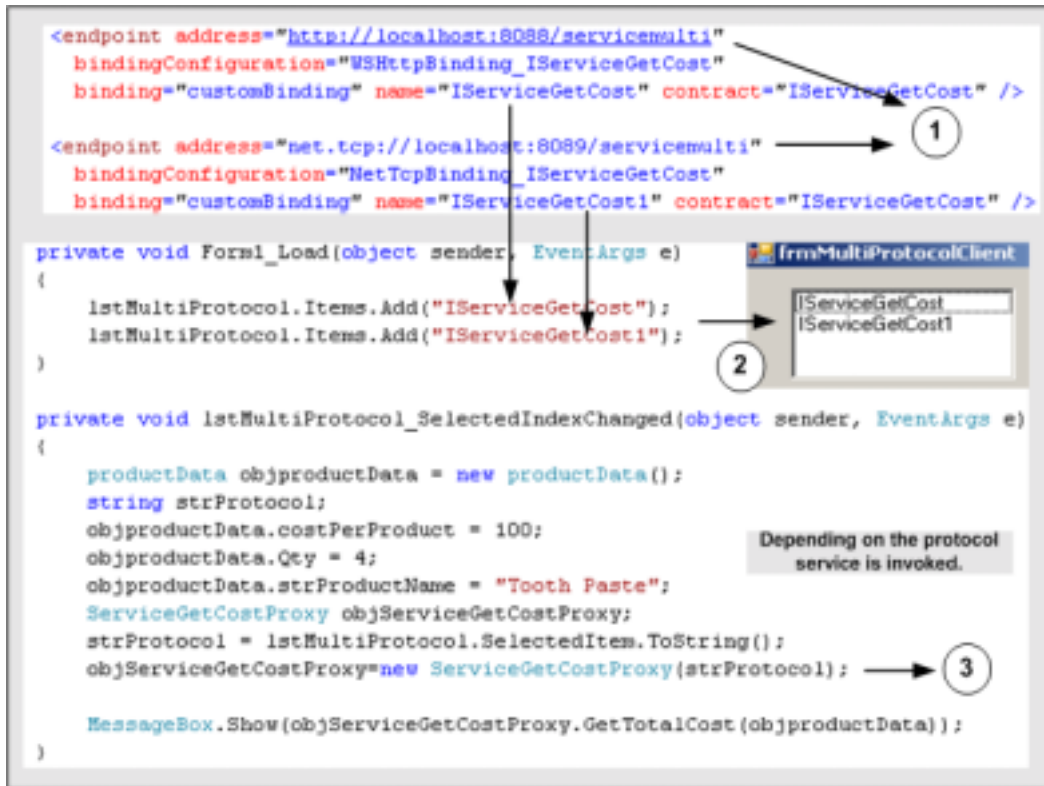

Figure 15.22:- Multi Protocol Client code

Let's understand the code:-

- 1 – In the generated config file we have added two end points. When we generate the config file it generates only for one protocol. The other end point has to be manually added.
- 2 – To test the same we have a listbox which has the name value given in the end point.
- 3 – In the listbox select event we have then loaded the selected protocol. The selected protocol string needs to be given in the proxy class and finally call the proxy class GetTotalCost.

(A) How can we use MSMQ bindings in WCF?

First let's understand why MSMQ came in to picture and then rest will follow. Let's take a scenario where your client needs to upload data to a central server. If everything will work fine and the server is available 24 hours to client then there are no issues. In case the server is not available the clients will fail and the data will not be delivered. There's where MSMQ comes in to picture. It eliminates the need of persistent connection to a server. So what you do is deploy a MSMQ server and let the clients post message to this MSMQ server. When your actual server runs it just picks up the message from the queue. In short neither the client nor the server needs to be up and running on the same time. In WCF we have a client and service model and in real world it's very much practical possible that both the entities will not be available at one time.

In order to use MSMQ you need to install the Message queuing by click on Install windows component and selecting MSMQ queuing. Once that done we are all set to make our sample of MSMQ using WCF.

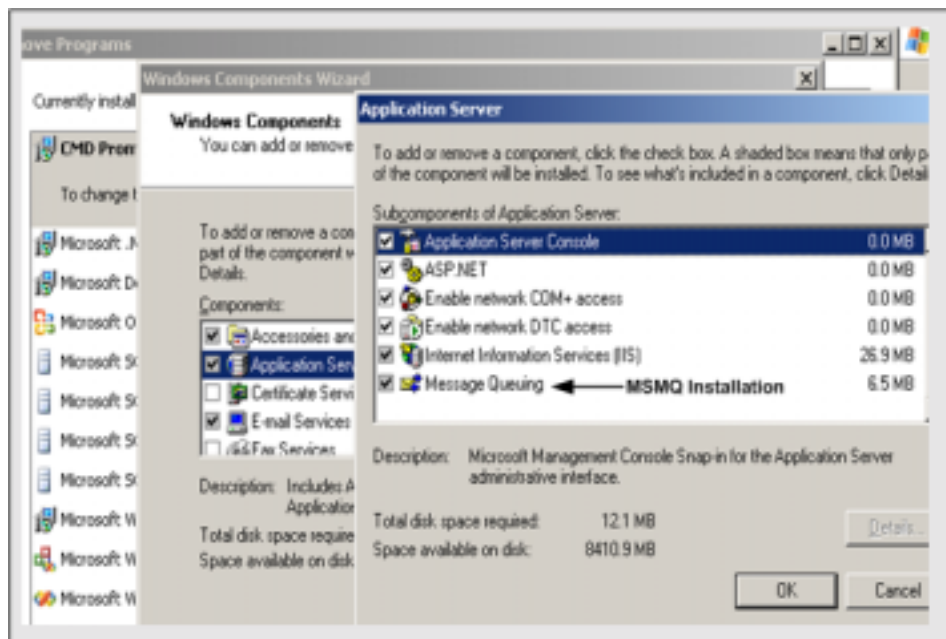

Figure 15.23 :- MSMQ Installation

This sample will be simple. We send some messages from the client and keep the server down. As the server is down it will make postings to the MSMQ server. Then we will run the server service and service should pick up the message and display the same.

Note: - You can find the sample code which we will be looking in to now in "WCFMSMQ" folder. Please note you need to first enable message queuing

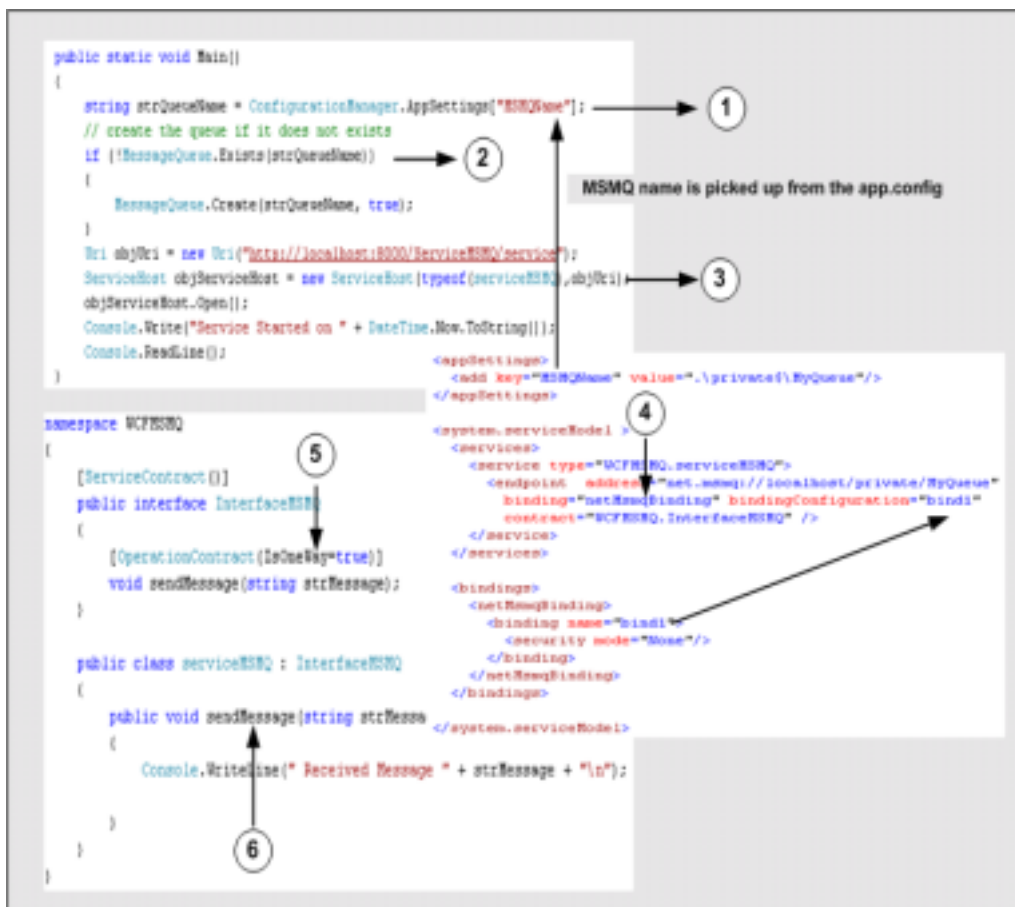

Figure 15.24:- MSMQ Server side code walkthrough

Above snippet is the server side code. So let's understand the whole snippet:-

1 – First thing is the queue name where the messages will go if the server is not running. The server name we can get from the config file. You can see in the above snippet we have defined the MSMQName in App.config file.

2 – We first check does this queue exist if it exists then go ahead. If not then go to create a queue. Please note you need import using System.Messaging namespace. Then we can use the Message Queue to create a queue if the queue does not exist.

3 – First thing which should surprise you is why we are creating a URI with HTTP protocol as we are going to use MSMQ. Ok!!! This is bit tricky but fun. As we know in order to connect to this service we need to generate a client proxy using SVCUTIL. So this URI will help us do that. It's not actually used by the client to connect.

4 – We need our end point and the MSMQ bindings.

5 and 6 – Again as usual we need is an interface and implementation for the same. In implementation we have created a method called sendMessage.

Once the above steps are executed run the server and generate the client proxy using SVCUTIL utility.

Now comes the final step making a client. One change you need to make is change the address to the MSMQ server in the app.config. In this we have just looped ten times and fired an offline message. Please note to keep your server down.

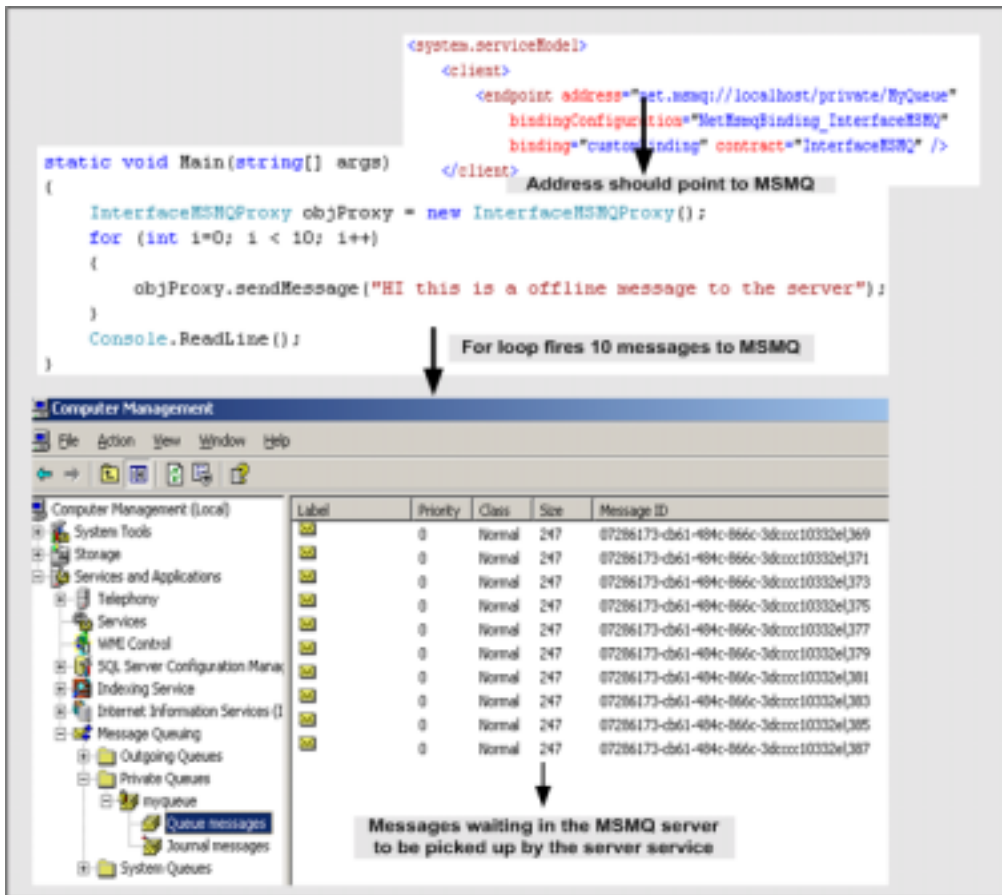

Figure 15.25:- MSMQ Client side code

Now go to computer management and you can see your queue messages waiting to be picked by the server. Run the server and below should be the output. If you come back again you will see that there are no messages in the queue.

```
CA C:\WCF\WCFMSMQ\bin\Debug\WCFServerMSMQ.exe
Service Started on 3/11/2006 6:47:25 PM Received Message HI this is
ssage to the server

Received Message HI this is a offline message to the server
Received Message HI this is a offline message to the server
Received Message HI this is a offline message to the server
Received Message HI this is a offline message to the server
Received Message HI this is a offline message to the server
Received Message HI this is a offline message to the server
Received Message HI this is a offline message to the server
Received Message HI this is a offline message to the server
Received Message HI this is a offline message to the server
```

Figure 15.26 :- MSMQ Server side display

One of the important concepts is to understand when to use MSMQ protocol. When we expect that client and server will not be available at one time this is the best option to opt for.

(A) Can you explain transactions in WCF?

(A) What different transaction isolation levels provided in WCF?

Transactions assure that a group of related activity occurs as a single atomic unit. In simple words, every activity in the unit must either all succeed or all should fail. WCF provides a central transaction system that can be used to handle transaction operations. One of the things WCF provides is a single unified transaction system for both database and non-database activity. For instance BeginTrans and CommitTrans are database related syntaxes but we can not use the same for other activities like if we want to upload all message in a single transaction to a MSMQ server. One thing to note is that WCF transaction abides to WS specifications. That means any other language like JAVA can take advantage of this transaction.... I think that's the best part of WCF embracing other languages.

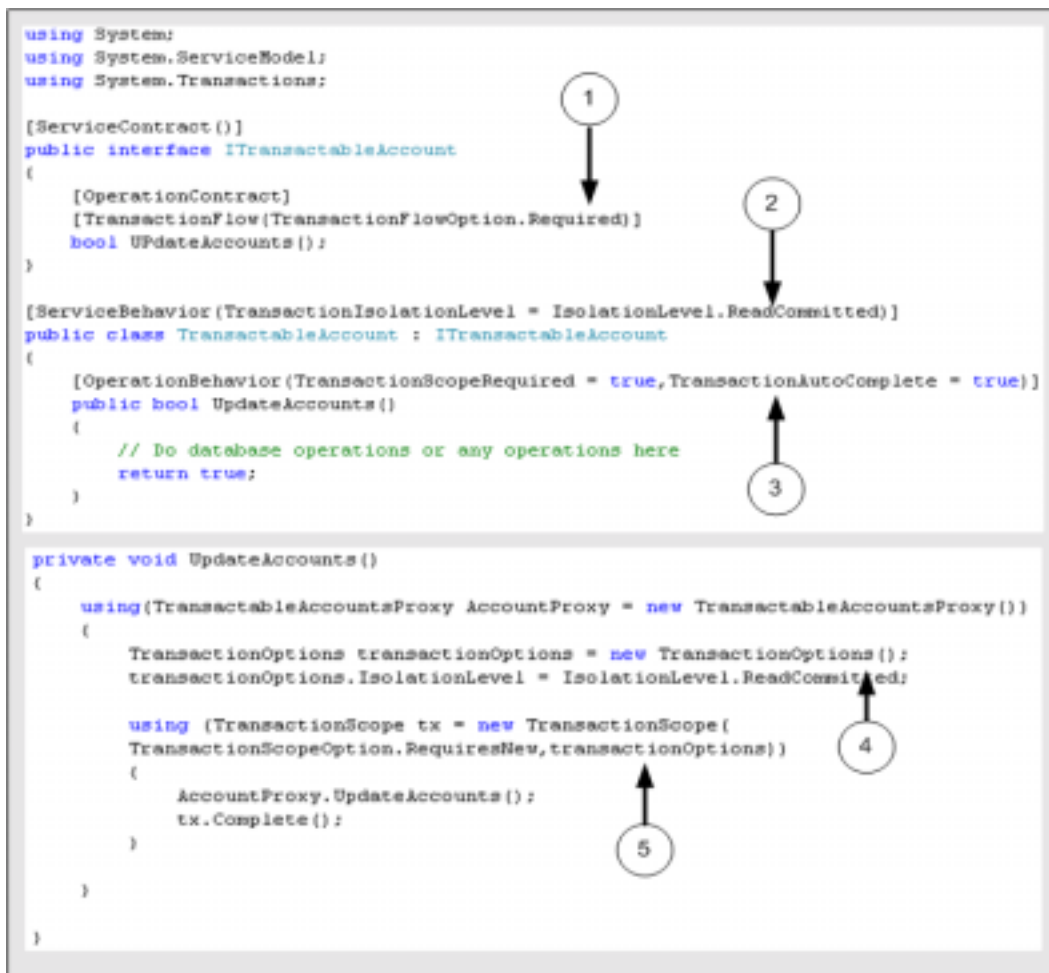

Figure 15.27 :- Transactions in WCF

In order to support transaction the service should first support transactions. Above is a simple code snippet of the server service and client and explanation for the same:-

The top code snippet is of the server service and the below code snippet is of the client.

1 - At interface level the operationcontract is attributed with [TransactionFlow] attribute. There are three values for it Allowed (which mean operation may or may not be used in transaction), NotAllowed (Where it's never used in transaction) and Required (Where the service can only be used in transactions). Below code snippet currently says that this service can only be used with transactions.

2 - In this section the [ServiceBehavior] attribute specifies the transaction isolation level property. Transaction isolation specifies the degree of isolation most compatible with other applications. So let's review what are the different levels you can provide in transaction isolation.

The data affected by a transaction is called volatile.

Chaos: - pending changes from more highly isolated transactions cannot be overridden.

ReadCommitted: - Volatile data can be modified but it cannot be read during the transaction.

ReadUncommitted: - Volatile data can be read as well as modified during the transaction.

RepeatableRead: - Volatile data can be read but not modified during the transaction and also new data can be added.

Serializable: - Volatile data can be only read. But no modifications and adding of new data is allowed.

Snapshot: - Volatile data can be read. But before modifying the data it verifies if any other transaction had changed data. If yes then it raises error.

By default, the System.Transactions infrastructure creates Serializable transactions.

3 - This defines the transaction behavior within the service. [OperationBehavior] has a property called as transactionscope. TransactionScope setting indicates that operation must be called within a transaction scope. You can also see TransactionAutoComplete is set to true which indicates that transaction will complete by default if there are no errors. If you do not provide the TransactionAutoComplete to true then you will need to call OperationContext.Current.SetTransactionComplete() to make the transaction complete.

Now let's make a walkthrough of the client side code for the service.

4 and 5 - You can see from the client we need to define Isolationlevel and the scope while making the call to our UpdateAccounts method.

(A) Can we do transactions using MSMQ?

While doing MSMQ there can be scenarios in the project where we would like either all the messages are uploaded to MSMQ or all messages read from MSMQ. After any message is read from MSMQ it's deleted from the queue. So some times this can be critical if there are exceptions in reading or uploading messages. As said before WCF transaction can be applied to database as well as other operations like MSMQ. So let's try to understand the same by doing a small sample.

Below is a numbered code snippet of MSMQ transactions.

1 - Sendmessage is the exposed method in the service. We have marked this method as TransactionScopeRequired=true

2 - On the client side we have use the transactionscope to say that we are starting a transaction to MSMQ server. You can see we have used the sendMessage to send the messages to MSMQ.

3- We can then use Complete or Dispose method to complete or rollback the transactions.

Note: - You can get the below sample code in WCFMSMQTransactions folder.

The below MSMQ transaction code ensures that either all messages are send to the server or none are sent. Thus satisfying consistency property of transactions.

```

namespace MCFMSMQTransactions
{
    Server side code
    [ServiceContract()]
    public interface InterfaceMSMQ
    {
        [OperationContract(IsOneWay=true)]
        void sendMessage(string strMessage);
    }

    public class serviceMSMQ : InterfaceMSMQ
    {
        [OperationContract(TransactionScopeRequired=true, TransactionAutoComplete=true)]
        public void sendMessage(string strMessage)
        {
            Console.WriteLine(" Received Message " + strMessage + "\n");
        }
    }
}

Client side code
InterfaceMSMQProxy objProxy = new InterfaceMSMQProxy();
using (TransactionScope objtrans = new TransactionScope(TransactionScopeOption.Required))
{
    for (int i = 0; i < 10; i++)
    {
        objProxy.sendMessage("HI this is a offline message to the server");
    }

    string stryesno = "";
    Console.WriteLine("Press y to commit");

    stryesno = Console.ReadLine().ToLower();
    if (stryesno.Equals("y"))
    {
        objtrans.Complete();
    }
    else
    {
        objtrans.Dispose();
    }
}

```

Figure 15.28:- Transaction snippet code

(A)Can we have two way communications in MSMQ?

Yes

(A) What are Volatile queues?

There are scenarios in the project when you want the message to deliver in proper time. The timely delivery of message is more important than losing message. In these scenarios Volatile queues are used.

Below is the code snippet which shows how to configure Volatile queues. You can see the bindingConfiguration property set to VolatileBinding. This code will assure that message will deliver on time but there is a possibility that you can lose data.

```
<appSettings>
  <!-- use appSetting to configure MSMQ queue name -->
  <add key="queueName" value=".\\private$\\ServiceModelSamplesVolatile" />
</appSettings>

<system.serviceModel>
  <services>
    <service name="Samples.StockTickerServ"
      behaviorConfiguration="CalculatorServiceBehavior">
      ...
      <!-- Define NetMsmqEndpoint -->
      <endpoint address="net.msmq://localhost/private/ServiceModelSamplesVolatile"
        binding="netMsmqBinding"
        bindingConfiguration="volatileBinding"
        contract="Samples.InterfaceStockTicker" />
      ...
    </service>
  </services>
```

```
<bindings>
  <netMsmqBinding>
    <binding name="volatileBinding"
      durable="false"
      exactlyOnce="false"/>
  </netMsmqBinding>
</bindings>
...
</system.serviceModel>
```

(A) What are Dead letter queues?

The main use of queue is that you do not need the client and the server running at one time. So it's possible that a message will lie in queue for long time until the server or client picks it up. But there are scenarios where a message is of no use after a certain time. So these kinds of messages if not delivered within that time span it should not be sent to the user.

Below is the config snippet which defines for how much time the message should be in queue.

```
<bindings>
  <netMsmqBinding>
    <binding name="MyBindings"
      deadLetterQueue="Custom"
      customDeadLetterQueue="net.msmq://localhost/private/
ServiceModelSamples"
      timeToLive="00:00:02"/>
  </netMsmqBinding>
```

(A) What is a poison message?

16. Windows Presentation Framework (Vista Series)

(B) What is WPF?

Windows Presentation Framework (Avalon was the code name for WPF) is the new presentation API in WinFX. WPF is a two and three dimensional graphics engine. It has the following capabilities:-

- √ Has all equivalent common user controls like buttons, check boxes sliders etc.
- √ Fixed and flow format documents
- √ Has all of the capabilities of HTML and Flash
- √ 2D and 3D vector graphics
- √ Animation
- √ Multimedia
- √ Data binding

(B) What is XAML?

XAML (pronounced as Zammel) is a declarative XML-based language by which you can define object and properties in XML. XAML document is loaded by a XAML parser. XAML parser instantiates objects and set there properties. XAML describes objects, properties and there relation in between them. Using XAML you can create any kind of objects that means graphical or non-graphical. WPF parses the XAML document and instantiates the objects and creates the relation as defined by XAML.

So XAML is a XML document which defines objects and properties and WPF loads this document in actual memory.

(I) what are dependency properties?

These are dependency properties that belong to one class but can be used in another.

Consider the below code snippet:-

```
<Rectangle Height="72" Width="131" Canvas.Left="74" Canvas.Top="77" />
```

Height and Width are regular properties of the Rectangle. But Canvas.Top and Canvas.Left is dependency property as it belongs the canvas class. It's used by the Rectangle to specify its position within Canvas.

(A) Are XAML file compiled or built on runtime?

XAML files are usually compiled rather than parsing on runtime. But it also supports parsing during runtime. When we build a XAML based project you will see it creates g.cs extension in obj\Debug folder. So for every XAML file you will find a g.cs file. For instance a Shiv.XAML will have Shiv.g.cs file in obj\Debug folder. In short in runtime you actually do not see the XAML file. But if you want to do runtime parsing of XAML file it also allows that to be done.

(B) Can you explain how we can separate code and XAML?

This is one of the most important features of WPF, separating the XAML from the code to be handled. So designers can independently work on the presentation of the application and developers can actually write the code logic independent of how the presentation is.

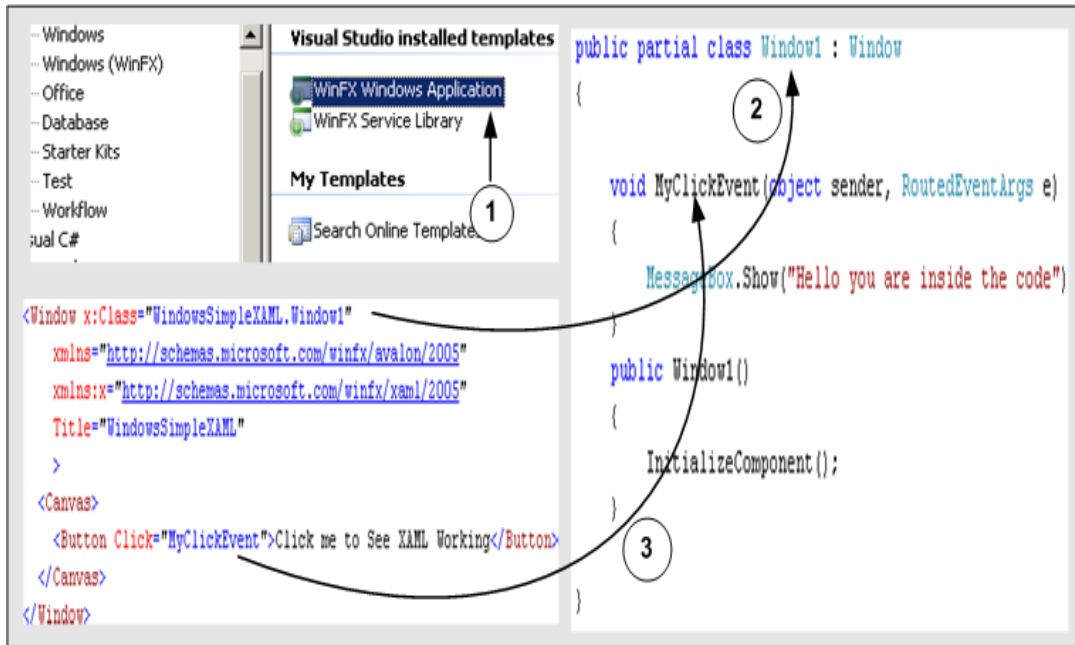

Figure 16.1:- XAML and behind code in action

Above is the code snippet which shows a XAML file and the code completely detached from the XAML presentation. In order to associate a class with XAML file you need to specify the x:Class attribute. Any event specified on the XAML object can be connected by defining a method with sender and event values. You can see from the above code snippet we have linked the MyClickEvent to an event in the behind code.

Note - You can get a simple sample in WindowsSimpleXAML folder. Feel free to experiment with the code... experimenting will teach you much more than reading something theoretical.

(B) How can we access XAML objects in behind code?

To access XAML objects in behind code you just need to define them with the same name as given in the XAML document. For instance in the below code snippet we named the object as objtext and the object is defined with the same name in the behind code.

```
<Canvas MouseEnter="ChangeValue" MouseLeave="ChangeValue1">
  <TextBlock Name="objText">Move your mouse on this </TextBlock>
</Canvas>

public partial class Window1 : Window
{
    public Window1()
    {
        Accessing the object by name
        InitializeComponent();
        objText = new TextBlock();
    }
    private void ChangeValue(object sender, EventArgs e)
    {
        objText.Text = "I am trying to learn XAML";
    }
    private void ChangeValue1(object sender, EventArgs e)
    {
        objText.Text = "XAML is easy to learn";
    }
}
```

The diagram illustrates the connection between XAML and C# code. Three vertical arrows point from the XAML code to the C# code. Arrow 1 points from the XAML element name 'objText' to the variable declaration 'objText = new TextBlock();'. Arrow 2 points from the XAML element name 'objText' to the property access 'objText.Text' in the 'ChangeValue' method. Arrow 3 points from the XAML event name 'ChangeValue1' to the method signature 'private void ChangeValue1(object sender, EventArgs e)'.

Figure 16.2 Accessing XAML object

Note: - You can get the source code in WindowsAccessXAML folder.

(A) What kind of documents are supported in WPF?

There are two kind of major document supported in WPF Fixed format documents and Flow format document. Fixed format documents look like PDF format. They display content regardless of screen size and resolution. But flow format document adjust depending on screen size and resolution.

Below is the code snippet for fixed format. You can see the document has a look of PDF reader. Step 1 defines the tag to define a document and Step 2 shows how the document looks.

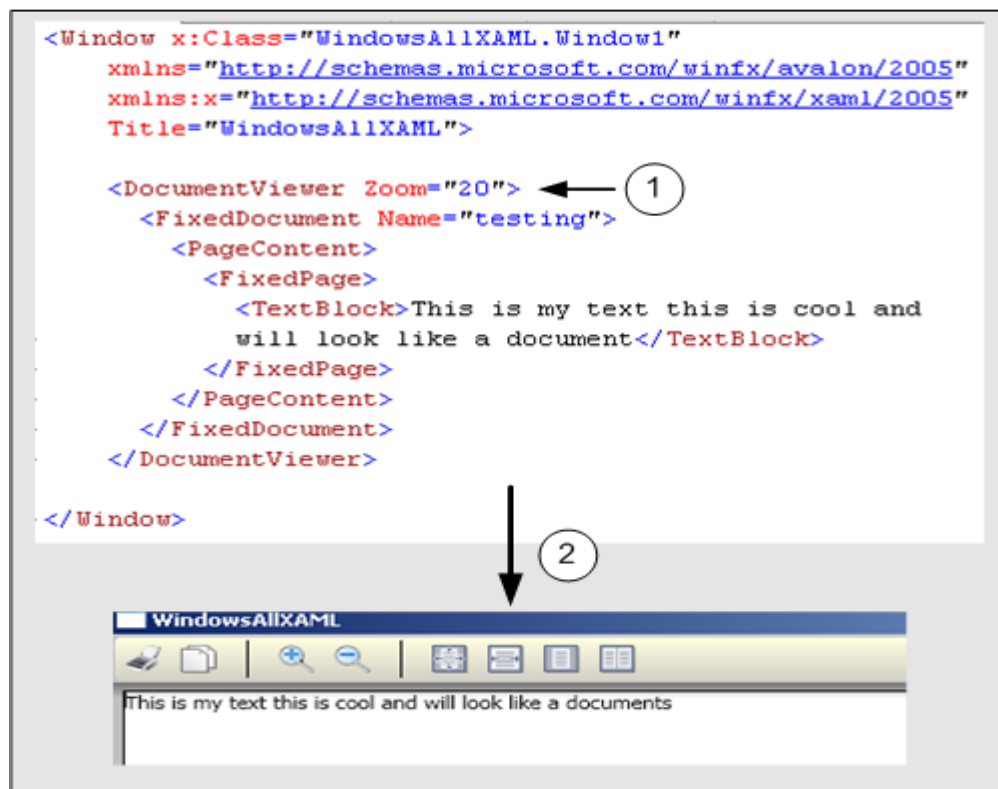

Figure 16.3:- Documentviewer in action

17. Windows workflow foundation(Vista series)

(B) What is Windows Workflow Foundation?

WWF is a programming model for building work flow enabled applications on windows. System.WorkFlow namespace has all the necessary modules to develop any type of work flow.

(B) What is a Workflow?

A Workflow is a set of activities which is stored as model and they depict a process. Below figure depicts clearly the difference between Workflow and Activity. Every task is an activity and group of activity depicts a complete workflow. Workflow is run by the Workflow runtime engine.

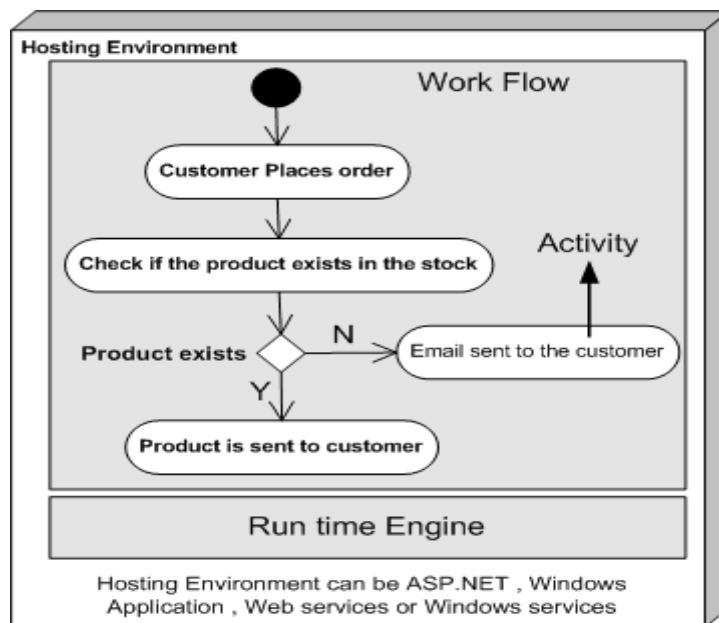

Figure 17.1: - Work Flow Foundation Architecture

Workflow model can be written either in pure .NET code, pure XAML or Mix of XAML and .NET Code. A workflow model is compiled and can execute under windows, ASP.NET, Web services or windows services application.

(B) What are different types of Workflow in Windows Workflow foundation?

There are two basics type of workflow Sequential Workflow and State machines workflow.

A sequential workflow has clear start and finish boundaries. Workflow controls execution in Sequential workflow. In sequential execution one task is executed after other. Sequential workflow is more rigid in format and execution path has a deterministic nature.

A State machine workflow is more dynamic in nature. Basically workflow has states and the state waits for events to help it move to next state. In State machine execution path is undeterministic nature.

Below figure shows visual conceptualization of fundamentals. You can see in Sequential work flow the execution path is very deterministic. Shiv performs the entire task sequentially and these tasks are very deterministic. But now have a look at the second work flow. Every state goes to other state when it receives some external events. For instance when Shiv is seeing star trek there is an event of flashing news which triggers him to see the flashing new.

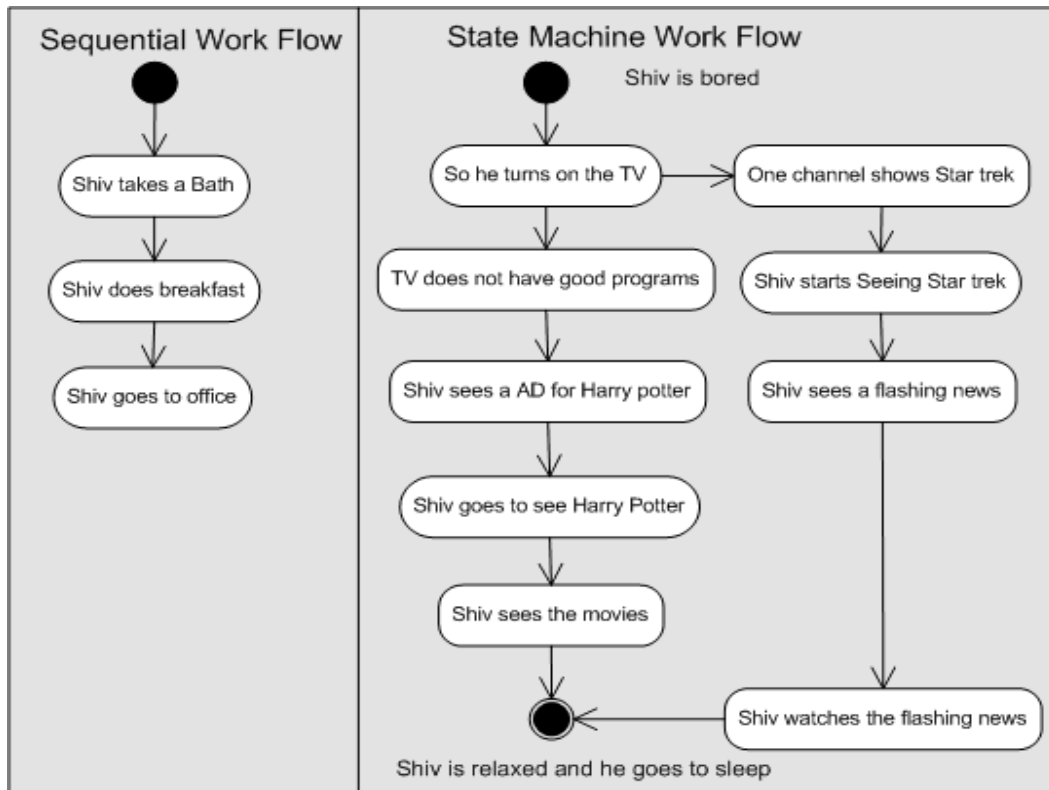

Figure 17.2: - Sequential and State machine work flow

(I) When should we use a sequential workflow and when should we use state machines?

If the workflow is very rigid then you go for sequential workflow and if the workflow is dynamic then go for State machine workflow. For instance you have placed an order and the order will not pass until your supervisor approves is a rigid flow. Because your order has to be approved by a supervisor or else it will not be approved. But what if your order moves from one place to other place. For instance it moves from approval to waiting and then clarification a state machine work flow model is more appropriate.

Below is a simple code snippet which shows practically how to use sequential work flow. Let try to understand step by step as marked in the figure:-

1 – First you need to select System.workflow namespace.

2, 3 and 4 – In these three steps we created code object and linked them with activity.

5, 6, 7 and 8 – We start the workflow and create workflow instance object to run the sequential workflow. You can see the output in 8. Depending on how you add the activity in section 3 it executes sequentially. Because we have added codeactivity1 first it executes the first activity first. The sequence on how you add the activity to the activities collection the activities are run.

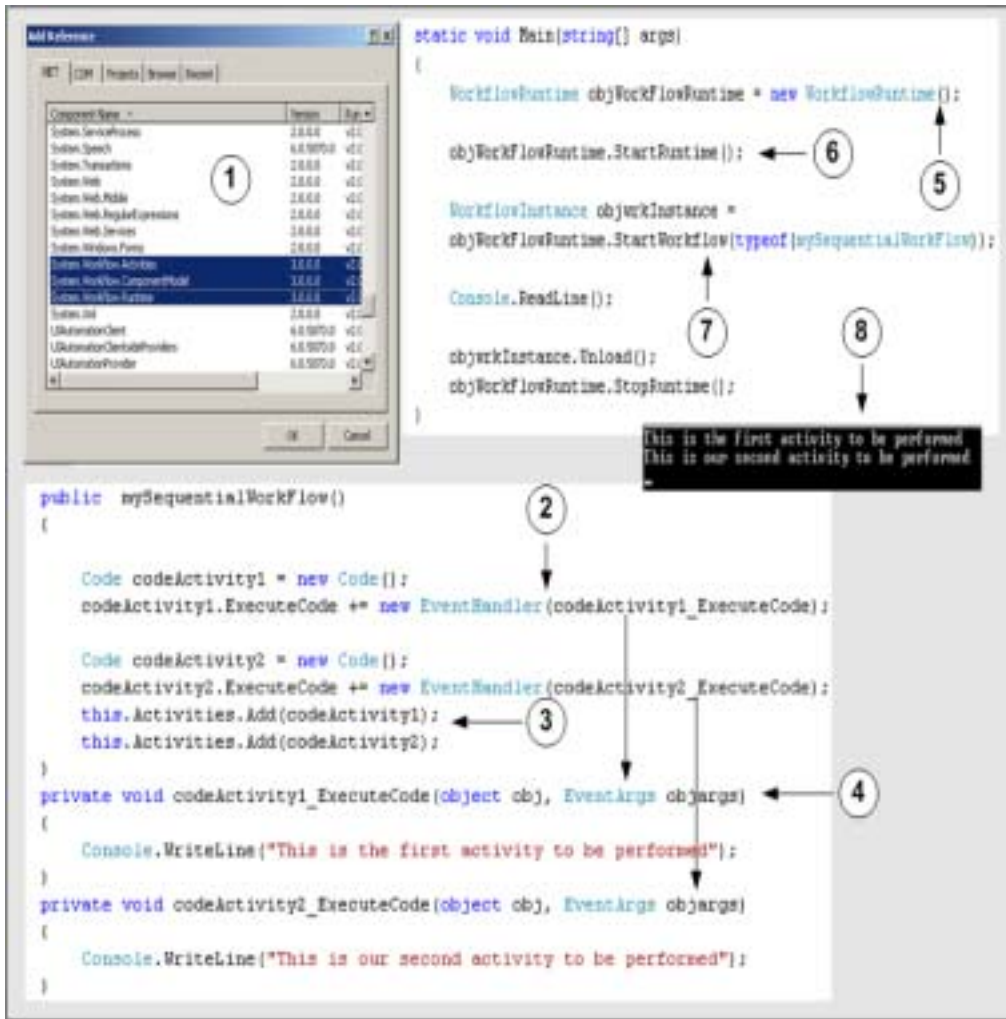

Figure - 17.3 Code snippet for workflow

Note - The above code snippet was developed with out using designer. The whole point was to make you understand what happens behind the scenes. In real projects you will be

dependent on designer rather than coding manually. You can find the above code in SimpleWorkflowSampleManual folder.

(I) How do we create workflows using designer?

As said previously it's very easy to design workflows using designer. So we will answer this question by actually doing a small sample. Below is the code snippet and image snapshot which shows how we can use the designer to create workflows. So let's understand all the below numbered snapshot.

1 -- First select a sequential workflow project. In this case we have selected Sequential workflow console application to keep the sample simple.

2 -- When you are done with creating the project you will see the solution explorer as shown in the second snapshot. There are two files one the WorkFlow1.cs and the other Workflow1.designer.cs. If you click on the WorkFlow1.cs you will get a designer pane as shown in snapshot 3. If you double click on Workflow1.designer.cs you will get behind code as shown in snapshot 4.

3 -- So let's drag drop a code activity on the workflow designer and associate this activity with a method called as MyActivity1. This association is done by entering the method name in ExecuteCode property. In MyActivity1 we have just displayed in the console that this is my first activity. Again we have added one more code activity which points to MyActivity2. If you see the designer pane we have sequenced code1 first and code2 next. So in short code1 will execute first and the code2. This is clear from the output displayed below.

4 - This is the behind code of the workflow.

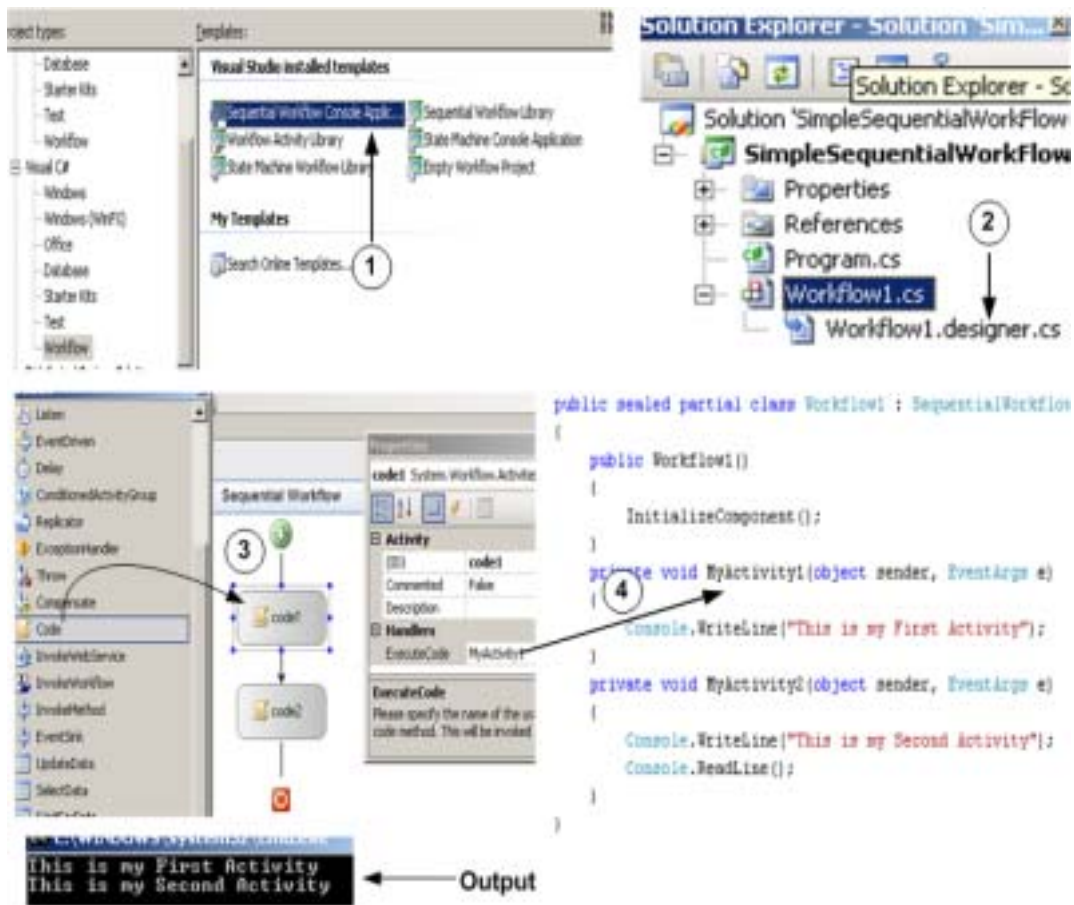

Figure 17.4 Sequential workflow using designer

Note: - You can find the above code snippet in SimpleSequentialWorkFlow folder.

(I) How do we specify conditions in Work flow?

Yes you can define conditions in workflow by using conditionedActivitygroup. Below is the numbered snapshot which shows how to use conditionedActivitygroup.

1 - You can see in this snapshot we have defined a `conditionedActivitygroup` with two conditions. The two boxes inside the group define two conditions.

2 - You can select one of the condition box and define the condition using the `WhenConditions` property. If this condition is true you need to specify in the execute code which method to execute. For instance in the current snapshot we have said that `old1` method should execute if `age > 21`. The same procedure we need to follow for the second condition box. In the second condition box we have specified to execute `young1` method if `age < 21`. Currently the second condition is not visible in the below snapshot.

3 - Workflow editor also provides a cool interface called as Rule Condition Editor which can be used to specify conditions. `Age` is a public property in the behind code. You can also get the `Age` in the intellisense of rule condition editor.

4 - Both the condition will execute inside the condition activity group. We need to also specify when this `conditionactivitygroup` should exit. So we have made a function called `exit`. If the user inputs `age` as `-1` it will exit from the loop or else it will take inputs from user and continue evaluating depending on the two conditions.

Note: - During interview the interviewer will not like to hear the complete story what I have said above. He needs only one word `conditionedActivityGroup` is used to specify conditions in workflow. The above story is just in case you also want to do some hands on practical. If you want to explore further you can get the above sample code in `SequentialWorkFlowConditions` folder.

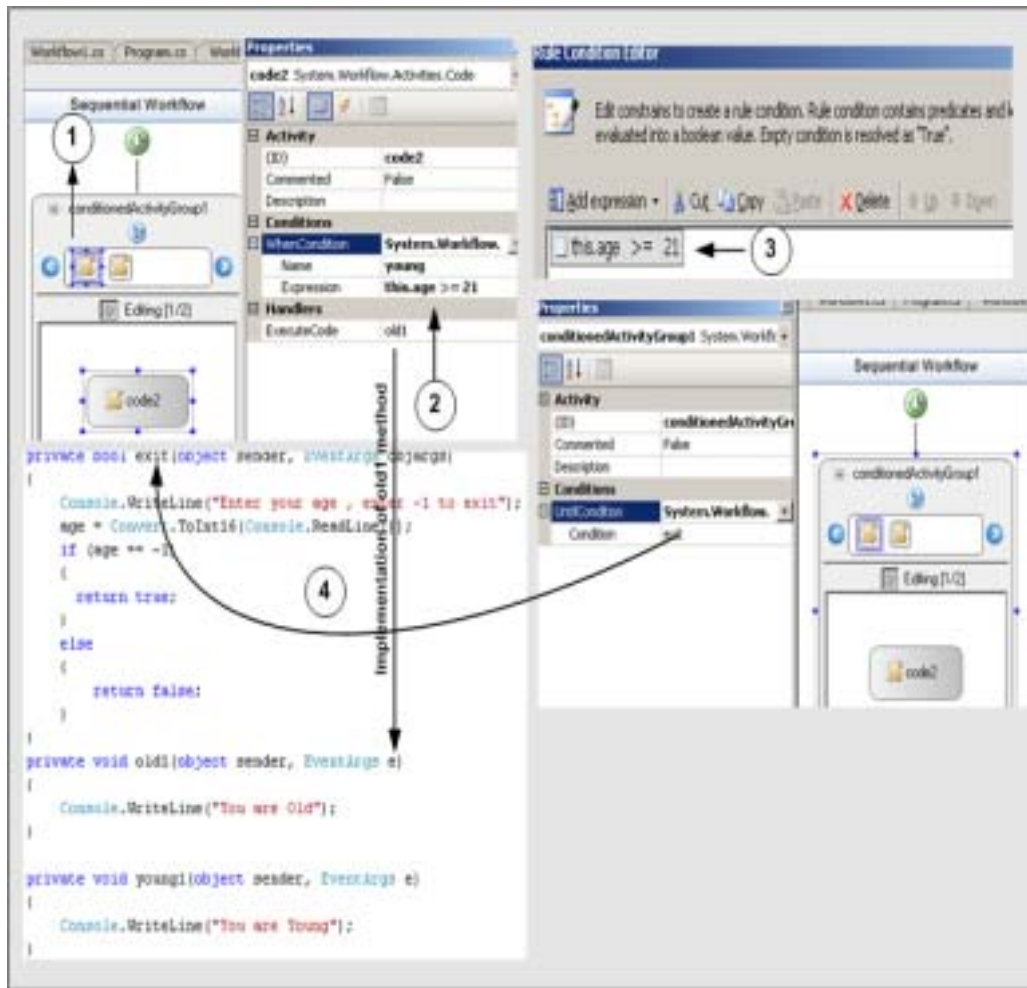

Figure 17.5:- Sequential workflow with conditions

(I) How do you handle exceptions in workflow?

Exception handling in Workflow is somewhat different than how we do in normal .NET application. Below is the numbered snapshot of how we can handle exceptions in Workflow.

-
- 1 - We have small tab which says view exceptions. If you click on view exception you will be redirected to a workflow design only for exception as shown in numbered snapshot 2.
 - 2 - This is the workflow which will execute incase we have exceptions. We have put a code activity which points to a method called as raiseException. Incase of exception in the workflow this path will be followed.

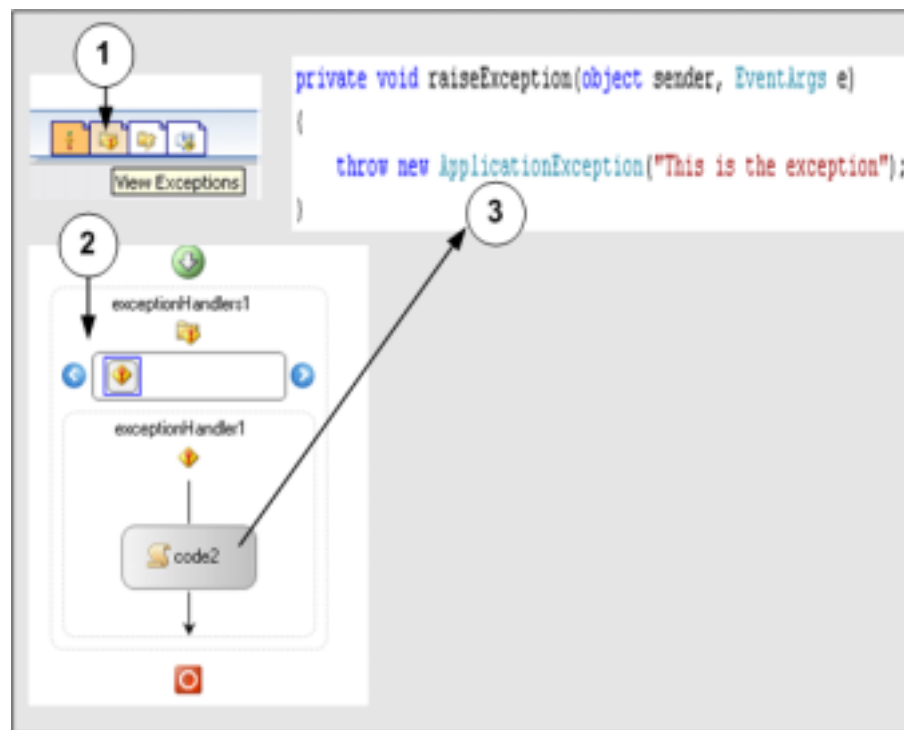

Figure 17.6:- Workflow with exception handling

(I) What is the use of XOML files?

Twist: - How can we serialize workflows?

Windows Workflow Foundation gives developers a declarative way to create workflows by using XAML. See WPF chapter for more details about XAML. These markup files are

stored with XOML (Extensible Object Markup Language) extension. In the below snapshot you can see Workflow1.xoml file created by designer. Markupfile can also have code behind. The whole concept of having code behind for XOML file is to separate the presentation from logic files.

In the below code snapshot we have made a simple XOML sample. Below is the explanation number wise:-

1 – In order to create a XOML file you need to add sequential workflow with separation. Which means that XOML file will be created with a behind code.

2 – Currently we have two activity code3 and code1. Below is the XOML file contents

```
<?Mapping XmlNamespace="ComponentModel"
ClrNamespace="System.Workflow.ComponentModel"
Assembly="System.Workflow.ComponentModel" ?>

<?Mapping XmlNamespace="Compiler"
ClrNamespace="System.Workflow.ComponentModel.Compiler"
Assembly="System.Workflow.ComponentModel" ?>

<?Mapping XmlNamespace="Activities" ClrNamespace="System.Workflow.Activities"
Assembly="System.Workflow.Activities" ?>

<?Mapping XmlNamespace="RuleConditions"
ClrNamespace="System.Workflow.Activities.Rules"
Assembly="System.Workflow.Activities" ?>

<SequentialWorkflow x:Class="WorkflowSeq.Workflow1 "
x:CompileWith="Workflow1.xoml.cs" ID="Workflow1" xmlns:x="Definition"
xmlns="Activities">

    <Code ExecuteCode="Mycode3" ID="code3" />

    <Code ExecuteCode="Mycode1" ID="code1" />

</SequentialWorkflow>
```

See the above snippet of the XOML file. You can see how the behind code is linked using the CompileWith attribute. Code forms the element of the SequentialWorkFlow tag. One of the best thing with Markup is we can change the sequence just by changing the XOML file we do not need to compile the whole application again.

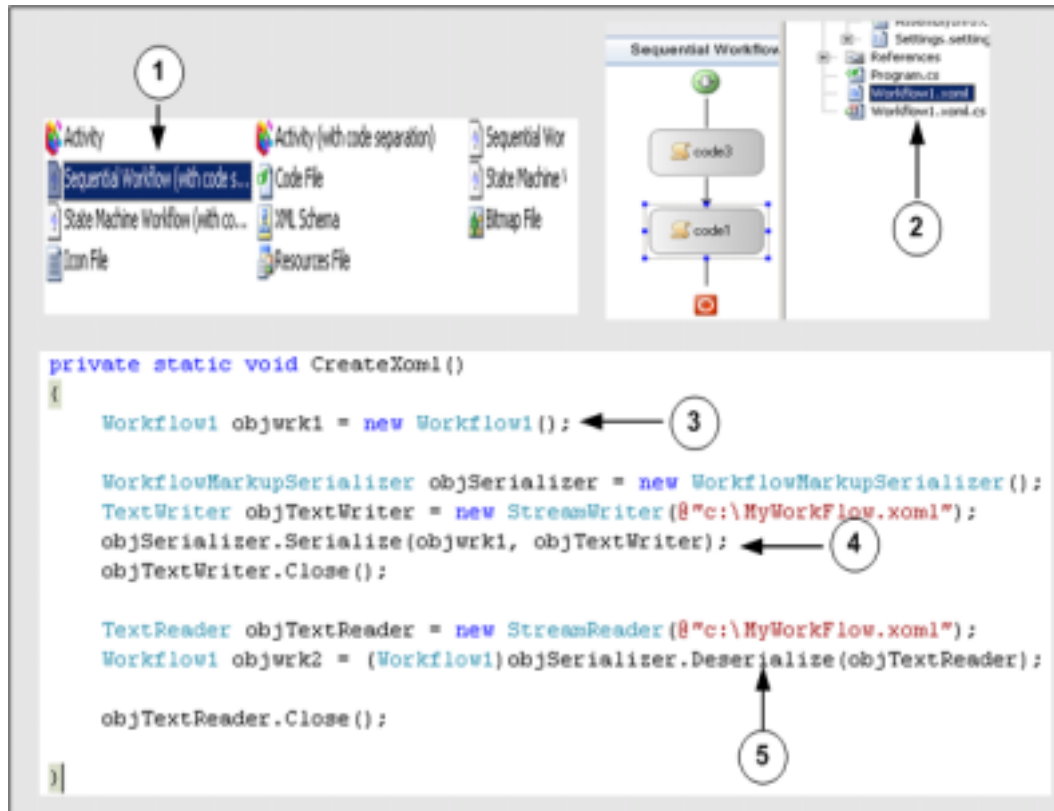

Figure 17.7:- XOML in action

In the above snapshot one of the things to now is 3, 4, and 5 numbered sections. These sections are not linked with the sample. But just to make you aware you can create serialize any workflow and deserialize them again using the textwriter object.

(A) How can we pass parameters to workflow?

When you call the startworkflow function you can pass as name / value pairs using the dictionary object.

```
WorkflowRuntime workflowRuntime = new WorkflowRuntime();
workflowRuntime.StartRuntime();

workflowRuntime.WorkflowCompleted += OnWorkflowCompleted;

Type type = typeof(SequentialWorkFlowConditions.Workflow1);
workflowRuntime.StartWorkflow(type, ...);
```

WorkflowInstance WorkflowRuntime.StartWorkflow (Type workflowType, Dictionary<string,object> namedArgumentValues)

Figure 17.8 :- Passing value to workflow

18 .ATLAS -AJAX

Note: - As an IT professional it's useful to know what the difference is between Hype and usefulness. For instance if there is a new technology coming in many programmers just want to implement it because they want to learn it?. But any new technology becomes useful if it is useful to the user. And Ajax is one of the technologies which will be useful as it really makes the user experience really good. You can get the atlas Ajax setup in CD.

(B) What problem does Ajax solve?

In order to answer this question first lets understand how does browser and server work when we request any website. Below figure depicts pictorially the web environment. When client sends data to the server it post backs form element data, hidden fields,images,cookie information to the server and server make the page and sends the same information back to the browser. The bad part this happens with every request and response.

Below are the issues with the above model:-

Unnecessary data transfers: - In the above model unnecessary data is transferred between client and server. For instance the whole page is posted and refreshed even when we want small data of the page to be refreshed.

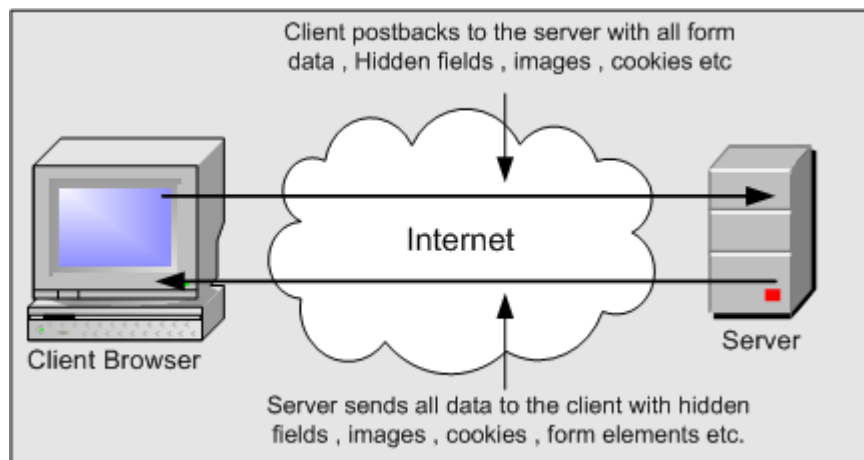

Figure 18.1:- The problem

Synchronous processing: - When a user request's for a page he has to wait until the complete round trip happens. In short the request / response work on a synchronous model rather than asynchronous which makes user experience very difficult. How many times it has happened that you are requesting a page and you see the below screen...frustrating right.

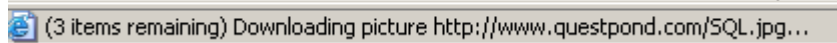

Figure 18.2:- Synchronous processing

Unnecessary processing by server: - Because we are posting unnecessary information to the server, the server is overloaded with unnecessary processing.

(B) What is Ajax?

Ajax is a set of client side technologies that provides asynchronous communication between user interfaces and web server. So the advantages of using Ajax are asynchronous communication, minimal data transfer and server is not overloaded with unnecessary load.

(B) What is the basic fundamental behind Ajax?

XmlHttpRequest is the basic fundamental behind Ajax. This allows the browser to communicate to a back end server asynchronously. XmlHttpRequest object allows the browser to communicate with server with out making post backs.

(B) What is JSON?

JSON is a very lightweight data format based on a subset of the JavaScript syntax, namely array and object literals. JSON allows communicating with server in a standard way. JSON is used as communication notation instead of XML.

```
var oBike =  
{  
    "color" : "Green",  
    "Speed": 200,  
};
```

```
alert(oBike.color); //outputs "Green"
```

```
alert(oBike.Speed); //outputs 200
```

The above code creates an object bike with two properties Color and Speed.

(B) How do we use XMLHttpRequest object in JavaScript?

Below is a code snippet which shows how to use XMLHttpRequest object. In this code snippet we are sending a GET request on the local IIS. Below is the explanation of the code snippet according to the numbers specified in the code snippet.

1,2,3,4 - This is like checking which is this browser and create the objects accordingly. XMLHttpRequest objects have different ways of technical implementation according to different browsers. In Internet explorer it's an activex object but in other browsers its XMLHttpRequest. So if windows.XMLHttpRequest does not return null then we can create XMLHttpRequest object. If it returns null then we can try creating the activex object Microsoft.XMLHttp object. In case it fails probably then probably we have an older version of XML that is MSXML2. So in the error handling we will try to create the MSXML2 object.

5:- In this snippet we OPEN the connection to the local host server and specify what type of request we are using. In this case we are using the GET method.

6:- Finally we make a request to the server.

7:- Here we get the request sent by the server back to the client browser. This is a blocking call as we need to wait to get the request back from the server. This call is synchronous that means we need to wait for the response from the server.

```
<script language="javascript">
sendXMLHttpRequest();

function sendXMLHttpRequest()
{
var xmlHttpObj;
if(window.XMLHttpRequest) ← 1
{
xmlHttpObj = new XMLHttpRequest(); ← 2
}
else
{
try(xmlHttpObj = new ActiveXObject("Microsoft.XMLHTTP");) ← 3
catch(e)
{xmlHttpObj = new ActiveXObject("Msxml2.XMLHTTP");}
}
xmlHttpObj.open("GET", "http://localhost/", false); ← 4
xmlHttpObj.send(); ← 5
alert(xmlHttpObj.responseText); ← 6
}
</script> ← 7
```

Figure 18.3:- Basic XMLHttpRequest code

(B) How do we do asynchronous processing using Ajax?

xmlHttpObj.onreadystatechange = function1();

Above is the code snippet which will help us to do asynchronous processing. So function1() will be called when the XMLHttpRequest object goes to on ready state change.

(B) What are the various states in XMLHttpRequest and how do we check the same?

(B) How can we get response text?

(B) How can we send request to the server using the XMLHttpRequest component?

Note :- All the above answers are discussed in detail in the below section.

`abort()` :- This method cancels a user request.

`getAllResponseHeaders()` :- Returns a collection of HTTP headers as string. If you want a specific header value you can use `getResponseHeader("headername")`

`open("method", "URL", "async", "uname", "pswd")` :- This method takes a URL and other values needed for a request. You can also specify how the request is sent by GET, POST or PUT. One of the important values is how this request will be sent asynchronously or synchronously. `true` means that processing is carried after the `send()` method, without waiting for a response. `false` means that processing is waits for a response before continuing.

`send (content)`:- Sends a request to the server resource.

`setRequestHeader("label", " value")` :- Sets label value pair for a HTTP header.

`onreadystatechange` :- This is a event handler which fires at every state change.

`readyState` :- Returns the current state of the object.

0 = uninitialized

1 = loading

2 = loaded

3 = interactive

4 = complete

If you want to check the state use `if (xmlhttpObj.readyState ==4)`.

`responseText` :- Returns the response in plain string.

`responseXML` :- Returns the response as XML. So this gives us DOM object model which can then be traversed.

`status` :- Returns the status as a numeric For instance 404 for "Not Found" or 200 for "OK", 500 for "Server Error" etc.

statusText :- Returns the status as a string. For instance "not found" or "OK".

(I) How do we pass parameters to the server?

Below are the two ways of passing data to server. The first one shows by using GET and the second by POST.

```
xmlHttpObj.open("GET", "http://" + location.host + "/XmlHttpExample1/  
WebForm1.aspx?value=123", true);
```

```
xmlHttpObj.open("POST", "http://" + location.host + "/XmlHttpExample1/  
WebForm1.aspx?value=123", true);
```

(I) How can we create a class in JavaScript using Atlas?

Note: - You can get the atlas setup in CD in "Atlas setup" folder.

JavaScript is object based language and this a new feature which is provided by Atlas. Using Atlas you can now define classes, do inheritance, create interfaces etc in JavaScript. You can now implement all the object oriented concepts in JavaScript. So let's understand the same with an example.

Once you install the Atlas setup you will get the following JS files and a web.config file as shown in the below figure. In order to use Atlas you need to add the JS files in your project. You can see from the figure below we have added the JavaScript files and the web.config file to the project which was installed with Atlas setup. We also need to add Microsoft.Web.Atlas.dll to the project. Components.js has the class definition which we will discuss in the coming sections.

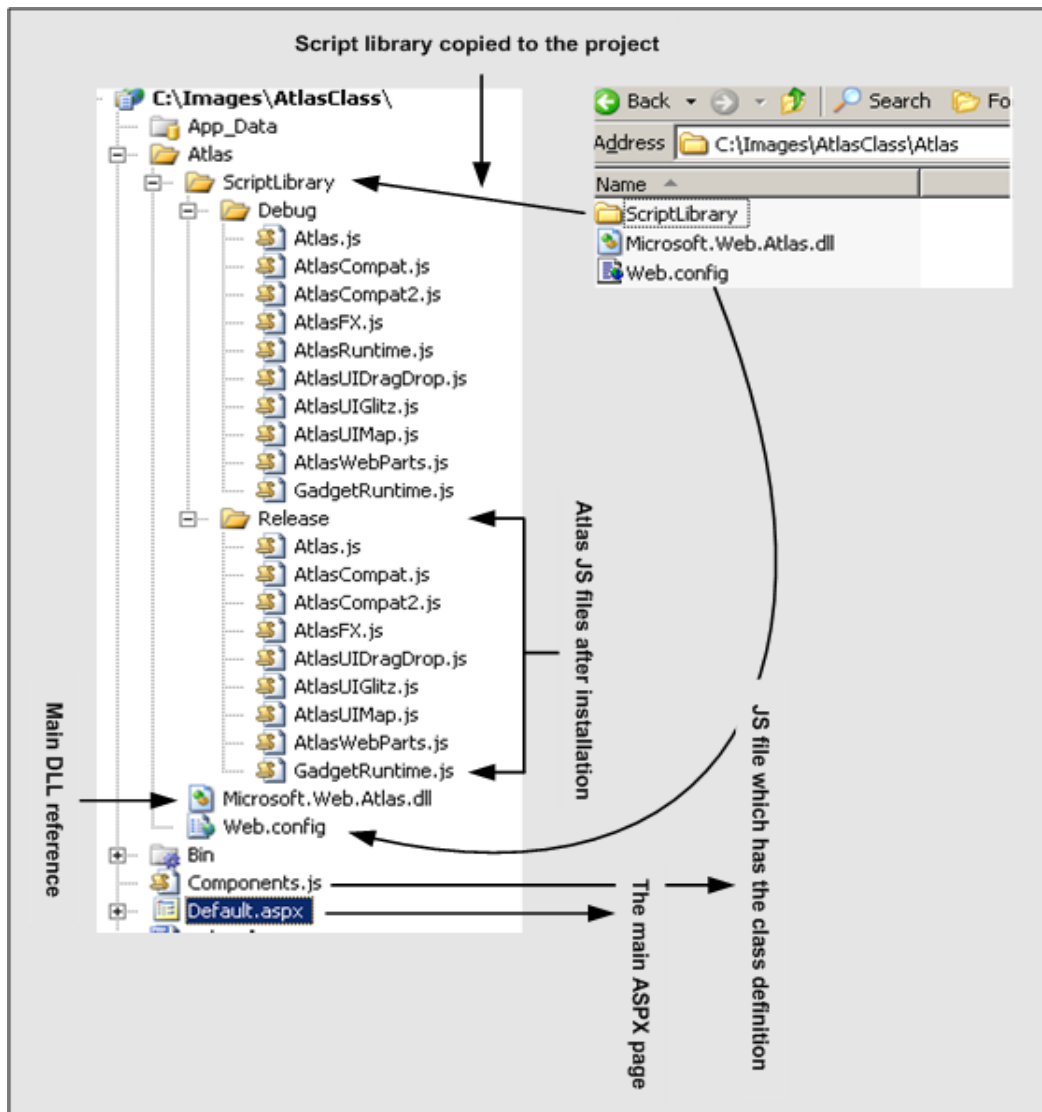

Figure 18.4:- Ajax folder structure

Below figure has two important code snippets the top one is taken from components.js it defines the class definition and the second code snippet is of ASPX page which consumes the JavaScript class. So let's understand all the numbered points one by one.

1 - In this section we register namespace using registerNameSpace function. We have named our namespace as NameSpaceCustomer.

2 - Here we have defined our class clsCustomer.

3 - We have defined two properties Customer Code and Customer Name. Both the properties have get and set function. We have also defined a read-only function getCodeAndName which returns the concatenation of customer code and customer name.

4 - Finally we register the class with the namespace.

5 - In this section we have consumed the class.getCodeAndName will display the concatenated value of customer code and customer name.

Note: - You can find the above code in AtlasClass folder. Feel free to experiment with the same.

```

// JScript File
registerNamespace("NameSpaceCustomer"); ← 1
NameSpaceCustomer.cisCustomer =function()
{
  var m_CustomerCode='';
  var m_CustomerName='';

  this.get_CustomerCode = function(){return m_CustomerCode;} ← 3
  this.set_CustomerCode = function(value){m_CustomerCode=value;}

  this.get_CustomerName = function(){return m_CustomerName;}
  this.set_CustomerName = function(value){m_CustomerName=value;}

  this.getCodeAndName = function(){alert(m_CustomerCode + ' : ' + m_CustomerName);}
  this.dispose = function(){alert('This will be your clean up code');}
}
NameSpaceCustomer.cisCustomer.registerClass('NameSpaceCustomer.cisCustomer',
null,
Sys.IDisposable);
↑
4 Consuming the class in aspx page
↓
<form id="form1" runat="server">
  <atlas:ScriptManager ID="ScriptManager1" runat="server" />
  <div>
  </div>
</form>
<script language="javascript" type="text/javascript" src="Components.js">
</script>
<script language="javascript">
  Check1();
  function Check1()
  {
    var obj = new NameSpaceCustomer.cisCustomer(); ← 5
    obj.set_CustomerCode('Cust001');
    obj.set_CustomerName('Koirala Enterprises');
    obj.getCodeAndName();
  }
</script>

```

Figure 18.5:- Code snippet for consuming the class

(A) How do we do inheritance using Atlas?

(A) How do we define interfaces using Atlas?

Below is a numbered code snippet which will answer both the upper questions. Lets understand in detail the numbered sections.

1 and 2 -- This defines the interface definition. `Function.abstractMethod()` defines a method as abstract.

3 - We need to register the interface which is done by using `registerInterface` method.

4, 5 and 6 - Inheritance and Interface is defined when we register the class. `registerClass` has three inputs. 4th section defines the main class which needs to be registered. 5th section defines the parent class from which it will inherit. 6th section defines the interface. So `clsMyCustomCustomer` is the class which derives from `clsCustomer` and implements `ICustomer` interface.

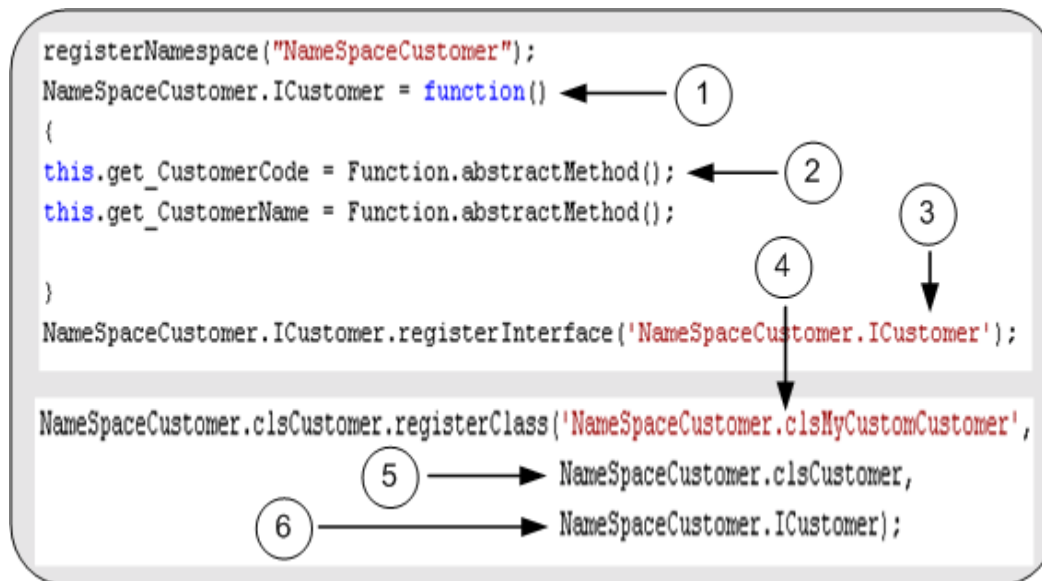

Figure 18.6 :- Inheritance and Interfaces in action

(A) How do we reference HTML controls using Atlas?

```
<input id="Button1" type="button" value="button" />
```

You can reference the above HTML defined button using the below code snippet of JavaScript. We have also attached the onClick method with the button. This method will be called when we click the button.

```
var btnVisibility = new Sys.UI.Button($('Button1'));  
btnVisibility.initialize();  
btnVisibility.click.add(onClick);
```

You can refer other HTML elements like Label, Textbox m CheckBox , Hyperlinks etc using the Sys.UI.

Note: - Atlas is itself very huge. For the current book edition in the remaining section we will just go through the questions. I will be answering them in the fourth edition because of bandwidth. So guys till then try answering them yourself and send them across to me so that I can be also benefited.

Can you explain server controls in Atlas?

Can you explain ScriptManager control?

What is the importance of UpdatePanel Control?

Can you explain update progress control?

Can you explain control extenders?

How can we data binding in Atlas?

Can you explain AtlasUIGlitz library?

I want to create a project like Google maps how can we do that with Atlas?

How can we integrate Atlas with Web services?
How can implement drag and drop using Atlas?
How do we do authentications using Atlas?
How can we access profiles using Atlas?
How can we access dataset in Atlas?
We have custom data type on a web service how do we access the same in Atlas?

19. Sample Projects

A good practical project is equivalent to this whole book – Shivprasad Koirala (just kidding). In this chapter I will give some samples which you can practice for yourself. But the motto behind these projects is not only to give you sample projects to complete but the way you can approach to complete these projects. We will be completing the address book application and finally you can get the full source in CD.

Note: - If you are looking for how big multinationals approach to complete software projects then buy my book “C# Projects” from BPB publications. Mail bpb@vsnl.com for more details.

There are four projects which I have outlined:-

- √ Address book
- √ Mini-Job Site
- √ Chat Application
- √ Reminder application

Approach to complete the projects

First thing coding is not everything in software world. They form the smallest part of the project. So for the above four projects I am not expecting you to only give me source code but lot of other artifacts (documents) also.

For all the projects above I have given you prototype look which can be useful in assisting to get clarity. Do not take the looks from the prototype as the final one it can change but the data elements should not change. For instance the edit is hyperlink according to the prototype but in actual implementation it can be a button.

Below are expected documents for the projects discussed:-

- √ Estimation document: - The first step in all the below project is an estimation document. In how much time do you expect the project to be completed? You can express the estimated figure in ‘man / days’ or ‘man / hours’. So use one of the standard estimation methodologies like Function points, Use Case points or WBS to estimate the project. If you do not know what these estimation methodologies are see project management chapter for the same. Do not forget to put an assumption section in the estimation.

-
- √ Project Management plan document: - Once you know what the estimates are to complete the project we need to make detail project management plan (PMP document) for the same. You can use softwares like Microsoft project or even a simple word and excel will do. For details of PMP document see Project Management chapter for more details.
 - √ Use Case Document: - From the given scope and screen shots write Use Case documents which will define the exact flow with actors, roles and scenarios. See UML for what a Use Case document is?
 - √ Technical Design document: - Once the Use Case document is done start with the technical document. Normally technical document use UML a lot. Look in to UML chapter for more details. But from the above project point of view I need the following things in the technical document for clarity sake :-
 - √ ER diagram (Which shows us the database diagram).
 - √ Class diagram.
 - √ Interaction diagram
 - √ Pseudo-code
 - √ Test plan: - This is normally done by the testing department. But just for practice write test plans with steps and expected results. The above test plan will be executed after the code complete.
 - √ Coding standard document: - This document will decide what naming conventions will be followed through out the project i.e. Database, variable declaration, class file naming conventions etc. For instance for database table objects you can have naming convention like “tbl_group_actualobject” ? “tbl_accounts_inventory”. What will be your commenting standards? For instance programmer name, changes made, date when the changes where made etc.
 - √ Source code: - Finally the source code with commenting standards and naming standards as defined in the coding standard document and according to the use case.

I have given the approach and documents I expect. But how to go about it is all up to you guys. You are free to decide which is the best approach for this project windows or web, three tier or one tier, database access or sql server, VB.NET or C# etc .

So if you are able to finish any of the projects with these seven documents ZIP everything and send it to me. I can check and verify if it has followed everything properly. Please

send all you documents zipped at shiv_koirala@yahoo.com . I will review and send in the comments to you back. My main concern will be on how you approach rather than just the code. Definitely I will like to see the code working but the approach will be reviewed more in detail rather than just implementation.

I am sure if you do these projects yourself with all the above documents in place you will be at very good position to face any big company interview with confidence.

Address book

EST sales private limited grew by 3 million dollars this year. EST deals with selling mineral water in bulk to commercial premises. All customer information is maintained till today in excel document. But maintaining data in excel had the following issues:-

- √ No provision for avoiding duplicate customer data. All customers are uniquely identified by phone numbers but it was becoming tedious to avoid duplicate customer data.
- √ Customer information was not so secured, anyone can easily copy the excel sheet.

Looking at the above two points EST decided to make a small address book application. Below is the prototype of the “Address book” application.

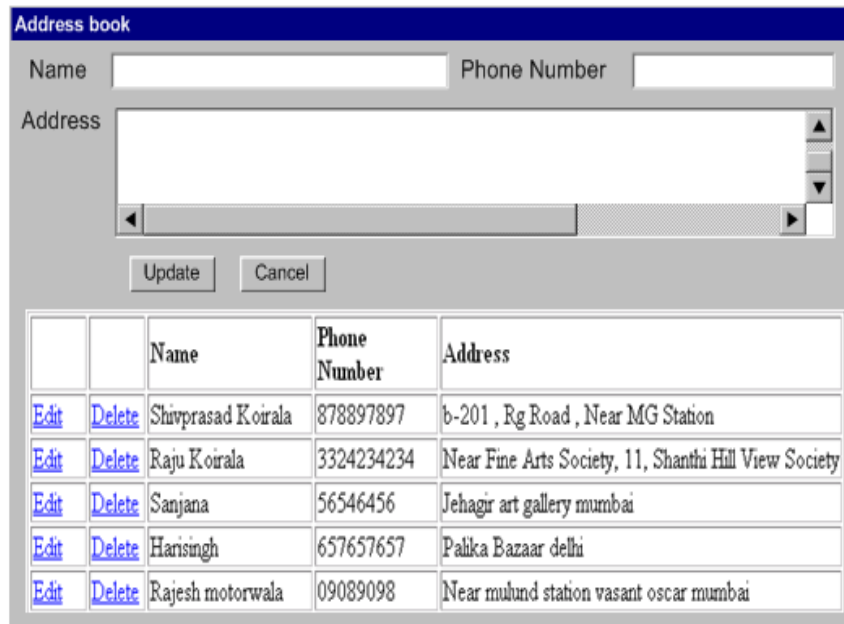

Figure 19.1 : - Address book

Currently EST is interested only in three prime data Name, Phone and Address. This address book will only be a windows application with only one screen as shown above. Grid below will display the necessary customer information with a “Delete” and “Edit” option. When EST staff want to add any new customer they will fill all three details and click “Update” button. As soon as the customer data is entered the below grid will be flourished. User can click on the “Edit” link to change customer information if necessary. User can also click on the “Delete” link to remove the customer data permanently from the database. When user clicks on the “Delete” link user will be prompted to confirm that is he sure to delete the customer information from the database.

Mini-job site

Note: - This is one of the largest projects so if you think you are not comfortable do not attempt this. You can keep this as last project to practice.

Mini-job site is a job site which brings together job seekers and companies. It has the following five important functionalities:-

√ Login module.

This module ensures that only registered users can enter the job site.

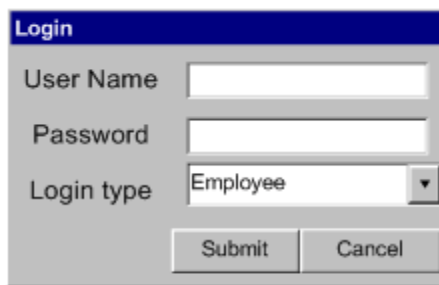
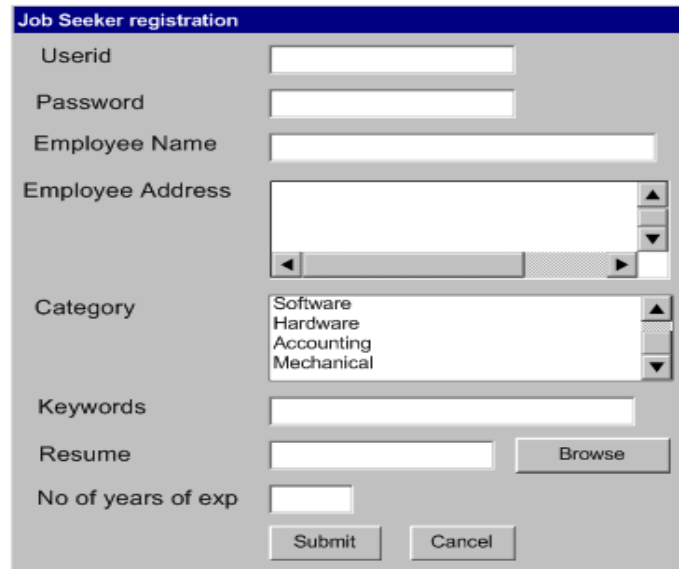

Figure 19.2 : - Job login screen

Above is how the login screen will look like. Any user who enters the job site will be identified by User Name. User Name can belong to a company or a job seeker. So when user validates he has to provide the information on which type he is logging in. So the drop down below will say that he is a job seeker or company.

√ Job Seeker registration module.

This module will be used by job seeker to register with min-job site to avail to the facilities of the job site.



The image shows a software window titled "Job Seeker registration". It contains several input fields and buttons. The fields are: "Userid" (text box), "Password" (text box), "Employee Name" (text box), "Employee Address" (text box with scroll bars), "Category" (list box with "Software", "Hardware", "Accounting", and "Mechanical" options), "Keywords" (text box), "Resume" (text box with a "Browse" button next to it), and "No of years of exp" (text box). At the bottom, there are "Submit" and "Cancel" buttons.

Figure 19.3 : - Job seeker registration

Above is a rough display of how the job seeker registration form will be. All the fields are compulsory. He can only attach word document no other type of document is permitted to be attached.

√ Job search module for job seekers.

This module will be used by job seekers to find current job posting and any matches with their profile.

The screenshot shows a 'Job Search' window with a search bar for 'Search by Key words' and a 'Number of years of Exp' field. Below these are 'Search', 'My Matches', and 'Cancel' buttons. A table lists job postings with columns for 'Company Name', 'Years of Exp', 'Job Title', and 'Apply'.

Company Name	Years of Exp	Job Title	Apply
Questpond.com	7	Need team lead for C# , SQL server	Apply
Delle Limited	3	Need Networking engineers with CISCO certification	Apply
Sharma pvt ltd	4	Helpers with English speaking capabilities	Apply
Koirala limited	10	Need web designers for a upcoming company. Knowledge of Flash and Dream weaver must.	Apply
Raj tech	0	Need fresher for accounting work	Already Applied

Figure 19.4 : - Job search employee

Job seeker can search jobs by key words (which is given by the company when they make job postings) and number of years of experience. There is a “my matches” button which will make auto matching using the keywords of your profile and the job. For instance you have provided in your profile keyword “java and mysql” then the application will take these keywords and try to find if there exists such matching in job keywords.

√ Employer’s registration module.

This module will be used by companies to register with the job site so that they can make job postings.

The image shows a software window titled "Employers Registration" with a blue header bar. The window contains several input fields: "EmployerUserid" (text box), "Password" (text box), "Employer Name" (text box), "Employer Address" (text box with vertical scroll arrows), "CompanyCategory" (list box with options: Software, Hardware, Accounting, Mechanical), and "Logo" (text box with a "Browse" button next to it). At the bottom of the window are "Submit" and "Cancel" buttons.

Figure 19.5 : - Employers registration module

All the fields are compulsory on the employers registration screen. Logo will be only of type GIF.

√ Employers job entry screen.

This module will be used by companies / job employers to enter job postings regarding there company.

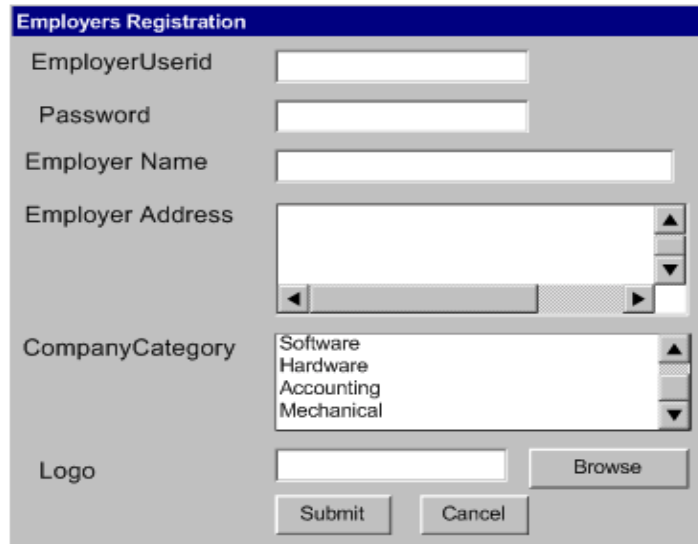
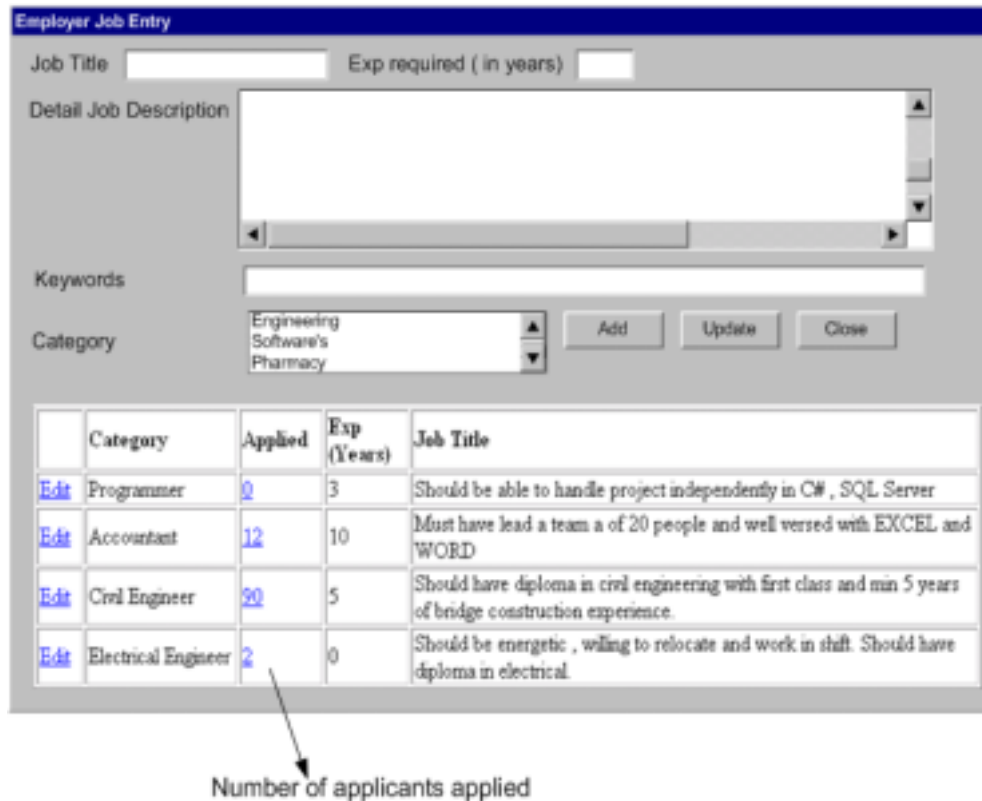

Figure 19.6 : - Employer Job Entry

Any job which needs to be posted in min-job site should have Job title, experience in number of years, detail job description, keywords and category. Employer can add, edit and close any job application posted by him. Employer can also see how many people have applied for the job. You can see in the figure with the help of an arrow showing “Number of applicants applied”. To see details of the same he can click on the link and a detail screen of the same is seen as shown below.

Employer Job Applied Status				
Job Applied for :- Need strong team lead in C# , SQL Server				
Employee Name	Years of Exp	Resume	Accept	Reject
Shivprasad Koirala	7	Download	Accept	Reject
Rajeshwar	3	Download	Accept	Reject
Mahesh	4	Download	Accept	Reject
Tapan Das	10	Download	Accept	Reject
Raju Koirala	0	Download	Accept	Reject

If already accepted or rejected then should have no enabled links

Figure 19.7 : - Detail of the job seekers applied for the job

In the above figure of job seeker detail screen he can click on download to get his resume. Employers can click on accept or reject to show further interest in the candidate. On clicking accept and reject a mail is sent to the job seeker intimating him about the response.

Chat application

This is a simple web chat application which will be used by people to talk about any job openings and interview related questions. It has only two modules the login and the chat module.

Below is the screen shot of the login module. User Name should be unique in a room. User enters a user name and clicks submit. If there is a user with a similar name “User already existing” error will be thrown and user will be redirected to the login screen.

Enter a unique user name to enter the chat room

User Name

Figure 19.8 : - Chat room login

Once user is validated he enters the chat room as shown in the below figure. To send messages in the chat room user can type in the below text box and click on the send button.

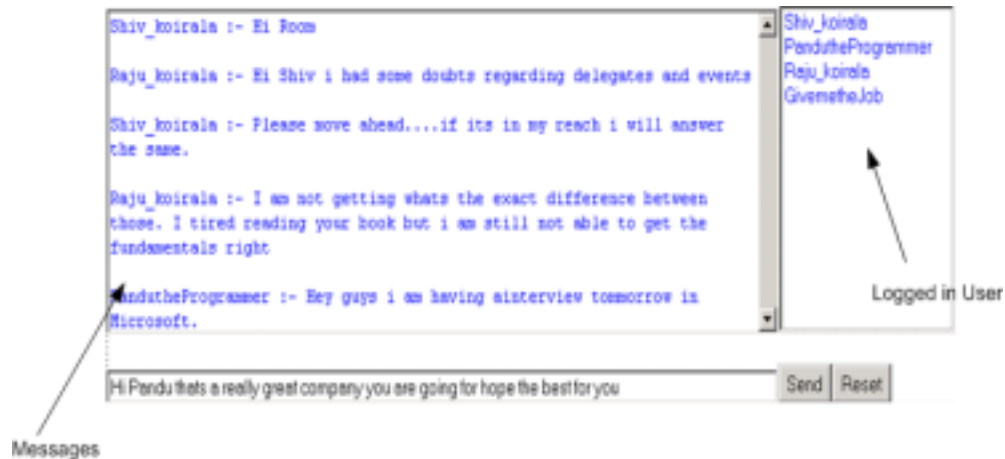

Figure 19.9 : - Chat room

Reminder Application

Reminder application is used as an alarm to remind appointments. It will be a windows based application. It will consist primarily of two modules Add reminder and Pop up reminder.

	Reminder Details	Occurrence
Edit Delete	Meeting with Project Manager	2:13 PM Monday
Edit Delete	Interview with HR	5:13 PM Tuesday
Edit Delete	Onshore client visit	5:20 AM Saturday
Edit Delete	Conference call	12:00 PM Friday

Figure 19.10 : - Add / Delete reminder

Add reminder lets you add a reminder. Reminder note, Time and weekdays are compulsory fields. Once the user adds the reminder it is seen in the grid below. User can also edit a current reminder and change its details.

Figure 19.11 : - Pop-up reminder

Reminder application will sit in the task bar. All reminders start showing up one day before the appointment. Reminders are reminded by the Pop-up reminder module which flashes in the user computer when a reminder is due. Above figure shows how the reminder will pop up. User has choice to either “Remind later” or “Dismiss” the same. If user chooses “Remind later” he will be reminded after 3 hours by default and if user chooses “Dismiss” the reminder will be purged and deleted from the reminder list.

Complete implementation of address book application

In this section we will try to complete address book application.

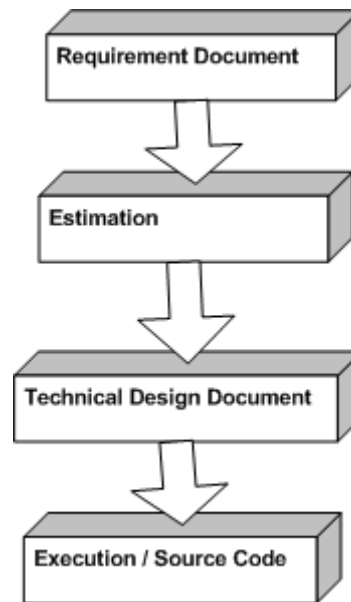

Figure 19.12 : - Different documents for Address book project

We will follow the above defined cycle. First prepare requirement document, then estimate it using function points, then prepare technical design document and finally execution and test plans.

Use Case Document for address book application

Use Case	AddressProject
Use Case Name	Maintain New Address
Description	This use case depicts the flow for adding new Address
Primary Actor	Data entry user
Trigger	User start the application
Pre-condition	Address application has already started.
Assumption	
Failed End conditions	<ol style="list-style-type: none"> 1. Name is compulsory field 2. Address is compulsory field 3. New Address is not added to database.
Action	Add New Address
Main Scenario	<ol style="list-style-type: none"> 1. User starts the address book application by double clicking on the "WindowsAddressBook" exe. 2. User is displayed with the existing addresses. 3. User enters the following information Name, Address and Phone number. 4. User then clicks on the update button. 5. If all the information filled adheres to the business logic then the new address is added to the database and displayed in the grid below. 6. Once the new address is displayed in the grid below all the textboxes are cleared and the screen waits for new address to be entered.
Action	Update Existing Address
Alternate Scenario	<ol style="list-style-type: none"> 1. Step 1 to Step 2 in executed from Add new Address. 2. User selects existing address from the grid 3. Existing address details are displayed on the screen. 4. User changes information. 5. Step 4 to Step 6 is executed from Add new Address.
Action	Delete Address
Alternate Scenario	<ol style="list-style-type: none"> 1. Step 1 to Step 3 steps are executed from "Update existing Address" action. 2. User clicks on Delete button. 3. Once the address is deleted address grid is refreshed and screen waits for new address to be entered.
Success Scenarios	<ol style="list-style-type: none"> 1. Corresponding address data changes is reflected in the grid. For instance if you add, update or delete address information same changes are reflected on the grid 2. There are no errors thrown if you click on Update and delete button.
Note and Open Issues	<ol style="list-style-type: none"> 1. Any one can add, update and delete address information from database. There is no way we can know that who had made changes to the address data. So do we need to provide a mechanism by which we can identify the user?

Figure :- 19.13 Use Case for Address book application

Estimation

The first thing after requirement gathering in the project is estimation. We will be using function point to do estimation.

Note: - For details on how to use function see Project Management chapter.

There is one table to maintain so there is only one ILF with three DET's .

Functionality	DET	RET	Value	Description
Address	3	1	7	Name,Phonenumber and Address

Figure 19.14 :- ILF values for Address book application

We have one grid to display so there will be one EQ.

Functionality	FTR	RET	Value	Description
AddressGrid Display	1	4	4	Addressgrid in the customer screen has four fields AddressID,Name,Phonenumber and Address

Figure 19.15 :- EQ for Address book application

Functionality	FTR	RET	Value	Description
AddressBook Screen	1	5	4	Name,Address, PhoneNumber,Add and Cancel

Figure 19.16 :- EI for Addressbook application

As the application is quiet simple I have kept the GSC very much simple.

GSC Attribute	Definitions	Value
Data communications:	How many communication facilities are there to aid in the transfer or exchange of information with the application or system?	1
Distributed data processing	How are distributed data and processing functions handled?	1
Performance	Did the user require response time or throughput?	1
Heavily used configuration	How heavily used is the current hardware platform where the application will be executed?	1
Transaction rate	How frequently are transactions executed; daily, weekly, monthly, etc.?	1
On-Line data entry	What percentage of the information is entered On-Line?	1
End-user efficiency	Was the application designed for end-user efficiency?	1
On-Line update	How many ILF's are updated by On-Line transaction?	1
Complex processing	Does the application have extensive logical or mathematical processing?	1
Reusability	Was the application developed to meet one or many user's needs?	1
Installation ease	How difficult is conversion and installation?	1
Operational ease	How effective and/or automated are start-up, back up, and recovery procedures?	1
Multiple sites	Was the application specifically designed, developed, and supported to be installed at multiple sites for multiple organizations?	1
Facilitate change	Was the application specifically designed, developed, and supported to facilitate change?	1
GSC		0.79

Figure: 19.17 - GSC for Address book application

Below are the final estimation figures. I have assumed that a programmer can complete 1.5 per day as it is a simple database project. So total comes to 7.9 Man days approximately 8 man days.

Project Name	Address Book	
ILF	7	
EIF	0	
EO	0	
EQ	4	
EI	4	
Total Unadjusted Function Points	15	
Total GSC	0.79	
Total Adjusted Function Points	11.85	
Programmer can complete how much FP per day	1.5	
Total Man Days	7.9	
Phases	Percentage	Man Days
Requirement Gathering	20	1.58
Technical Design	20	1.58
Execution	100	7.9
Testing	5	0.395
Total Man Days		11.455
Number of Developers		2
Total Project Schedule		5.7275

Figure 19.18 : - Complete Address book in Estimation

We also need to distribute the estimation properly in phases. As said previously we will also prepare technical documentation, write uses cases, test script etc. Always remember function points, use case points or any other estimation methodology gives you size of only execution phase. None of the estimation methodologies takes in to account hardware, documentation etc. So if 7.9 man days is my total coding effort then 20 % of that will be my technical design and requirement gathering and 5 % for testing.

Note: - You can get the complete estimation of the “addressbook” in CD.

It's very much possible that the small address book application can become a huge project by itself. So below are the assumptions while estimating.

Assumption Sections

- √ Address book will not have huge traffic load. Maximum number of users at any point will not exceed 10.
- √ No backup mechanism is implemented.
- √ No Audit history is implemented.
- √ Concurrency measures are not taken care for the project.
- √ Address book will be windows based application
- √ No login screen is provided for the application.
- √ As the data is not critical no special security aspect is taken care for the application.
- √ Estimation only includes the software cost of the project any licenses or hardware has a different cost factor.

Technical Design Document

Overview

This document will decide in detail the technical specification for the address book application according to the Use case and the initial scope provided.

Architecture approach

This is a simple desktop application which will be used by limited users. We will be using three tier architecture with access database. Access database was recommended because very less data growth is expected.

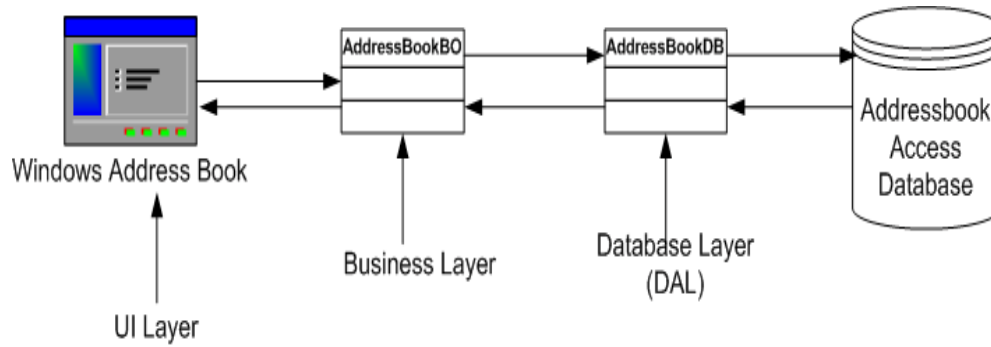

Figure 19.19 : - Architecture road map for address book application

ER Diagram

Below is the ER diagram for address database. "AddressId" is the primary key.

Field Name	Data Type
AddressId (Primary Key)	AutoNumber
Name	Text
Address	Memo
PhoneNumber	Text

Figure 19.20 :- ER Diagrams

Database Layer

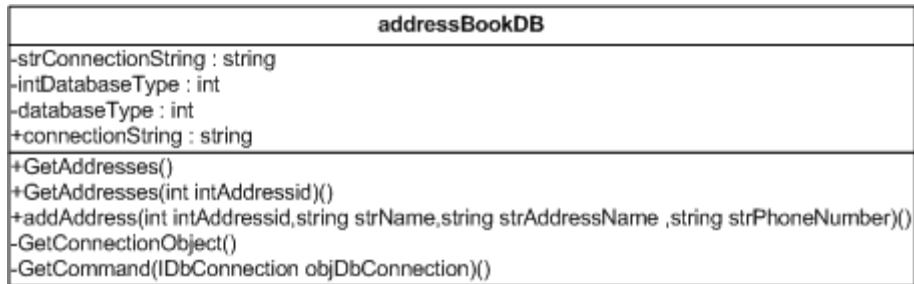

Figure 19.21 : - Database access layer diagram

Pseudo Code explanation:-

“addressBookDB” constructor

Connection string and Database type is initialized in the constructor of addressBookDB class. Both the values will be stored in “App.config” file in “appSettings” section with “ConnectionString” and “DatabaseType” key. given below is how the configuration file section will look like

```
<appSettings>  
  <add key="ConnectionString" value="here goes the connection string"/>  
  <add key="DatabaseType" value="1"/>  
</appSettings>
```

Database type will be any of the following type :-

- √ Access intDatabaseType = 1
- √ SQL Server intDatabaseType = 2
- √ Oracle intDatabaseType = 3

Pseudo-code for the constructor will be as below:-

```
public addressBookDB()  
{
```

```

// create the appsettingReader object
AppSettingsReader objAppsettingreader = new AppSettingsReader();
// Get the Connectionstring using the "ConnectionString" key
strConnectionString =objAppsettingreader.GetValue("ConnectionString");
// Get the DatabaseType using the "DatabaseType" key.
intDatabaseType = objAppsettingreader.GetValue("DatabaseType");
}

```

"GetConnectionObject" function

This function returns connection object with IDbConnection interface. This function will use connection string loaded in the "strConnectionString" property. It will do the following things:-

- √ If there is no "databasetype" specified it will raise illegal provider error.
- √ Depending on databasetype it will create the connection object. For first phase we will be only providing service to access database. So the "OleDbConnection" class object will created and assigned to the interface IDbConnection.

Note: - "IDbConnection" interface is used as we need to keep every thing generalized so that we can support multiple database types like Access, SQL Server etc. Below is the pseudo-code for the same.

```

public IDbConnection GetConnectionObject()
{
    IDbConnection objConnection = null;
    if (intDatabaseType==0)
    {
        Throwexception that illegal database provider;
    }
    // If its access then use the OleDbConnection class to create object.

```

```
// Other database like oracle and sql server will be considered for the second phase
if (intDatabaseType == 1)
{objConnection = new OleDbConnection();}
// set the connection string
objConnection.ConnectionString = strConnectionString;
return objConnection;}
```

GetCommand Function

This function will return a command object interface depending on the connection object passed. This function also returns “IDBCommand” so that we can operate with generalized command object for all database types (like Access, SQL Server etc).

```
public IDbCommand GetCommand(IDbConnection objDbConnection)
{
IDbCommand objCommand = objDbConnection.CreateCommand();
return objCommand;
}
```

GetAddresses Function

This function will return addresses from address database as “IDataReader” interface, which the clients can loop and use the same. Below is the pseudo-code for “GetAddresses” function:-

```
Public function IDataReader GetAddresses()
{
// Get the connection object using GetConnectionObject() function
objConnection = GetConnectionObject();
// open the connection object
```

```

objConnection.Open();
// Using the GetCommand function and objConnection get the command object
objCommand = GetCommand(objConnection);
// current this DAL component will only support simple SQL
// and not Stored procedures
objCommand.CommandType = CommandType.Text;
// We need all the records so us the Select * from SQL
objCommand.CommandText = "Select * from Address";
// finally execute the reader
objDataReader = objCommand.ExecuteReader();
// and then return the reader to the function
Return objDataReader;
}

```

GetAddresses (int intAddressid)

This is an over loaded function for “GetAddresses” which takes addressid as input. There is no difference from the previous function but SQL statement will change.

```

Public function IDataReader GetAddresses(int intAddressid)
{
// Get the connection object using GetConnectionObject() function
objConnection = GetConnectionObject();
// open the connection object
objConnection.Open();
// Using the GetCommand function and objConnection get the command object
objCommand = GetCommand(objConnection);
// current this DAL component will only support simple SQL

```

```
// and not Stored procedures
objCommand.CommandType = CommandType.Text;
// We need to select only one address with the specific addressid
objCommand.CommandText = "Select * from Address where addressid=" +
intAddressid;
// finally execute the reader
objDataReader = objCommand.ExecuteReader();
// and then return the reader to the function
Return objDataReader;
}
```

deleteAddress(int intAddressid)

This function delete the specific address record specified

```
public void deleteAddress(int intAddressid)
{
// First get the connection
objConnection = GetConnectionObject();
// open the connection
objConnection.Open();
// get the command object using this connection object
objCommand = GetCommand(objConnection);
// current this DAL component will only support simple SQL
// and not Stored procedures
objCommand.CommandType = CommandType.Text;
// check first if there is any addressid passed
if (intAddressid != 0)
```

```
{  
    // then delete the addressid from the address table  
    objCommand.CommandText = "delete from Address where addressid=" +  
    intAddressid.ToString();  
}  
    // execute the command  
    objCommand.ExecuteNonQuery();  
    // close the objec  
    objCommand.Connection.Close();  
}
```

addAddress

This method add and updates address records to the address table. The dotted lines are the same code as defined for the previous “Getaddresses” and “deleteaddress” sub routines. Dotted lines will have the same code

- √ Get the connection object
- √ Get the command object.
- √ Set the commandtext
- √ And finally execute the command object.

```
    Public void addAddress(int intAddressid,string strName,string strAddressName,string  
    strPhoneNumber)  
    {  
        ...  
        ...  
        ...  
        ...  
        if (intAddressid==0)
```

```
{  
  objCommand.CommandText = "insert into Address(Name, Address, Phonenumber)  
  values('" + strName + "', '" + strAddressName + "', '" + strPhoneNumber + "')" ;  
}  
  
else  
  
{objCommand.CommandText = "update Address set name='" + strName + "',  
Address='" + strAddressName + "',phonenumber='" + strPhoneNumber + "' where  
addressid=" + intAddressid.ToString();}  
  
...  
Objcommand.executenonquery();}
```

Business Layer

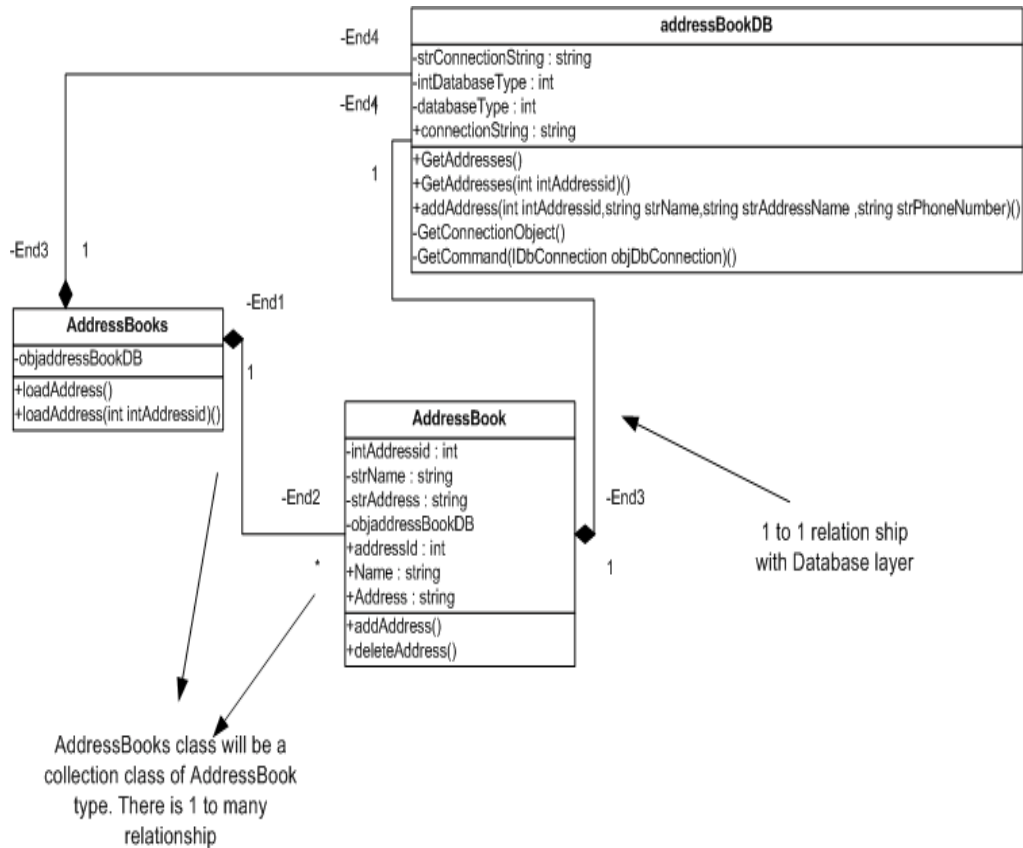

Figure 19.22: - Business object diagram

Above is the business object diagram for the address application. There are two main business objects:-

AddressBook

This class will have the validations and two basic operational functionalities adding new addresses and delete addresses. “AddressBook” class represents a single entity class.

All the business validations will be written in the set property of the class. For instance for the name property you can see that if there is no name provided it will throw error to the client.

```
Public string Name
{Set
{
// if the strName is not provided then throw a exception
    If value.length == 0
    {
        Throw new exception("Name is a compulsory field");
    }
    // if all the validations are ok then set the private value
    strName = value;}
Get
{return strName;}}
```

Same type of business validation will follow for address property.

addAddress()

This method will call the "addAddress" method of the database class "addressBookDB" and add new address record in the database.

Pseudo-code for calling the database object will be something as given below.

```
addressBookDB.addAddress (intAddressid, strName, strAddress, strPhoneNumber)
```

Also note that the private variables passed to the address database objects.

deleteAddress()

This method will call the “deleteAddress” method of the “addressBookDB” class and delete a particular address from the address database.

Pseudo-code for calling the database object will be something as below.

```
addressBookDB.deleteAddress(intAddressid);
```

AddressBooks (inherits from Collectionbase)

This class will be having collection of “AddressBook” type objects and it inherits from the System.collections. Collectionbase class. “AddressBooks” represents a collection. It has the following methods and properties:-

LoadAddress

“Loadaddress” method loads the address in to collection base. Below is the pseudo-code for the same.

```
public void loadAddress()  
{  
// before we load all the address clear the list collection  
List.Clear();  
// call the addressbookdb and and the get the address datareader  
objDatareader = objaddressBookDB.GetAddresses();  
// loop through the datareader and load the  
// collection of addressbooks  
while (objDatareader.Read())  
{  
AddressBook objAddressBook ;  
objAddressBook = new AddressBook();  
objAddressBook.addressId = objDatareader["Addressid"];
```

```
objAddressBook.Address = objDatareader["Address"].ToString();  
objAddressBook.Name = objDatareader["Name"].ToString();  
objAddressBook.PhoneNumber = objDatareader["PhoneNumber"].ToString();  
// after the values are set add it to the list collection  
List.Add(objAddressBook);  
}  
// finally close the object  
objDatareader.Close();  
}
```

LoadAddress(int intAddressid)

This is a overloaded method it will have the same logic as defined previously for “loadAddress” method without parameters. Only that it will call

```
objaddressBookDB.GetAddresses(intAddressid);
```

Presentation Layer

FrmAddressBook.cs

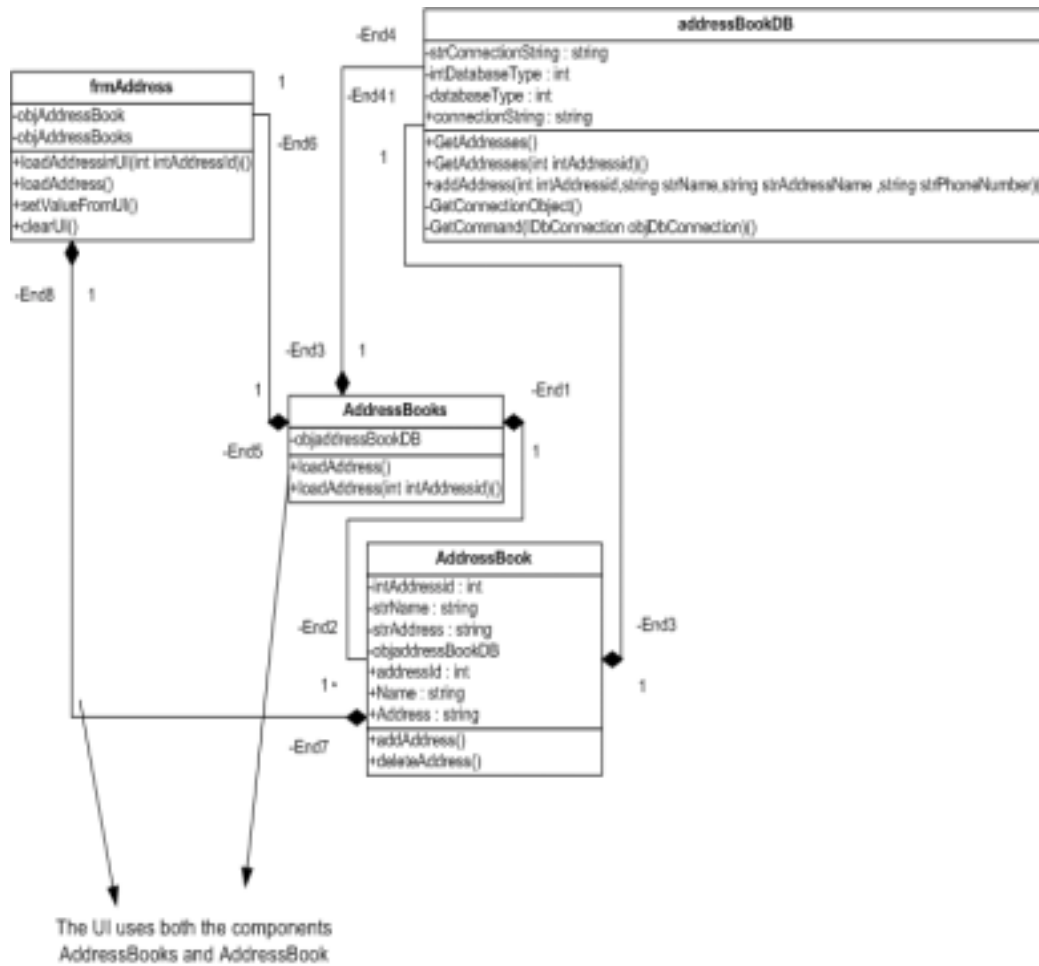

Figure 19.23 : - UI component Diagram

Presentation layer define the way “addressbook” and “addressbooks” object will flow and interact.

Following are the various methods and properties in the presentation layer:-

AddressBook and AddressBooks object will define a private variable in the presentation layer.

```
private AddressBook objAddressBook = new AddressBook();  
private AddressBooks objAddressBooks = new AddressBooks();
```

GUI components

GUI Object	Type	Description
txtName	TextB ox	Textbox for taking Name which is given by user.
txtAddress,	TextB ox	Textbox for taking address data which is given by user.
txtPhoneNumber	TextB ox	Will be used to take data for Phone number.
lblName , lblAddress and lblPhoneNumber	Label	Label to display the caption for the three entities.
cmdUpdate, cmdCancel and cmdDelete	Button	Command buttons for “Adding” , “deleting” address data. Cancel will clear what ever is typed by user.
dgAddresses	DataGrid	Grid to display address data.

Figure 19.24 :- GUI Component list

setValueFromUI

This will take the value from the UI components and set it to the address object. Pseudo-code is as shown below:-

```
private void setValueFromUI()  
{  
objAddressBook.Name = txtName.Text;
```

```
objAddressBook.PhoneNumber = txtPhoneNumber.Text;  
objAddressBook.Address = txtAddress.Text;  
}
```

ClearUI

This sub routine clears all the user interface values.

```
private void clearUI()  
{  
txtName.Text = "";  
txtPhoneNumber.Text = "";  
txtAddress.Text = "";  
}
```

LoadAddress

This subroutine will bind the address collection object that is objAddressBooks to the datagrid.

```
private void loadAddress()  
{// call the load method of the addressbooks object  
objAddressBooks.loadAddress();  
// clear all the previous records in the grid  
dgAddresses.DataSource = null;  
//rebind the fresh new data in t he addressbooks collection  
dgAddresses.DataSource = objAddressBooks;  
// refresh the grid  
dgAddresses.refresh();  
}
```

LoadAddressinUI

“LoadAddressinUI” does the exact opposite of what “SetValueFromUI” does.

```
public void loadAddressinUI(int intAddressId)
{
// Load the addressbooks object with the addressid
objAddressBooks.loadAddress(intAddressId);
// check if there are any address object loaded
if (objAddressBooks.Count > 0)
{
// if yes then set the current addressbook object to the first object of the
// addressbooks collection object
objAddressBook = objAddressBooks[0];
}
// finally load all the object value in to the address book UI
txtName.Text = objAddressBook.Name;
txtAddress.Text = objAddressBook.Address;
txtPhoneNumber.Text = objAddressBook.PhoneNumber;}
```

Method call flow for address book



Figure 19.25 : - Method flow in UI

Above shows how the methods will interact among themselves to accomplish the task.

Test plans

Add new Address with Name as nothing

Steps for the test:

- √ Start the Address book application
- √ Enter the following data

Field	Value to be entered
Name	
Phone Number	8978897
Address	b-201 , OASIS , Mulund

- √ Press Update button
- √ System should pop up with error message “Name is Compulsory field”
- √ Enter proper Name data.
- √ Press update button
- √ System should save the information and display the newly entered data in the grid below.

Add new Address with Address as nothing

Steps for the test:

- √ Start the Address book application
- √ Enter the following data

Field	Value to be entered
Name	<u>Shivprasad Koirala</u>
Phone Number	2137891273
Address	

- √ Press Update button

-
- √ System should pop up with error message “Address is Compulsory field”
 - √ Enter proper Name data.
 - √ Press update button
 - √ System should save the information and display the newly entered data in the grid below.

Update Address

Steps for the test:

- √ Start the Address book application
- √ Select one of the addresses from the address data grid. Address details will be displayed on the textboxes above.
- √ Change some information in all the three fields.
- √ Press Update button
- √ System should save the changed information and display the newly entered data in the grid below.

Cancel Address

Steps for the test:

- √ Start the Address book application
- √ Enter the following data

Field	Value to be entered
Name	Shivprasad Koirala
Phone Number	2137891273
Address	

- √ Press Cancel button

√ System should clear all the three textboxes.

Delete existing Address data

Steps for the test:

- √ Start the Address book application
- √ Select one of the addresses from the address data grid. Address details will be displayed on the textboxes above.
- √ Press Delete button
- √ System should delete the selected address and grid below is refreshed and the currently deleted address is not displayed in the grid.

Source code

You can get the source code from the CD. I have tried to comment as much as possible but if you do not get some logic mail me at shiv_koirala@yahoo.com. Below are the snapshot of all the documents which are provided in the CD. As this is a sample project the documents are small in size and not that complicated. But when it comes to huge projects there are more documents than what I have created. But these are the basic documents which you should have.



Figure 19.26 :- Requirement Gathering Document Snapshot.



Figure 19.27 : - Technical Specification Document Snapshot



Address Book Application Version 1.0

Test Cases Document

Document History	2
Outstanding Issues	2
Test Plans	2
Add new Address with Name as nothing	2
Add new Address with Address as nothing	3
Update Address	3
Cancel Address	3
Delete existing Address data	4

Figure 19.28 : - Test case document snapshot

When you run the application you can get the following error. This happens because the connection string is not pointing to proper path where MDB file exists.

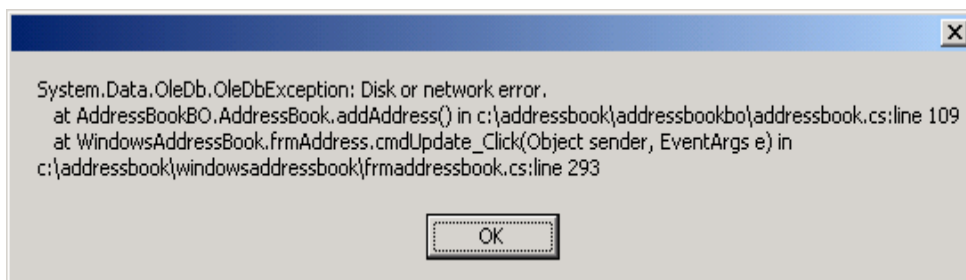

Figure 19.29 : - Error while running address book application

So click on the config file “WindowsAddressBook.exe.config” which is present in the “Debug” folder and open the same in notepad.

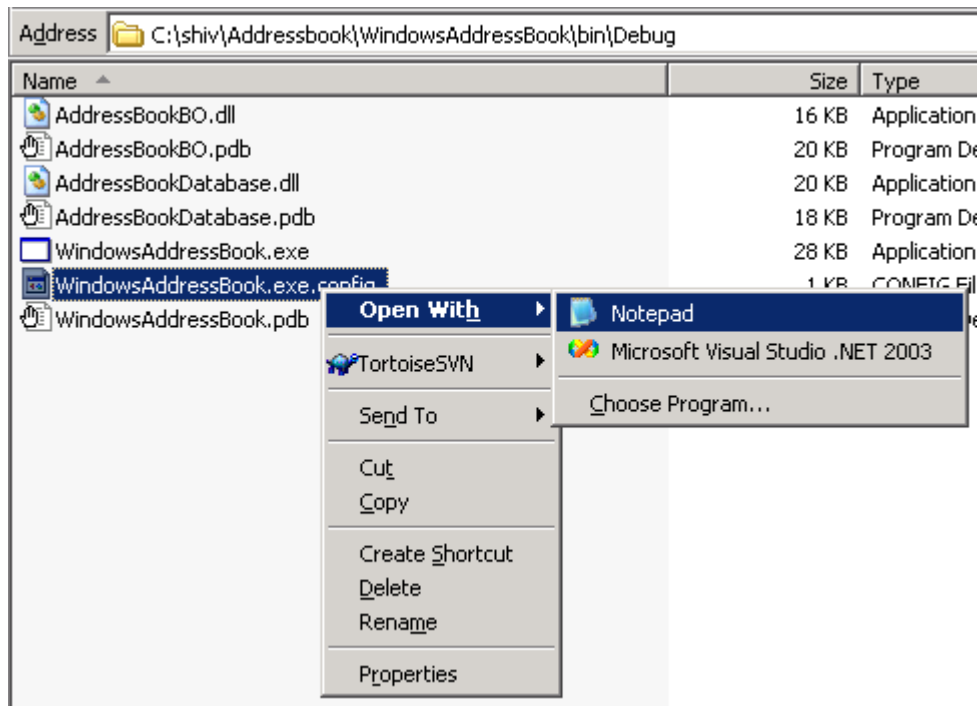

Figure 19.30 : - Edit “WindowsAddressBook.exe.config”

After you edit the config file in notepad change the “Datasource” property in “ConnectionString” to the path where the database file .MDB is located.

20. Test Yourself

Q1. “Crushader” company wants to revamp his website. One of the important changes “Crushader” want is to display Ad banners. As a developer you want to initialize the banner image paths when the first user accesses the application. So what will you do?

1. Add code in application_onstart event of global.asax file.
2. Add code in application_begin request event of global.asax file.
3. Add code to session_onstart event of global.asax.
4. Add code in page.load event handler in the startup page of the application.
5. Create a user control named “Banner.ascx” and initialize all the image paths in this ascx. Then include this banner.ascx in all the pages of the application which needs the banner displays.

Answer 1.

Q2 Which one of the following is a limitation of XML serialization?

- A. In classes that implement IEnumerable, the collection is not serialized.
- B. You cannot serialize an object's public fields.
- C. You cannot serialize DataSet objects.
- D. You cannot serialize XmlNode object.
- E. It does not serialize type information.

Answer E

XML serialization does not include type information. For example, if you have a Customer object that exists in the Library namespace, there is no guarantee that it will be deserialized into an object of the same type.

Q3 Which one of the following occurs when a struct type is cast to an interface that it implements?

-
- A. The original value type variable is destroyed.
 - B. A trappable `InvalidCastException` runtime error occurs.
 - C. A compiler error occurs; struct types cannot implement an interface.
 - D. The struct type is boxed and a new reference type created.
 - E. The original value type is cloned using the `ValueType` class' implementation of `IClonable`.
- D But yes you can implement interface in structures. As interface can be only reference types so it will boxed.

Q4

```
internal class Piston {}
internal class Engine
{
    private Piston[] myPistons = new Piston[4];
    public bool Ignition() {
        //some code
    }
}
public class Car
{
    private Engine myEngine = new Engine();
    public void Start()
    {
        //put in keys etc..
        if (myEngine.Ignition()) {
            //some more code
        }
    }
}
```

```
}  
}  
}
```

What concept does the above sample code demonstrate?

- A. Delegation
 - B. Composition
 - C. Polymorphism
 - D. Combination
 - E. Inheritance
- B

Q5. As a developer you are displaying product data from SQL Server. Product table has Productid and ProductName. You write ADO.NET code that uses a SqlDataAdapter object and a SqlCommand object to retrieve the product data from the database by calling a stored procedure. You set the CommandType property of the SqlCommand object to CommandType.StoredProcedure. You set the CommandText property of the object to procProductList. Your code successfully fills a DataTable object with a list of products that is sorted by ProductID in descending order.

You want the data to be displayed in reverse alphabetic order by ProductName.

What should you do?

- A. Set the command text to "SELECT * FROM procProductList ORDER BY ProductName DESC;" then bind the DataGrid control to the DataTable object.
- B. Create a new DataView object based on the DataTable object.
- C. Set the Sort Property of the DataView object to "ProductName DESC".
- D. Bind the DataGrid control to the DataView object.
- E. Set the AllowSorting property of the DataGrid control to True.

F. Set the SortExpression property of the DataGridColumn that displays ProductName to bind the DataGrid control to the DataTable object.

G. Set the DisplayExpression property of the DataTable object to "ORDER BY ProductName DESC". Bind the DataGrid control to the DataTable object.

Answer A

Q6. What is the fastest way to concat strings in ASP.NET ? What should you do?

A. Write code that uses the Append method of the StringBuilder object.

B. Write code that uses the Substring method of the String object.

C. Write code that uses the Concat method of the String object.

D. Write code that uses the plus-sign (+) operator to concatenate the strings.

Answer: A

Q7. "Virtual Software public limited" wants to connect to SQL Server 6.5 using ASP.NET ?

A. Use a SqlConnection object to connect to the database, and use a SqlCommand object to run a stored procedure that returns the data.

B. Use an OleDbConnection object to connect to the database, and use an OleDbCommand object to run a stored procedure that returns the data.

C. Configure SQL Server to support HTTP access, and create an XML template to run a stored procedure that returns the data in XML format.

D. Use COM interop to create an ADODB.Connection object, and use an ADODB.Command object to run a SQL statement that returns the data.

Answer B

You can not use SQL Server .NET Data Provider for SQL Server 6.5. Its only for SQL 7.0 and later

Q8. You want to only get changed data in a dataset which of the below is the best way ?

- A. `productInfo.GetChanges(DataRowState.Detached);`
- B. `productChanges = productInfo.GetChanges();`
- C. `productChanges.Merge(productInfo, true);`
- D. `productChanges.Merge(productInfo, false);`

Answer: B

Q9. Which of the following does the actual .NET code execute ?

- A MSIL
- B CLS
- C CLR
- D C#
- E CTS

Ans :- C

Q10. Hiding implementation and exposing the interface in OOP's is called as :-

- A) Polymorphism
- B) Encapsulation
- C) Overloading
- D) Static

Ans :- B

Q11. Garbage collector runs ?

- 1) When Application is running for more than 30 minutes.
- 2) Every 1/4th Milli Second.

3) When application is running low of memory.

4) Its very random and takes random time from the CPU clock.

Ans :- 3

Q12. Which line is invalid in the code below ?

1. interface Test2

2. {

3. int i;

4. void Method2A(int);

5. string Method2B ();

6. }

A. Line 3

B. Line 4

C. Line 5

Answer :- A

Q13. You want to debug a Web-based ASP.NET application. But for some cause debugging information is not shown. What could be missing?

A. <%@ Page Debug="true" %>

B. <%@ Application Debug="true" %>

C. <%@ Page Trace="true" %>

D. <%@ Application Trace="true" %>

Answer :- A.

Q14. What property is used on the DataTable to indicate conflicts after update method is called?

- A. HasErrorConflict
- B. HasError
- C. HasCollision
- D. HasDataError

Answer :- A

Q15. What is a DiffGram?

- A. XML file containing both the original and current values for the data.
- B. XML file containing the difference between original and current data.
- C. DataSet loaded with two XML files, resulting in the difference being current.
- D. DataSet loaded with an XML file and the original values from the data source.

Answer :- A

What ASP.NET object encapsulates the state of the client and the browser?

- A. Application object.
- B. Session object.
- C. Response object.
- D. Request object.
- E. Server object

Answer :- B

Q16. What method(s) must be used with the Application object to ensure that only one process accesses a variable at a time?

- A. Synchronize()
- B. Lock() and UnLock()

C. ThreadLock

D. Synchronize.

Answer :- B

Q17. Which object can help you maintain data across users?

A. The Session object.

B. The Application object.

C. The Response object.

D. The Request object.

E. The Server object

Answer :- B

Q18. What must be done before you can consume a web service?

A. Build a proxy library by using the TblImp.exe utility.

B. Build a proxy library by using the Disc.exe utility.

C. Build a proxy library by using the csc.exe utility.

D. Build a proxy library by using the wsdl.exe utility

Answer :- D

Q19. What control is used to validate that two fields are equal?

A. RequiredFieldValidator

B. RegularExpressionValidator

C. CompareValidator

D. The equals() method of the field.

Answer :- C

Q20. Why should you close all database objects and set them to NULL before leaving the method where the objects were created?

- A. To ensure that the object's destructors are called.
- B. To ensure that the connection to the database is closed as soon as possible.
- C. To ensure that the objects can be reused.
- D. Good coding practice.

Answer :- B

Q21. You are developing a web application that is retrieving historical library information from a database server and displays it to the users of your application. What cache strategy will give you the best performance?

- A. Use the output cache.
- B. Use the cache object.
- C. Use the ASP.NET central cache.
- D. Use the client cache

Answer :- B

Q22. Which tool can you use to precompile a Windows application?

- A. msconfig.msc
- B. ngen.exe
- C. caspol.exe

Answer :- B

Q23. Which method of the ServiceController class will allow you to send a command to the service?

-
- A. Stop()
 - B. Start()
 - C. Pause()
 - D. ExecuteCommand()

Answer :- D

Q24. .NET remote server object must implement?

- A. IUnknown
- B. IMarshalByValue
- C. IMarshalByRef
- D. ISingleCall
- E. ISerializable

Answer :- E

Q25. You are in charge of creating a remote object that will return database records to the caller of the method. You want to keep track of the number of requests. Which activation mode would you use?

- A. SingleCall
- B. Singleton
- C. Client-activated
- D. Server-activated

Answer :- B

Q26. You want to ensure that your web method uses the cache for results, so you change the web method attribute to [WebMethod(BufferResponse = true)]. When you investigate, you find that your web method still is not using the cache. What is the most effective way of ensuring that your web method uses the cache?

- A. Add CacheTime=300 to the WebMethod attribute.
- B. Add Cache=true to the WebMethod attribute.
- C. Add EnableCache=true to the WebMethod attribute.
- D. Add CacheDuration=300 as a parameter to the WebMethod attribute.

Answer :- D

Q27. What namespace must be used in order to use the DOM for XML support?

- A. System.Data.Xml
- B. System.Xml
- C. System.Xml.DOM
- D. System.DOM

Answer :- B

Q28. You need to encrypt the SOAP header. What is the correct method to use?

- A. Inherit the web service class from the SoapHeaderEncrypt class.
- B. Custom SOAP headers.
- C. SOAP header extensions.
- D. Enable SSL for the XML web service and configure it to encrypt the headers.

Answer :- C

21. Free exams

√ (Thanks to www.measureup.com click on demo link its decent.)

<http://cybermediadice.measureup.com/cart/displayproducts.asp>

22. Pending Topics

I have made an attempt to cover most of the topics. But still there are lot of important topics pending which can turn the tables around. As this been a interview book its also important to notify the readers what it did not cover and are important for .NET Interviews. I had promised in my last edition to cover the below questions but my bandwidth did not support it as VISTA and AJAX was my priority. I will surely try to cover the * in my fourth edition.

- √ Crystal reports. As reporting services has taken over the full market of reports I have covered a complete chapter in SQL Server Interview question book. But still there are organization who ask crystal reports even today. So just in case brush you skills regarding the same.
- √ * Setup and Packaging.
- √ * VSTS
- √ Biztalk Server.
- √ Sharepoint.
- √ Commerce Server.
- √ *Debugging

what is the difference between debug and trace ?.

what does assert statement do ?.

Which are the five tracing levels in System.Diagnostics.TraceSwitcher

Can you explain TextWriterTraceListener?

How do you debug an ASP.NET Web application?

If you feel that something very important and basic not covered in the book mail at shiv_koirala@yahoo.com. I will make a attempt to close it in the third edition.